

# SDV3 Series Servo System General Purpose





## Company Profile

Savch Electric Co., Ltd was set up in Quanzhou, Fujian province in 2001 and established a research and development center in Shanghai. It is one of the first few companies to develop and produce motor drives in China. In 2005, it became China's top ten inverter brands. The company relies on a strong R & D team and world-class power electronics production and quality control system (OEM for top international brand) to provide customers with high-performance servo drives, inverters, computer controllers and other industrial control products.

The company focuses on the frontier technology fields of "industrial intelligence, energy saving, green energy", and adheres to the core goal of "creating value for customers", and establishes a technical R&D team that highly conforms to customer industry characteristics and highly integrated mechatronics and provide more efficient and resource-efficient system solutions for various industries customers. For the pass years, the company has established a global equal and close cooperation agent system, and customer service system with user satisfaction as an indicator, widely used in ceramics, packaging, textile, dyeing and finishing, engineering upgrading, lifting, road, CNC machine tools, glass, mining, petroleum, shipbuilding, military and even farming and animal husbandry and other equipment fields.



The SDV3 series is a cost-effective servo system (motor & drive), which can be widely used in a large industry, such as laser marking machine joint robot, linear mechanical hands, wood machinery, glass machinery, injection molding machinery, welding and cutting equipment, ceramic equipment, textile equipment, testing equipment, cable equipment, lithium battery equipment, electronic manufacturing equipment, milling machines, grinding machines, CNC lathes, food production lines, packaging production line, engraving and milling machine, engraving machine, high light machine, around line machine, warp knitting machine, labeling machine, veneer machines etc.

## High Performance

- Response frequency up to 1.2kHz
- Support 17 bit/20 bit encoder
- Low cogging torque
- 3 times overload ability

## Intelligent

- Identification of load inertia
- Real-time automatic gain adjustment
- Automatic/Manual notch filter
- Automatic/Manual vibration suppression control

## Practical

- Highly flexible script function
- Input/output signal assigned
- Internal position programming mode
- Interrupt position control
- Support CANopen, EtherCAT to realize multi-axis high response synchronization control
- Friction torque compensation
- Gain switch
- Torque limit change
- Motor and drive miniaturization

- This contents of catalog is only for selecting products models and types , when using a product, read the users' manual beforehand to use the product correctly.
- Products introduced in this catalog haven't been designed or manufactured for such applications in a system or equipment that will affect human bodies or lives clients, who want to use the products introduced in this catalog for special systems or device such as for military, aerospace and medical use, and traffic control are requested to consult SAVCH's Sales Center.
- Clients are requested to prepare safety measures when they apply the products introduced in this catalog to such systems or facilities that will affect human lives or cause severe damage to property if the products become faulty.



## Notch Filter (Auto-Notch Filter)

- When the mechanical resonance is detected, the notch filter will be automatically set.
- When the automatic notch filter is opened, it can carry out detection operation, so it can also deal with the time variation of the resonance frequency.

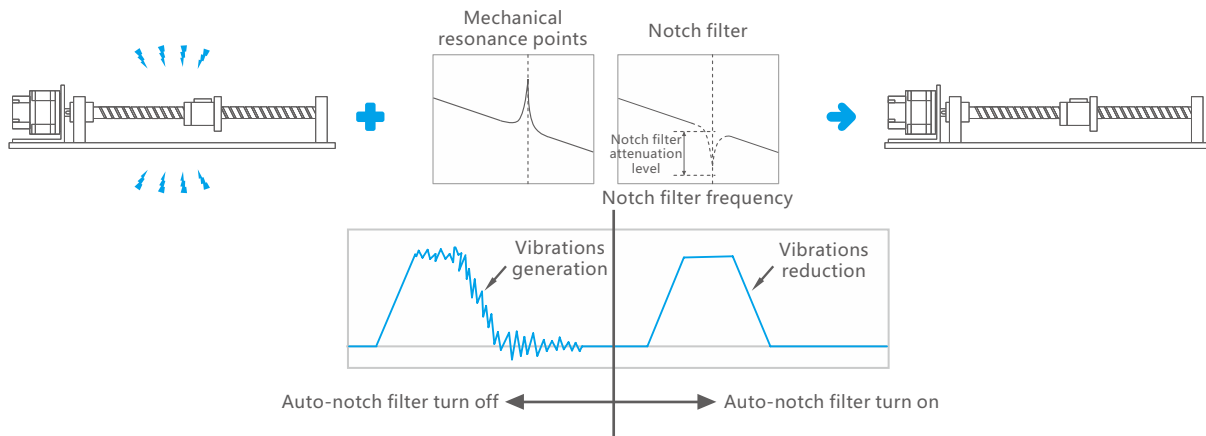

## Mechanical Vibration Suppression

- The standard is equipped with the newly designed vibration suppression control function, which can maximize the suppression of the vibration of machinery.
- It can solve the problem of vibration of the low rigidity machine in the front of the robot arm, and realize the stable operation of the machine.

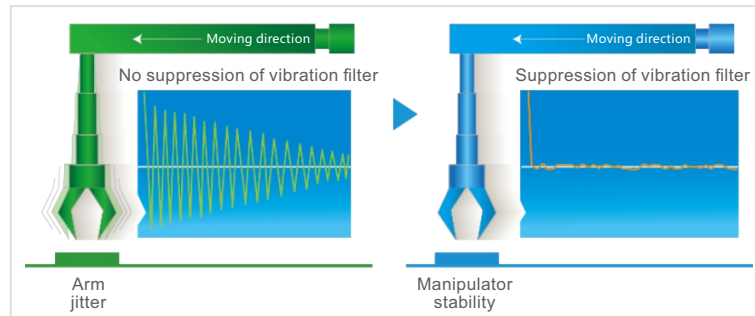

## New Auto-Tuning Function

- Newly designed auto-tuning function greatly improves the SDV3 auto-adaptive performance. Even the machine is with low rigidity, it can also carry on the most appropriate adjustment.

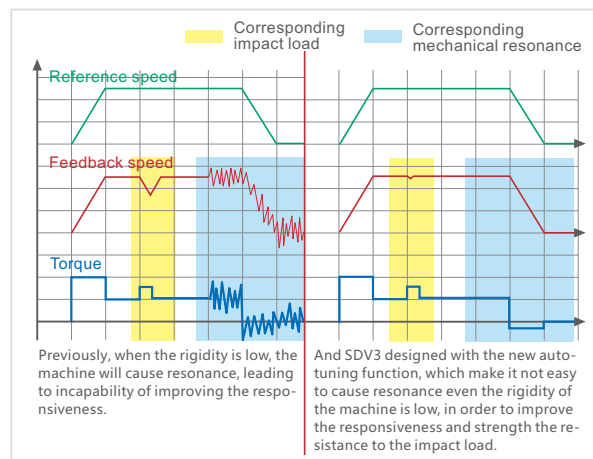

## Script Function

- The built-in script function can replace the PLC and other upper computers to realize the logic programming function, which greatly improves the flexibility of the servo application.
- The script is programmed by the supporting host computer software, and the instructions are simple and easy to use.

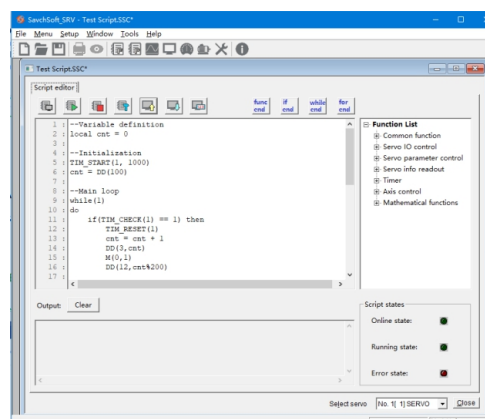

## System Structure Diagram

- SDV3-2S0.4G~2S0.75G

### 【 No-Fuse Breaker (NFB) 】

- To prevent the large instand current received by the power-on, power-off or the short circuit and damage the drive.



### 【 Power Supply 】

- Single phase AC 200~230V



CN5  
CN4

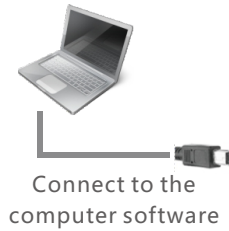

Connect to the computer software



Connect to the host controller

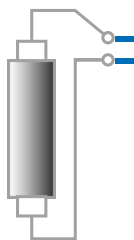

### 【 External retrogradation resistor 】

- Optional

【 Servo Motor Power Cable 】



【 Grounding terminal 】

【 SDV3 Servo Drive 】

General Encoder



【 Encoder Cable 】

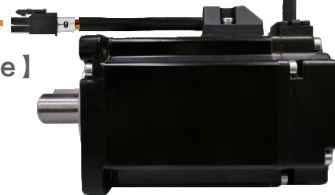

【 Servo Motor 】

### 【 Installation Notes 】

- Check the L1, L2 power and connecting wire.
- Check the servo motor output U, V, W terminal phase wires (Unable to run when the connection is wrong).
- External connected regeneration resistor is the selective spare, adopt according to the actual needs.
- CHARGE indicator is on means that the power is on. When the Power is turned off, there is still left with electric in the main-circuit, so the cable should be removed only when all the indicators are off.

- SDV3-2S1.0G~1.5G/4T0.75G~2.0G

**【 No-Fuse Breaker (NFB) 】**

- To prevent the large instand current received by the power-on, power-off or the short circuit and damage the drive.



**【 Power Supply 】**

- Single phase AC 200~230V (connect to the L1,L2)
- There phase AC 380~460V



CN5  
CN4



Connect to the computer software

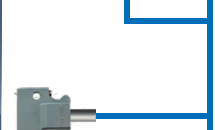

Connect to the host controller

General Encoder

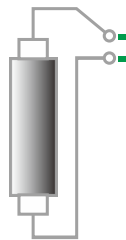

**【 External retrogradation resistor 】**

- Optional

**【 Servo Motor Power Cable 】**

**【 SDV3 Servo Drive 】**

**【 Grounding terminal 】**

**【 Encoder Cable 】**

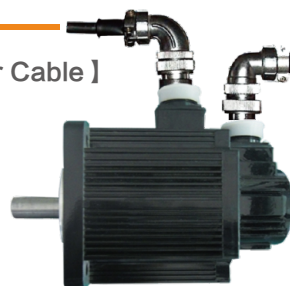

**【 Servo Motor 】**

**【 Installation Notes 】**

- Check the L1, L2, L3 power and connecting wire.
- Check the servo motor output U, V, W terminal phase wires (Unable to run when the connection is wrong).
- External connected regeneration resistor is the selective spare, adopt according to the actual needs.
- CHARGE indicator is on means that the power is on. When the Power is turned off, there is still left with electric in the main-circuit, so the cable should be removed only when all the indicators are off.

## Model Description

• Servo Motor

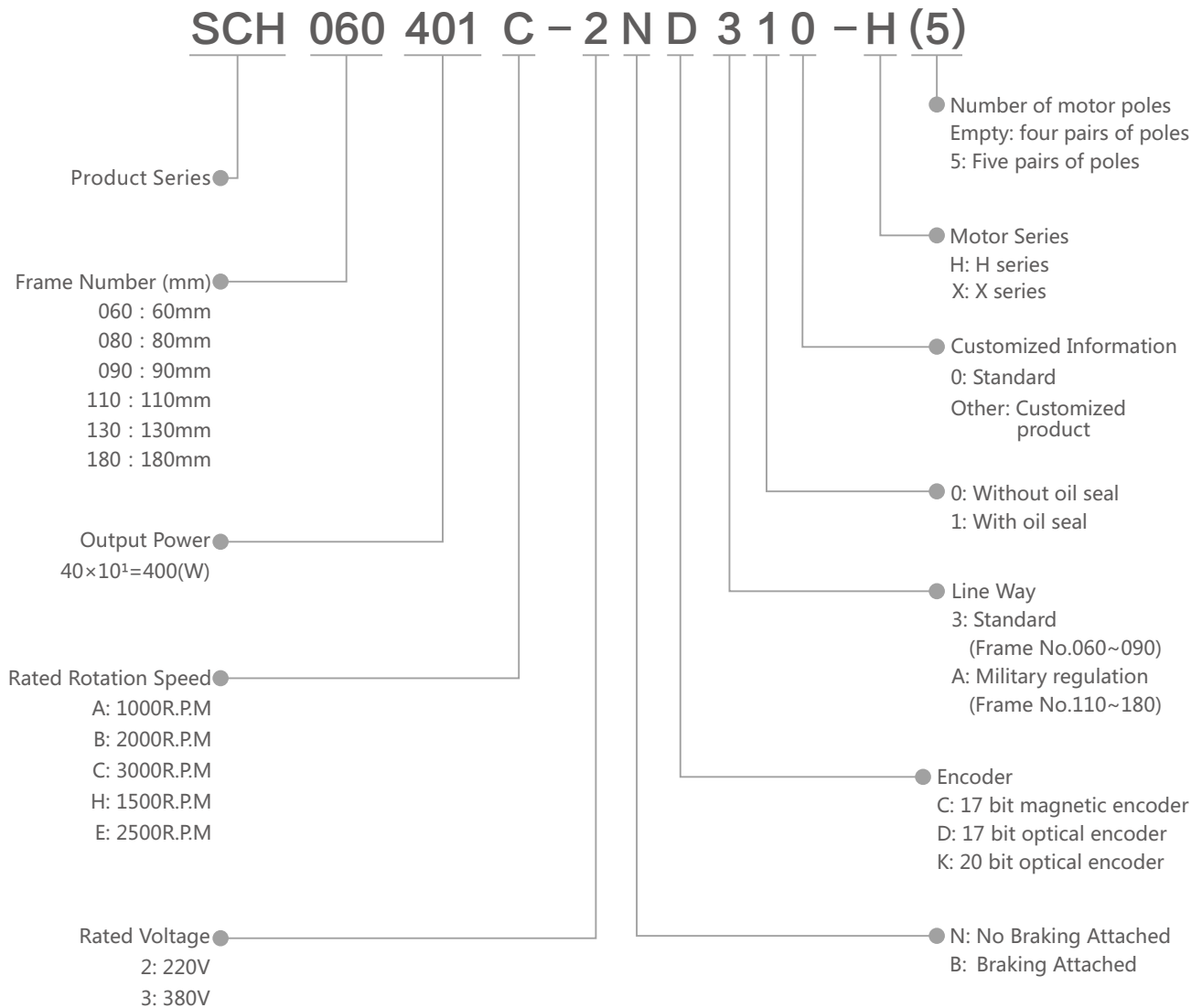

• Servo Drive

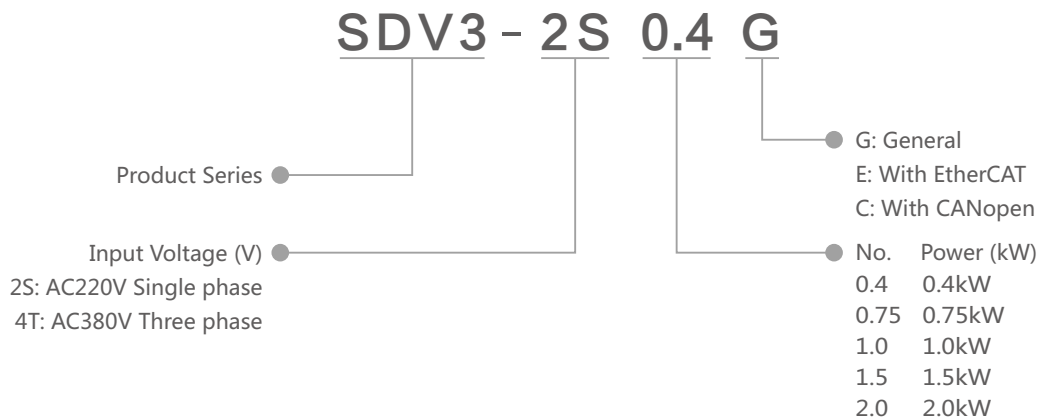

## Servo Drive Specification

### • Common Specifications

Item		Specifications
Input Power		Single phase 220V / Three phase 380V
		Voltage variation range (-15%~ +10%) 50/60Hz
Cooling Method		Fan cooling
Main Circuit Control Mode		Sinusoidal PWM drive
Feedback		17Bit INC/20Bit INC
Control Mode		①Position control ②Speed control ③ Torque control ④Position/speed mode switch ⑤Position/torque mode switch ⑥Speed/torque mode switch ⑦Positioning operation mode
Position Control	Max input pulse frequency	Line Drive input: Max 500kHz Open Collector Input: Max 200kHz
	Command pulse input mode	①Command pulse/command signal ②Forward rotating pulse and reverse rotating pulse ③A/B phase orthogonal pulse
	Command control mode	①External command pulse input control ②Internal position data control
	Electronic gear	Electronic Gear N/M times (N:1~4194304)/M:1~4194304)
	Torque limitation	Parameter control (Forward rotating and reverse rotating can be set respectively)/ External analog torque control
Speed Control	Analog command input	VCL DC0~±10V
	Speed variation rate	±1r/min or below (load range 0~100%)
	Speed range	1:5000
	Acceleration and deceleration time setting	Acceleration time and deceleration time can be set respectively, and have two groups, and can accelerate and decelerate with S curve
	Speed control method	External analog input,Parameter setting,Communication speed command, Command pulse frequency
	Torque Limitation	Parameter control (Forward rotating and reverse rotating can be set respectively)/ External analog torque control
Torque Control	Analog command input	VCL DC0~±10V
	Torque Limitation	Parameter control/External analog speed limitation
Digital Input/Output	Input	EI1~EI5 5 lines input, the function can be set freely according to the parameter
	Output	Encoder pulse outputs by frequency division, A/B/Z phase output by line drive EOUT1~EOUT3 3 lines output, the function can be set freely according to the parameter
Monitor		Feedback speed, reference speed, reference torque, motor current, feedback of current location, Location Difference, reference pulse frequency, Feedback Pulse Accumulation, Reference Pulse Accumulation, VREF input voltage, TREF input voltage, input terminal signal, output terminal signal etc
Protection (Alarm display)		Overcurrent (oc1, oc2), Over speeding (oS), Overvoltage(Hv), Memory Error (dE), Encoder Error(Ec), Overload (oL1, oL2), Main circuit under voltage (Lu), EI Repeat (ctE), Deviation overflow (oF), Servo motor drive overheat (AH) etc.
Application Environment	Site location	Indoors (Avoid direct sunlight), No corrosive gas (Avoid smoke, methane)
	Ambient Temperature	0~50°C (When the ambient temperature is higher than the required one, please introduce air circulation)
	Storage Temperature	-20°C~75°C
	Relative humidity	RH 90% lower (No condensation)
	Altitude	Lower than 1000m
	Atmospheric pressure	86~106kPa
	Vibration	≤0.5G



# Wiring Diagram

• Position Control Standard Wiring Diagram

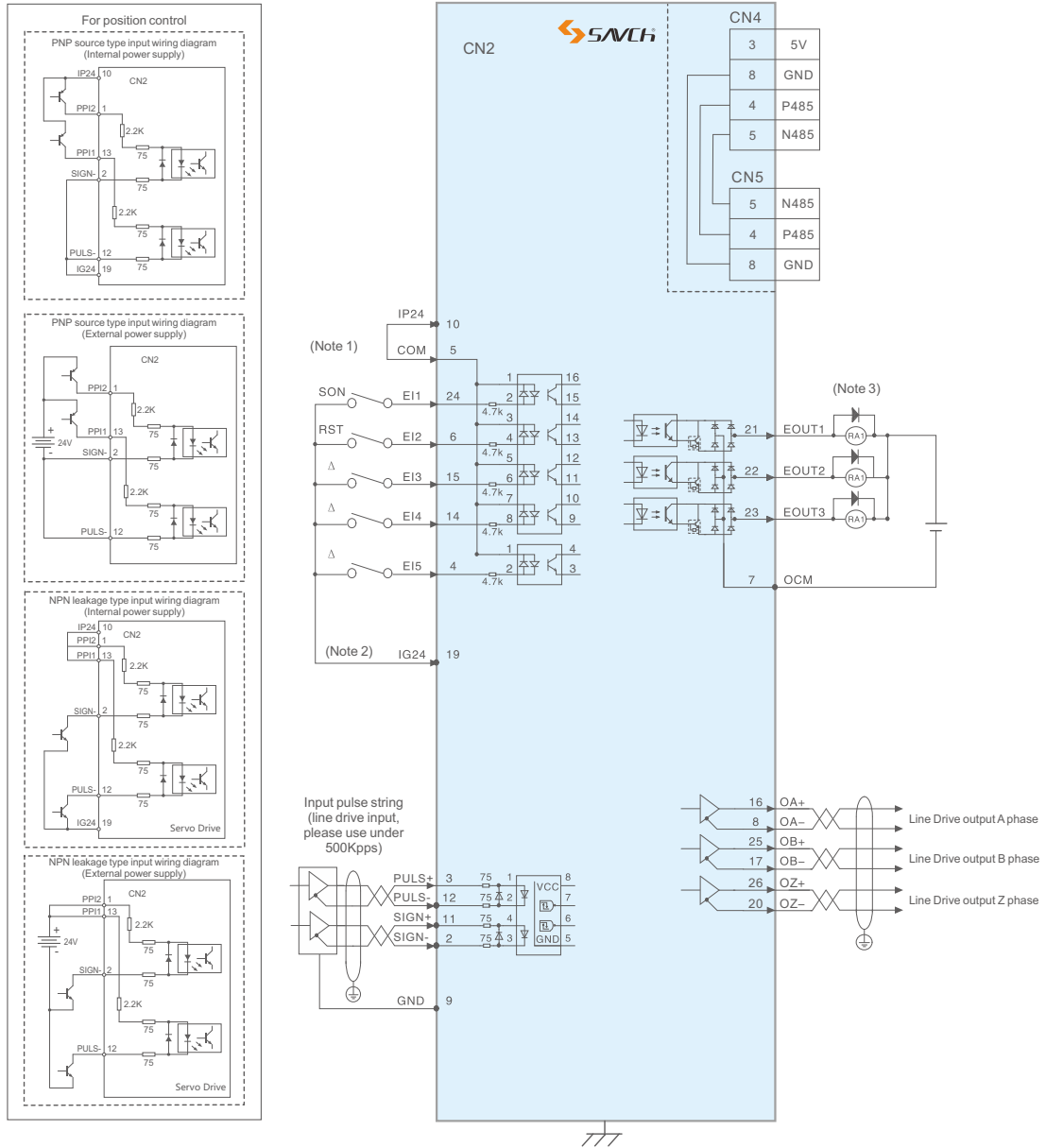

- Notes 1: When the external power supply are adopted, do not connect the COM with IP24, external power supply 24V connected to COM.
- Notes 2: The EI input terminal that is marked Δ indicates that the initial function is not defined, user can set the required function according to the "User Manual".
- Notes 3: The diode installation direction could not be connected by the wrong way, max working voltage 24V, max output current 50mA; the current value of external relay ring should be lower than 80mA. When the current value is greater than 80mA, the power should be supplied externally.
- Notes: The above picture is the reference picture for the selected model, please read the manual and relevant wiring guidance carefully.

• Speed Control Standard Wiring Diagram

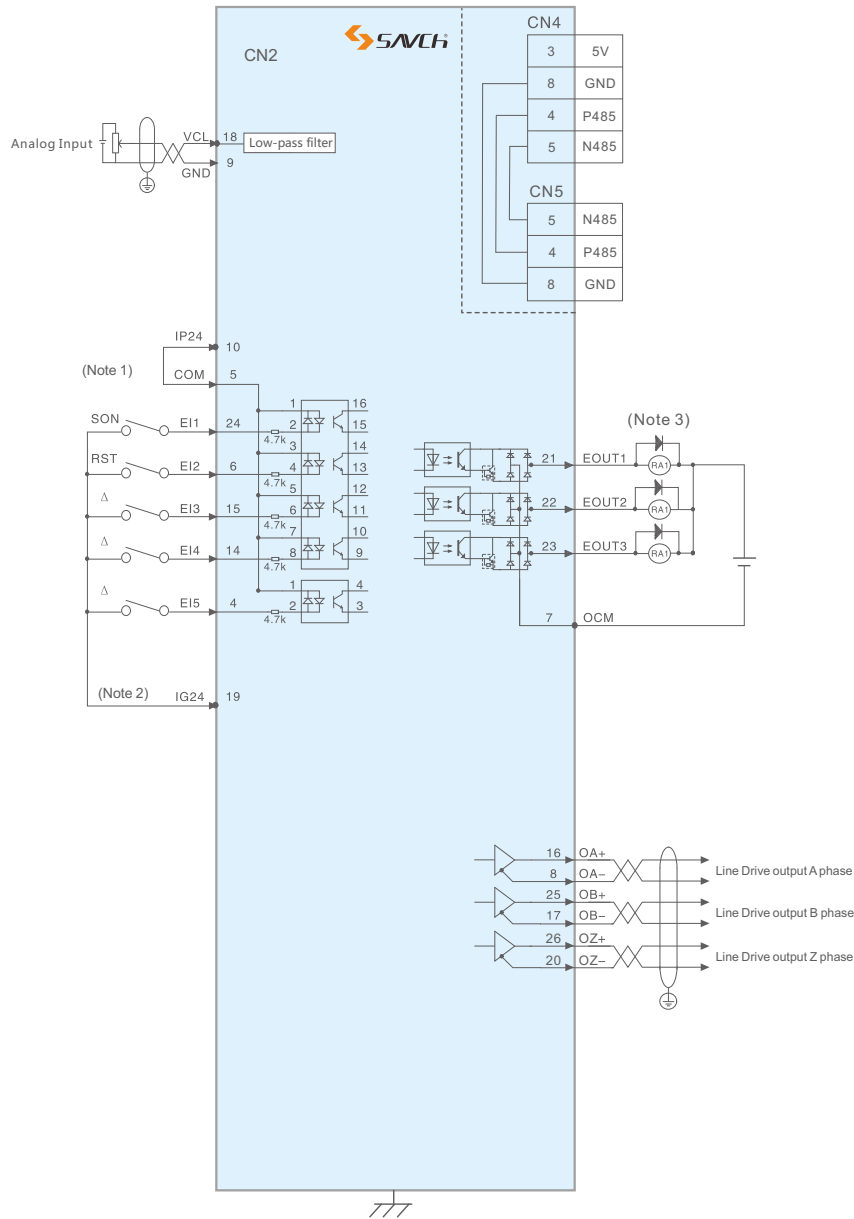

Wiring Diagram

- Notes 1: When the external power supply are adopted, do not connect the COM with IP24, external power supply 24V connected to COM.
- Notes 2: The EI input terminal that is marked Δ indicates that the initial function is not defined, user can set the required function according to the "User Manual".
- Notes 3: The diode installation direction could not be connected by the wrong way, max working voltage 24V, max output current 50mA; the current value of external relay ring should be lower than 80mA. When the current value is greater than 80mA, the power should be supplied externally.
- Notes: The above picture is the reference picture for the selected model, please read the manual and relevant wiring guidance carefully.

• Troque Control Standard Wiring Diagram

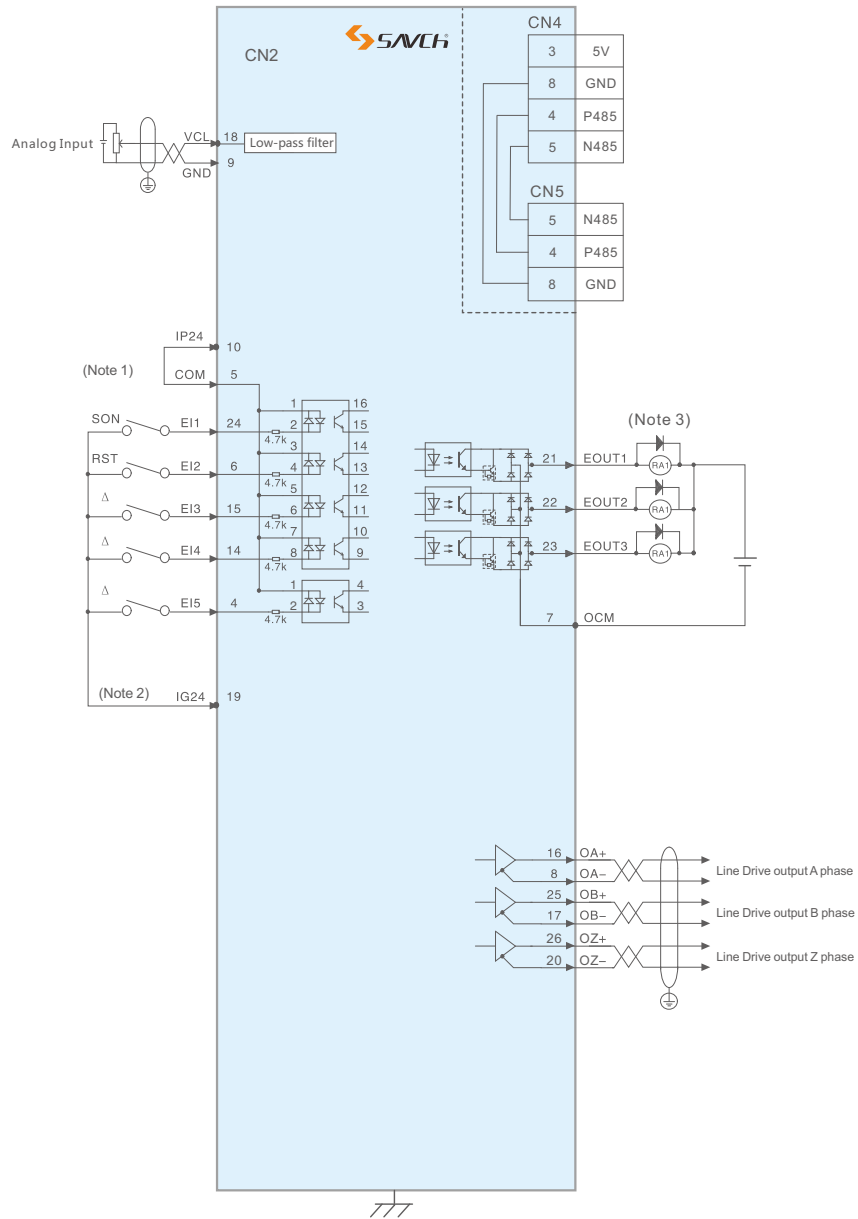

Notes 1: When the external power supply are adopted, do not connect the COM with IP24, external power supply 24V connected to COM.

Notes 2: The EI input terminal that is marked Δ indicates that the initial function is not defined, user can set the required function according to the "User Manual".

Notes 3: The diode installation direction could not be connected by the wrong way, max working voltage 24V, max output current 50mA; the current value of external relay ring should be lower than 80mA. When the current value is greater than 80mA, the power should be supplied externally.

Notes: The above picture is the reference picture for the selected model, please read the manual and relevant wiring guidance carefully.

# Servo Drive External Description

- Front View

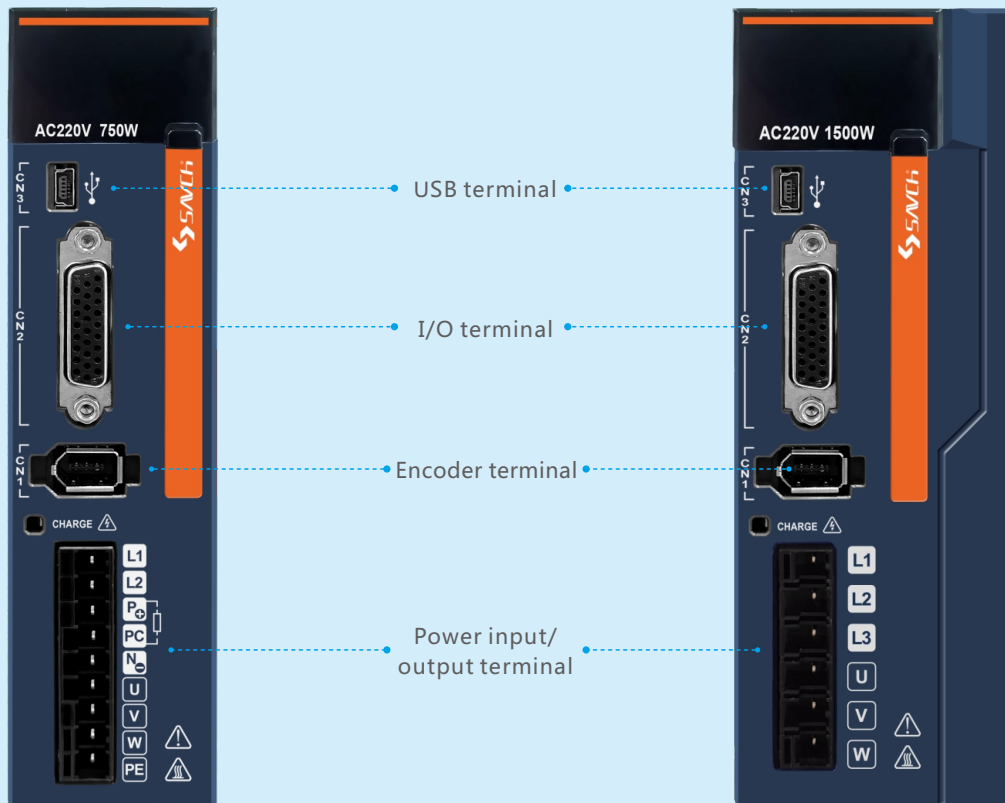

• Servo Drive External Dimension (Unit: mm)

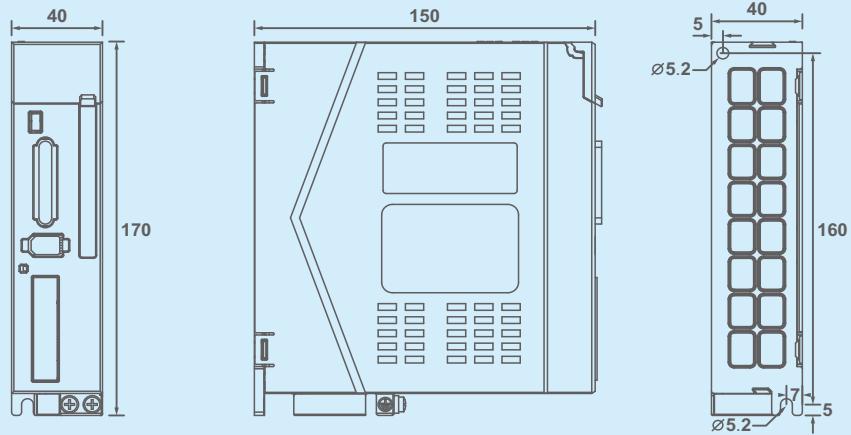

<b>Size 1</b>	2S	0.4G~0.75G
---------------	----	------------

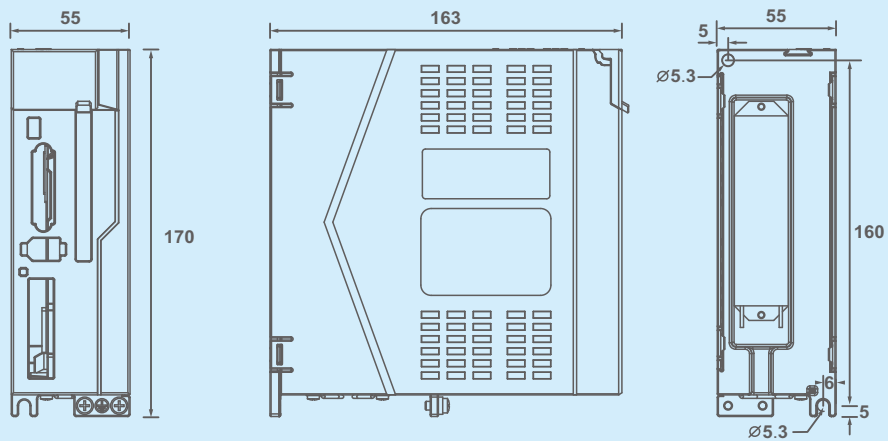

<b>Size 2</b>	2S	1.0G~1.5G
	4T	0.75G~2.0G

## Servo Motor Specification

- X series 220V
  - 60mm Series

Item	Servo Motor Model	
	SCH060201C	SCH060401C
Rated Output Power (W)	200	400
Applicable Servo Motor Driver	SDV3-2S0.4G	SDV3-2S0.4G
Rated Torque (N·m)	0.64	1.27
Rated Rotation Speed (R.P.M.)	3000	3000
Rated Current (A)	1.7	2.5
Rotor Inertia (kg·m <sup>2</sup> ×10 <sup>-4</sup> )	0.28	0.52
Instant Max Torque (N·m)	1.91	3.81
Max Rotation Speed (R.P.M.)	4500	4500
Insulation Level	F Class ( 155°C )	
Servo motor Ambient Temperature	-20°C~+40°C	
Permanent magnet brake	Brake Rated Voltage (V)	DC24±10%
	Brake Static Friction Torque (N·m)	2
	Brake Rated Power (W)	11

- 80mm Series

Item	Servo Motor Model	
	SCH080751C	SCH080102C
Rated Output Power (W)	750	1000
Applicable Servo Motor Driver	SDV3-2S0.75G	SDV3-2S1.0G
Rated Torque (N·m)	2.39	3.3
Rated Rotation Speed (R.P.M.)	3000	3000
Rated Current (A)	3.5	5.8
Rotor Inertia (kg·m <sup>2</sup> ×10 <sup>-4</sup> )	1.48	2.27
Instant Max Torque (N·m)	7.1	9.9
Max Rotation Speed (R.P.M.)	4500	4500
Insulation Level	F Class ( 155°C )	
Servo motor Ambient Temperature	-20°C~+40°C	
Magnetic Brake	Brake Rated Voltage (V)	DC24±10%
	Brake Static Friction Torque (N·m)	4
	Brake Rated Power (W)	18

- H series 220V
  - 110mm Series

Item	Servo Motor Model			
	SCH110122C	SCH110152C	SCH110122B	SCH110182C
Rated Output Power (W)	1200	1500	1200	1800
Applicable Servo Motor Driver	SDV3-2S1.0G	SDV3-2S1.5G	SDV3-2S1.0G	SDV3-2S1.5G
Rated Torque (N·m)	4	5	6	6
Rated Rotation Speed (R.P.M.)	3000	3000	2000	3000
Rated Current (A)	5	6	4.5	6
Rotor Inertia (kg·m <sup>2</sup> ×10 <sup>-4</sup> )	5.4	6.3	7.6	7.6
Instant Max Torque (N·m)	12	15	12	18
Max Rotation Speed (R.P.M.)	3600	3600	2400	3600
Weight (kg)	6	6.8	7.9	7.9
Insulation Level	F Class ( 155°C )			
Servo motor Ambient Temperature	-20°C~+40°C			
Magnetic Brake	Brake Rated Voltage (V)	DC24±10%		
	Brake Static Friction Torque (N·m)	8		
	Brake Rated Power (W)	15		

- 130mm Series

Item	Servo Motor Model				
	SCH130102E	SCH130132E	SCH130152E	SCH130102A	SCH130152H
Rated Output Power (W)	1000	1300	1500	1000	1500
Applicable Servo Motor Driver	SDV3-2S1.0G	SDV3-2S1.0G	SDV3-2S1.5G	SDV3-2S1.0G	SDV3-2S1.5G
Rated Torque (N·m)	4	5	6	10	10
Rated Rotation Speed (R.P.M.)	2500	2500	2500	1000	1500
Rated Current (A)	4	5	6	4.5	6
Rotor Inertia (kg·m <sup>2</sup> ×10 <sup>-4</sup> )	8.5	10.6	12.6	19.4	19.4
Instant Max Torque (N·m)	12	15	18	20	25
Max Rotation Speed (R.P.M.)	3000	3000	3000	1200	1800
Weight (kg)	6.2	6.6	7.4	10.2	10.2
Insulation Level	F Class ( 155°C )				
Servo motor Ambient Temperature	-20°C~+40°C				
Magnetic Brake	Brake Rated Voltage (V)	DC24±10%			
	Brake Static Friction Torque (N·m)	16			
	Brake Rated Power (W)	25			

- X series 380V
  - 80mm Series

Item	Servo Motor Model	
	SCH080751C	SCH080102C
Rated Output Power (W)	750	1000
Applicable Servo Motor Driver	SDV3-4T1.0G	SDV3-4T1.0G
Rated Torque (N·m)	2.39	3.3
Rated Rotation Speed (R.P.M.)	3000	3000
Rated Current (A)	3.0	3.7
Rotor Inertia (kg·m <sup>2</sup> ×10 <sup>-4</sup> )	1.48	2.27
Instant Max Torque (N·m)	7.1	9.9
Max Rotation Speed (R.P.M.)	4500	4500
Insulation Level	F Class ( 155°C )	
Servo motor Ambient Temperature	-20°C~+40°C	
Magnetic Brake	Brake Rated Voltage (V)	DC24±10%
	Brake Static Friction Torque (N·m)	4
	Brake Rated Power (W)	18

- H series 380V
  - 110mm Series

Item	Servo Motor Model			
	SCH110122C	SCH110152C	SCH110122B	SCH110182C
Rated Output Power (W)	1200	1500	1200	1800
Applicable Servo Motor Driver	SDV3-4T1.0G	SDV3-4T1.5G	SDV3-4T1.0G	SDV3-4T1.5G
Rated Torque (N·m)	4	5	6	6
Rated Rotation Speed (R.P.M.)	3000	3000	2000	3000
Rated Current (A)	3.0	4.5	3.0	4.5
Rotor Inertia (kg·m <sup>2</sup> ×10 <sup>-4</sup> )	5.4	6.3	7.6	7.6
Instant Max Torque (N·m)	12	15	12	18
Max Rotation Speed (R.P.M.)	3600	3600	2400	3600
Weight (kg)	6	6.8	7.9	7.9
Insulation Level	F Class ( 155°C )			
Servo motor Ambient Temperature	-20°C~+40°C			
Magnetic Brake	Brake Rated Voltage (V)	DC24±10%		
	Brake Static Friction Torque (N·m)	8		
	Brake Rated Power (W)	15		



- H series 380V
  - 130mm Series

Item	Servo Motor Model			
	SCH130102E	SCH130132E	SCH130152E	SCH130202E
Rated Output Power (W)	1000	1300	1500	2000
Applicable Servo Motor Driver	SDV3-4T1.0G	SDV3-4T1.0G	SDV3-4T1.5G	SDV3-4T2.0G
Rated Torque (N·m)	4	5	6	7.7
Rated Rotation Speed (R.P.M.)	2500	2500	2500	2500
Rated Current (A)	2.6	3.0	4.0	4.7
Rotor Inertia (kg·m <sup>2</sup> ×10 <sup>-4</sup> )	8.5	10.6	12.6	15.3
Instant Max Torque (N·m)	12	15	18	22
Max Rotation Speed (R.P.M.)	3000	3000	3000	3000
Weight (kg)	7.7	8.2	8.9	10.0
Insulation Level	F Class ( 155°C )			
Servo motor Ambient Temperature	-20°C~+40°C			
Magnetic Brake	Brake Rated Voltage (V)	DC24±10%		
	Brake Static Friction Torque (N·m)	8		
	Brake Rated Power (W)	15		

Item	Servo Motor Model			
	SCH130102A	SCH130152H	SCH130262E	SCH130232H
Rated Output Power (W)	1000	1500	2600	2300
Applicable Servo Motor Driver	SDV3-4T1.0G	SDV3-4T1.5G	SDV3-4T2.0G	SDV3-4T2.0G
Rated Torque (N·m)	10	10	10	15
Rated Rotation Speed (R.P.M.)	1000	1500	2500	1500
Rated Current (A)	2.5	3.5	6.0	5.0
Rotor Inertia (kg·m <sup>2</sup> ×10 <sup>-4</sup> )	19.4	19.4	19.4	27.7
Instant Max Torque (N·m)	20	25	25	30
Max Rotation Speed (R.P.M.)	1200	1800	3000	1800
Weight (kg)	10.1	12.1	9.1	12.6
Insulation Level	F Class ( 155°C )			
Servo motor Ambient Temperature	-20°C~+40°C			
Magnetic Brake	Brake Rated Voltage (V)	DC24±10%		
	Brake Static Friction Torque (N·m)	16		
	Brake Rated Power (W)	25		

# Servo Motor External Dimension

• 60mm Series

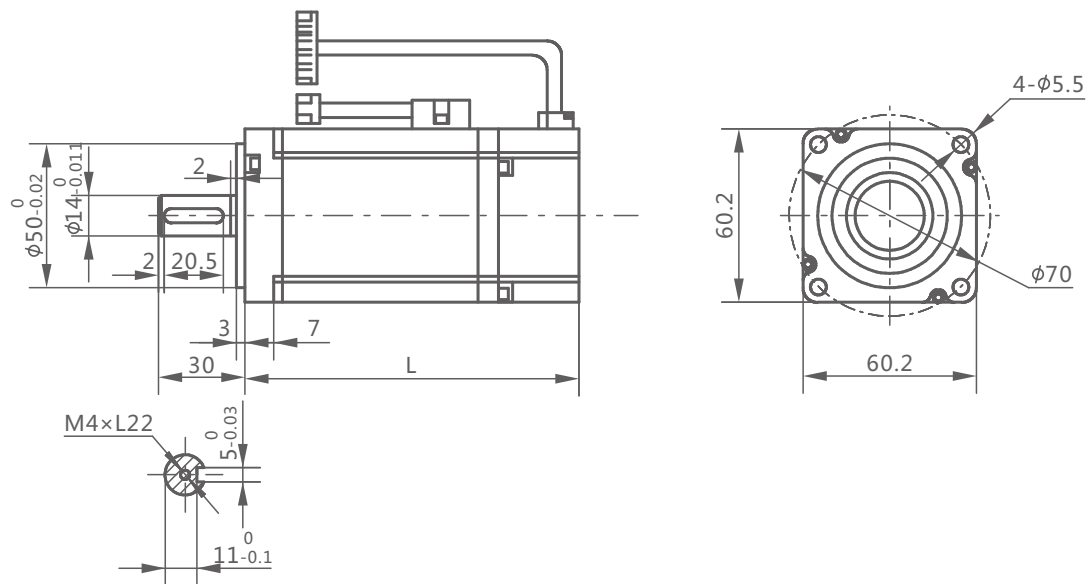

■ 220V

Model	SCH060201C	SCH060401C
L (Without Brake)	75	92
L (With Brake)	105	122

• 80mm Series

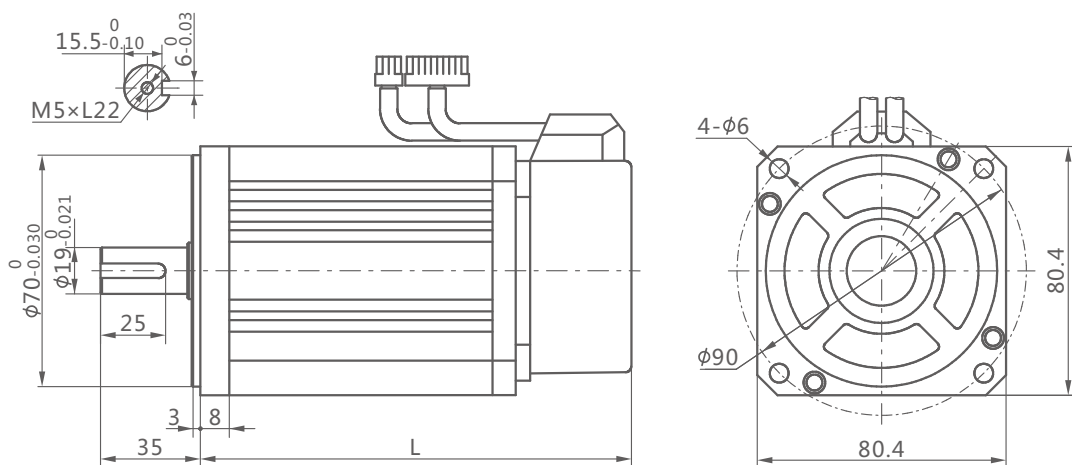

■ 220V/380V

Model	SCH080751C	SCH080102C
L (Without Brake)	100	113
L (With Brake)	134	147

• 110mm Series

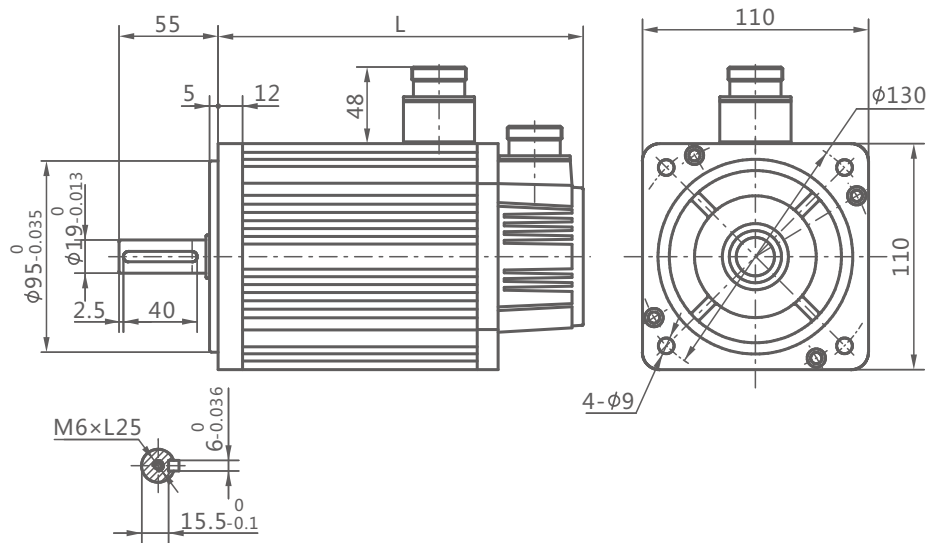

▪ 220V/380V

Model	SCH110122C	SCH110152C	SCH110122B	SCH110182C
L (Without Brake)	189	204	219	219
L (With Brake)	254	269	284	284

• 130mm Series

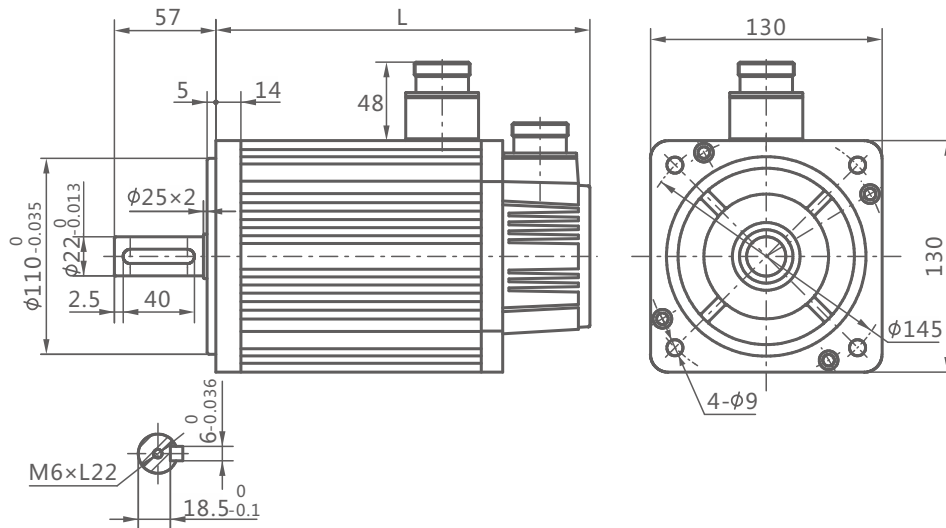

▪ 380V



Model	SCH130202E	SCH130262E	SCH130232H
L (Without Brake)	192	209	241
L (With Brake)	252	272	304

▪ 220V/380V

Model	SCH130102E	SCH130132E	SCH130152E	SCH130102A	SCH130152H
L (Without Brake)	166	171	179	213	213
L (With Brake)	226	231	239	276	276

# Options

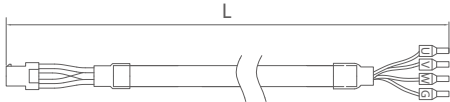
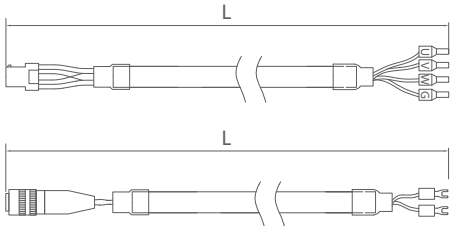
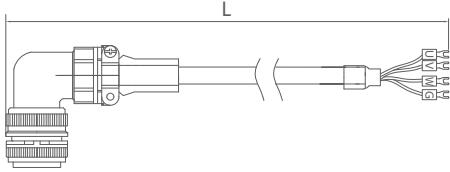
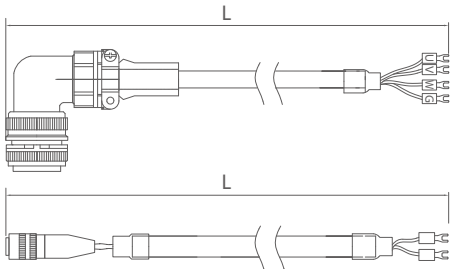
• Cable (Note: L: Cable length, Unit: m)

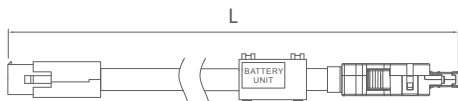
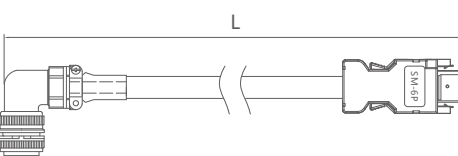
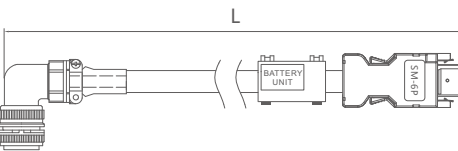
Cable Model		Reference Sample	Matched Motor
DL-SCH086(ZD1V)-N-L	Without Brake		SCH060 to SCH090
DL-SCH086(ZD1V)-B-L	With Brake		
DL-SCH130(ZD1V)-N-L	Without Brake		SCH110 to SCH130
DL-SCH130(ZD1V)-B-L	With Brake		
SA2FK-P1S(ZD1Y)-L			SCH060 to SCH090
SA2FK-P1D(ZD1Y)-L			
SA2FK-P2S(ZD1Y)-L			SCH110 to SCH130
SA2FK-P2D(ZD1Y)-L			

• Power Cable Type Description

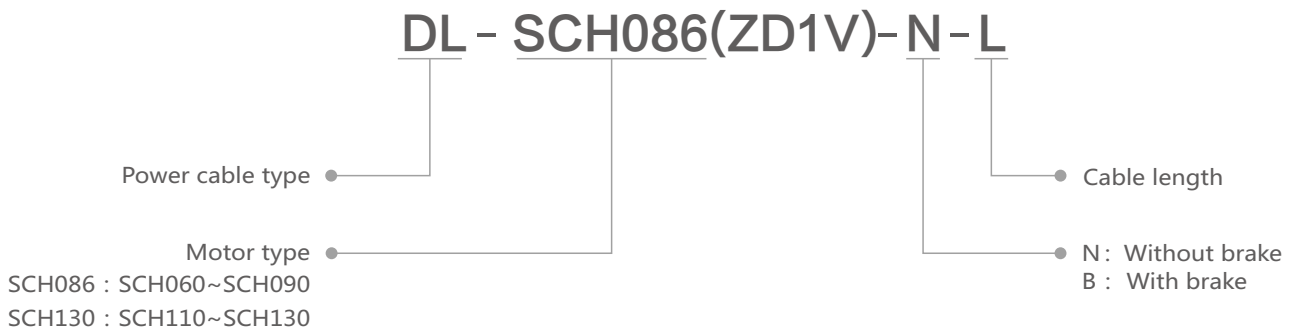

• Feedback Cable Type Description



COOPERATIVE CLIENT



☑ **Quanzhou Factory** \_\_\_\_\_  
Address: 3# Zixin Road, Jiangnan Hi-Tech Industrial Park,  
Quanzhou, Fujian, China  
Tel: **+86 595 24678267** Fax: **+86 595 24678203**

☑ **Service Network** \_\_\_\_\_  
Website: **www.savch.net**

☑ **Qualification** \_\_\_\_\_  
Received **ISO9001** and **CE** recognition  
520633243801 V1.1 2023-07-26  
All rights reserved. Subject to change without further notice.

Sales service contact address



SAVCH Wechat