

SDV3 Series Servo System

General purpose

User Manual



SDV3 Series Servo System

General purpose

User Manual

File No. 520033243800

Vision No. V1.0

Filing time 2023-04-07

SAVCH electric provide a full range of technical support for our customers.

All users could contact with the nearest SAVCH office or service center,
also could contact with our headquarters directly.

SAVCH Electric reserves the copyrights and all rights,

Subject to change without further notice.

CONTENT

Preface	1
1 Safety Precautions	3
1.1 Notes for Operation	3
1.2 Notes for Operation Environment	5
2 Hardware Description and Installation	6
2.1 Operation Environment	6
2.2 Model Description	10
2.3 Product Specification	11
2.4 Servo Motor Rotation Direction Definition	12
2.5 Basic Wring Diagram	13
2.6 External Dimensions	16
2.7 Basic Wiring Diagram Under Different Control Modes	18
2.8 Interfaces	21
2.9 Input / Output Interface Type	24
3 Description of Keypad Functions	30
3.1 Description of Keypad Functions	30
3.2 List of Descriptions for Functional Parameters	32
3.3 Control Status Display Mode	34
3.4 Monitor Mode	35
3.5 Alarm Mode	40
3.6 Parameter Edit Mode	42
3.7 Positioning Data Edit Mode	45
3.8 Test Operation Mode	48
4 Operation	58
4.1 Signal Description (Input Signal Order)	58
4.2 Operation Procedure	59
4.3 Operation Check	60
4.4 Operation	62
5 List of Function Parameter	77
5.1 Parameter Division	77
5.2 List of Function Parameter	77
6 Detail Description of Function Parameter	86
6.1 Basic Setting Parameters (P1.01~50)	86
6.2 Control Gain and Filter Setting Parameters (P1.51~99)	102
6.3 Automatic Operation Setting Parameters (P2.01~50)	111
6.4 Extended Function Setting Parameters (P2.51~99)	126
6.5 Input Terminal Function Setting Parameters (P3.01~50)	134
6.6 Output Terminal Function Setting Parameters (P3.51~99)	151



6.7 Application Function Parameters (P4.01~99)	164
7 Communications	165
7.1 Settings for Servo Motor Drive	165
7.2 Communication Specifications	166
7.3 Transmission Protocol	167
8 Script Function	181
9 Maintenance and Inspection	182
9.1 Inspection	182
9.2 Status Display	182
9.3 Troubleshooting Method	184
10 Servo motor	192
10.1 SCH Series AC Permanent-Magnet Servo Motor	192
10.2 Servo Motor Model Description	192
10.3 Servo Motor Specification	193
10.4. Servo Motor External Dimension	197
10.5 Delivery and Storage	199
10.6 Wiring	199
11 Options	200
11.1 About Optional Parts	200
11.2 Standard Configuration for Drive Braking parts	200
11.3 Optional Regenerative Or Braking Parts	200

Thank you for choosing SAVCH servo motor & drive! This instruction manual, which includes operation descriptions and notes for maintenance, shall be delivered to the end-user.

For safety running and effective operation, this instruction manual shall be read thoroughly prior to use, which shall also be preserved for later use. Provided problems occur and solution is not provided in this instruction manual, contact your SAVCH ELECTRIC representative or contact with our company directly. Our professional technicians will serve for you actively. And please continue to adopt products of SAVCH, give valuable opinion and advice.

1. Reading Instructions

Symbols of" DANGER" and" CAUTION" in the manual indicates that, for safety running or maintenance of servo motor drive or other electrical products, attention shall be attached during deliver, installation, operation and checks for the servo motor drive. And these notes shall be applied for a better and safer operation.

 DANGER	If not used correctly, personnel damage even death may be caused.
 CAUTION	If not used correctly, serious damage to servo motor drive or machine may be resulted.

 DANGER
<ul style="list-style-type: none">●Never connect wires while power on. Do not check components or signal for circuit board During operation.●Do not dismantle or change servo motor drive wire, circuit or components.●Make sure grounding terminals are correctly grounded.

 CAUTION
<ul style="list-style-type: none">●Do not perform a withstand voltage test for components of servo motor drive, it can cause semi-conductor components to be damaged by high voltage.●Never connect the output terminals U, V, W to AC power.●CMOS IC on control circuit of the servo motor drive shall be damaged by electrostatic influence. Do not touch main circuit board.

2. Products Receiving

All products have been performed with strict test and inspection. After receiving the servo motor drive, the following checks shall be performed.

- To check that SAVCH servo motor drive, an instruction manual is inside of the package
- To check whether model number correspond with model and capacity your purchase order.
- To check whether there are damaged parts during transportation and deliver. If there are, do not connect with power.

If any of the above checkpoints are not satisfactory, contact your SAVCH ELECTRIC representative for a quick resolution.

3. About the User Manual

Description feed in this user manual may be inconsistent to the product due to improvement added to the product. Additionally, description feed in this manual is subject to change without further notice.

The illustrations in user manual are about some specified capacity of the servo motor drive or servo motor, and they may be different with the product you purchase.

4. Icon Description

Note	Negligence of description shown with this sign will undermine the true performance of the product.
Tip	Reference items helpful for operation and data setting of the servo motor and servo motor drive are described.

1.1 Notes for Operation

Installation Precautions

⚠ CAUTION

- Do not step on the servo motor or place a heavy matter on it.
- Do not block the exhaust port or put the foreign particles into them.
- Observe the installation method and direction of the servo motor drive.
- Do not give strong impact shock to it.
- The shaft-through hole of the servo motor is not water proof or oil proof. Take measures on the machine side to block entry of water, coolant or similar from enter inside the servo motor.
- If case of application when massive water or oil is splashed on the main body of the servo motor, install a water or oil splash guard or take similar measures on the machine side.
- In a humid and high oil mist environment, install the lead wires and connectors in a face down orientation.

Wiring Precautions

⚠ CAUTION

- Perform ground wires to prevent electric shock and fire hazards.
- Do not connect the 220V drive power to the 380V power, otherwise it may cause an electric shock or damage to the equipment or fire hazards.
- Do not connect three-phase power to the output terminals U、 V、 W, otherwise, it may cause injuries or fire.
- Connect the output terminals U、 V、 W with wiring terminals U、 V、 W respectively, otherwise, it may cause damage to the equipment due to the racing of the servo motor and injuries.
- Please tightly fix the power to the output terminal, otherwise, it may cause the fire hazard.
- Refer to the cable for the wiring to prevent the accidents.

Operation Precautions

⚠ CAUTION

- Specify the proper function parameter data in accordance with the machinery equipment before it starts the operation, otherwise, it may cause out of control or breakdown.
- Confirm the quick stop function is available before operating the servo motor drive.
- Check whether the servo motor can operate under no-load state first, after that, make the servo motor running with load to avoid any unnecessary loss.
- Do not turn on or turn off the power frequently, otherwise, it may cause inside overheat of servo motor drive.

Test Run Precautions

CAUTION

- Do not connect with the machine when the servo motor drive is having the test run.
- Fix the servo motor when the servo motor drive is having test run, since the servo motor may cause an impact to the machine During acceleration and deceleration.
- Please do not perform the switching frequently when it is power on, it is better to keep the frequency of turn on/off in 2 times per hour and daily with 10 times or below.

Running Precautions

DANGER

- When the servo motor is running, do not touch any running parts, otherwise, it may cause personal injury.
- When the machinery equipment is running, do not touch the servo motor and servo motor drive, otherwise, it may cause an electric shock or burn.
- When the machinery equipment is running, do not move the cable, otherwise, it may cause personal injury or damage to the equipment.

Maintenance and Inspection Precautions

DANGER

- Do not touch the inside of the servo motor drive and servo motor, otherwise, it may cause an electric shock.
- Do not remove servo motor drive control panel when it is power on, otherwise, it may cause an electric shock.
- Do not touch the wire terminal when the power is turned off in 5 minutes, otherwise, the residual high voltage may cause an electric shock.
- Do not change the wiring when it is power on, otherwise, it may cause an electric shock.
- Do not remove the servo motor, otherwise, it may cause an electric shock.

Using Range Precautions

CAUTION

- This instruction manual is for industrial general purpose, such as the nuclear equipment, aerospace equipment, life support and maintain equipment and other safety equipment etc., if you have any requirements, please contact with our company directly
Please do not use it on the equipment that is dangerous to the human safety.

Disposal Precautions

CAUTION

- The electrolytic capacitor on the main circuit and PCB may cause an exposition when burning and the control panel or plastic parts may cause the poisonous gas, please dispose them as the industrial rubbish.

1.2 Notes for Operation Environment

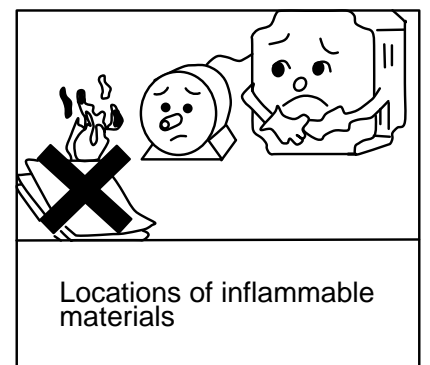
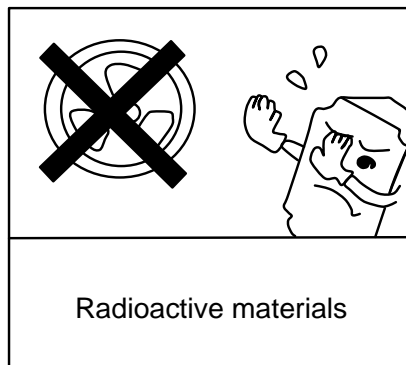
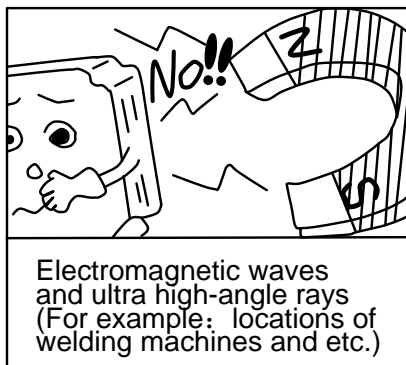
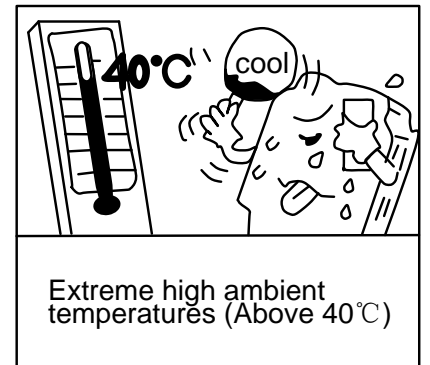
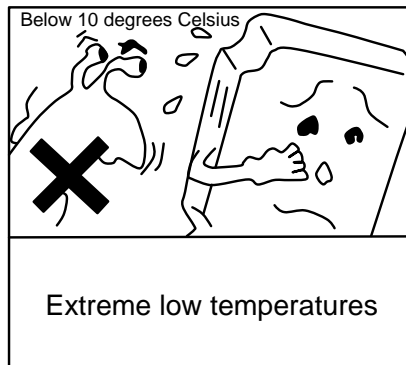
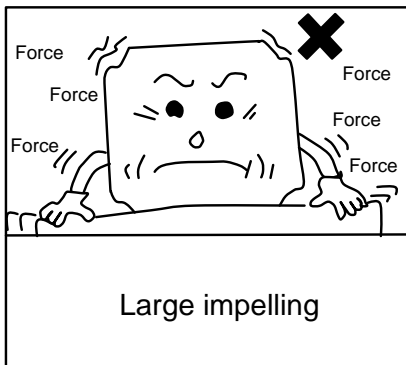
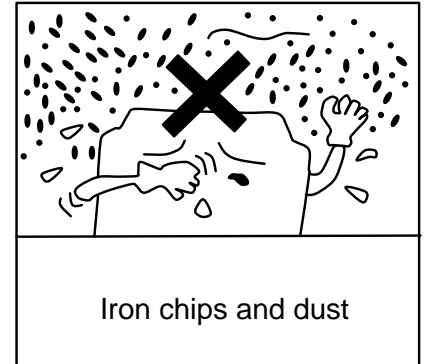
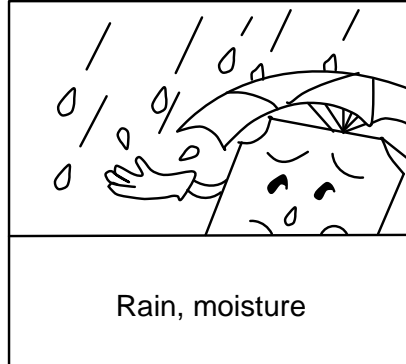
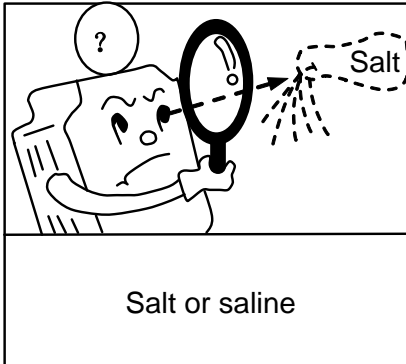
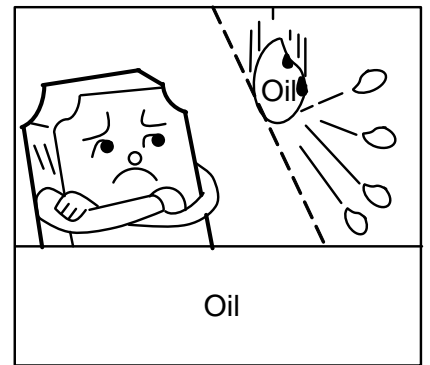
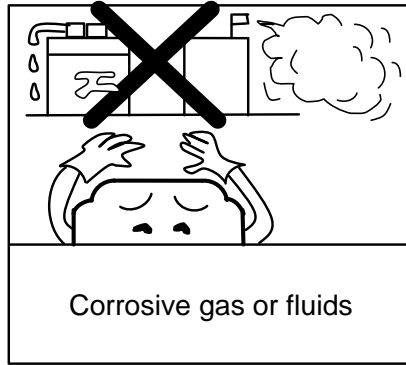
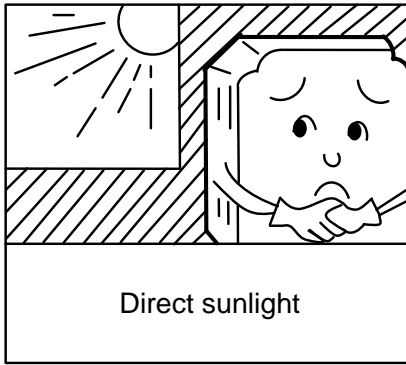

2 Hardware Description and Installation

2.1 Operation Environment

2.1.1 Servo motor drive installation and environment

Since operation environment can directly influence functions and operation life, to ensure proper performance and long operation, follow the recommendations below when choosing allocation for installing the servo motor drive:

- Ambient temperature:0°C ~ + 50°C; Ambient humidity:Below 90% RH (no condensation)
- Storage temperature:-20 ~ +75°C; Storage humidity:Below 90% RH (no condensation)
- Vibration :Below 0.5G
- Avoid Rain, moisture
- Avoid Direct sunlight.(Avoid using outdoors)
- Corrosion of oil sprays or salt
- Corrosive gases and methane
- Dust or lint and metallic particles in the air
- Radioactive materials and inflammable materials
- When assembling the servo motor drive, try to prevent the drillings and other foreign materials dropping in the servo motor drive.
- In the installation, please ensure to fasten with the M4 screws.
- When there is vibration source (punch) around and it can not be avoided, please use the resonance absorber or anti-vibration rubber gasket.
- When there are strong noise and interference sources around the servo motor drive, such as the big magnetic switches, butt fusion welding machine etc., the servo motor drive will be easily be disturbed, causing the error operation, so the noise filter is required at that time. However, the noise filter increases the leakage current, therefore the transformer is required to be installed on the input terminal of the servo motor drive.

2.1.2 Servo motor drive installation direction and interval

- For cooling off, please install the servo motor drive vertically standing way, face shall be toward front and upper parts shall be upwards. Or the performance will decline and the service life will be shortened.
- When the servo motor drive is installed in the control cabinet, the stated clearance should be left between servo motor drive and control cabinet inside walls, and other machines to get enough air for the cooling; Besides, install an additional cooling fan to ensure that the environment temperature around the servo motor drive is lower than 50°C, otherwise, the performance will decline, and the service life will be shortened.

2.1.2.1 The occasion with one servo motor drive

Control cabinet

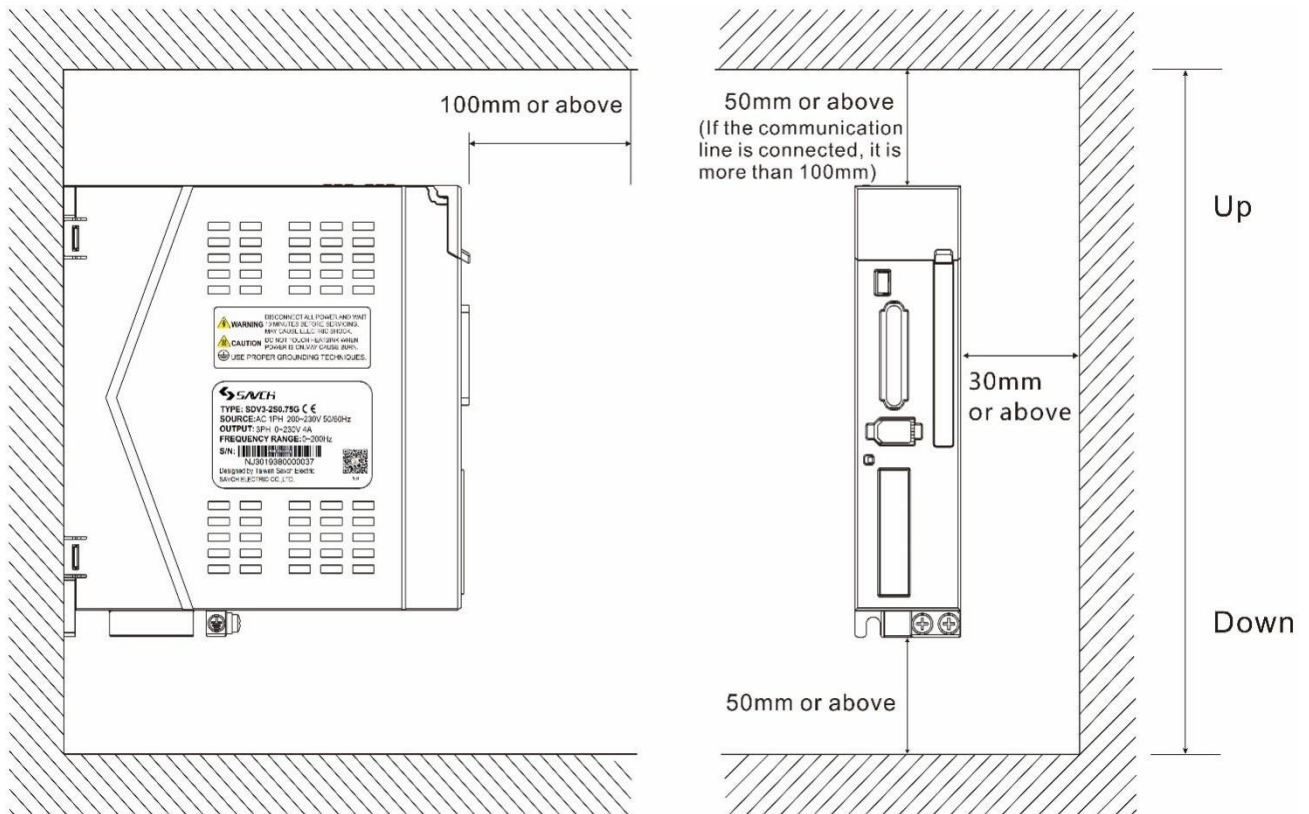

2.1.2.2 Occasions with 2 or over 2 servo motor drives

Big enough intervals should be left between servo motor drives and between them and control cabinet inside walls, air inlet and out let should be left on cabinet body. It is suggested that a fan with enough ventilation to reduce the internal temperature of control cabinet as possible. As follows:

Control cabinet

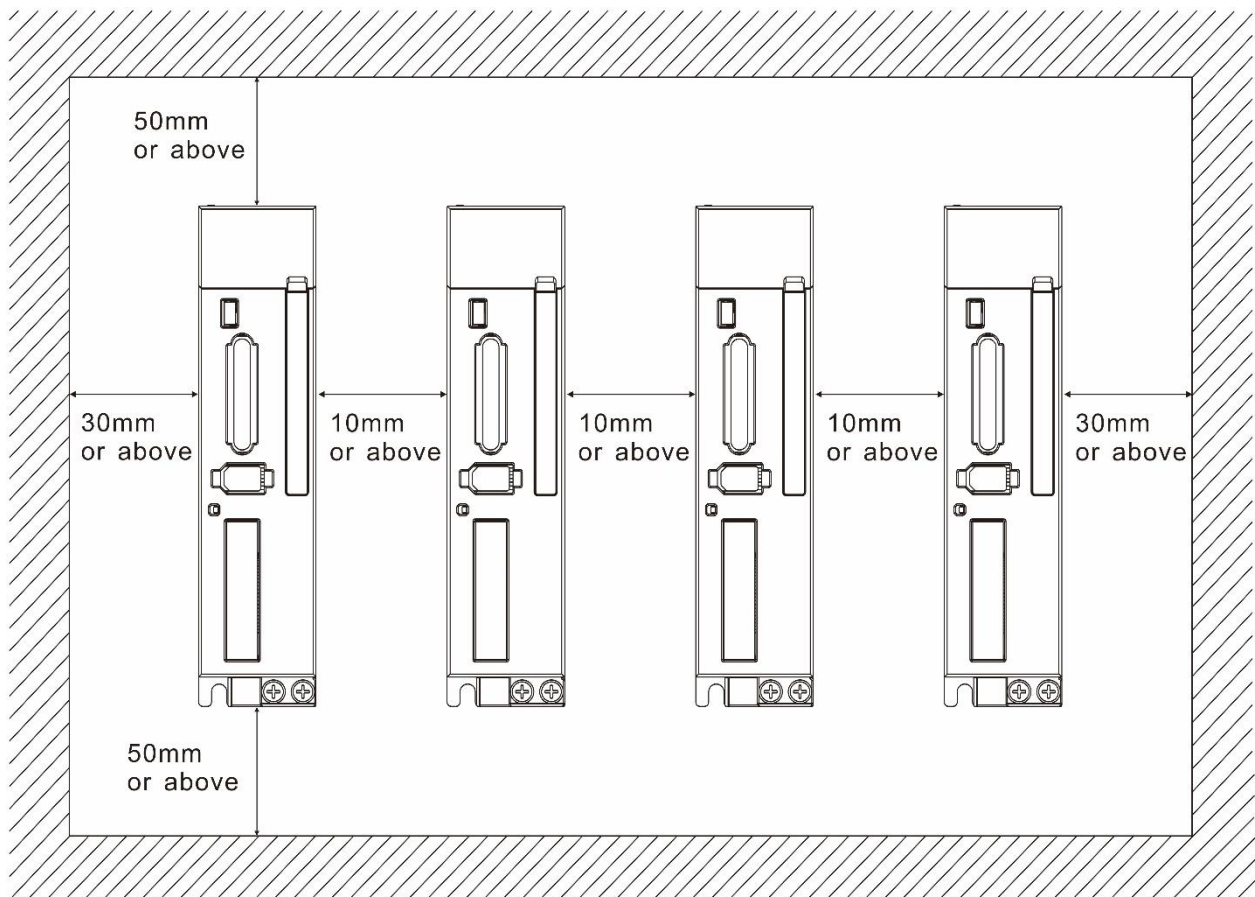

2.1.2.3 Others

Heat dispersion shall be taken into consideration when using regenerative resistor and heating parts, in order to avoid the impact to the servo motor drive.

2.1.3 Installation environment conditions and methods of servo motor

2.1.3.1 Installation environment conditions

- Ambient temperature:-10 ~ +40°C ; Ambient temperature:Below 90% RH (no condensation)
- Storage temperature:-20 ~ +60°C ; Storage temperature:Below 90% RH (no condensation)
- Vibration :Below 2.5G
- Draught, less humidity and dirty
- No corrosive, incendivity gas, oil-gas, cutting fluid, cutting powder, iron powder etc.
- No steam and direct sunlight

2.1.3.2 Installation method

- Horizontal installation

Please install the cable outlet under the servo motor to avoid the water, oil and other liquid to inflow into the inside of the servo motor through the output cable.

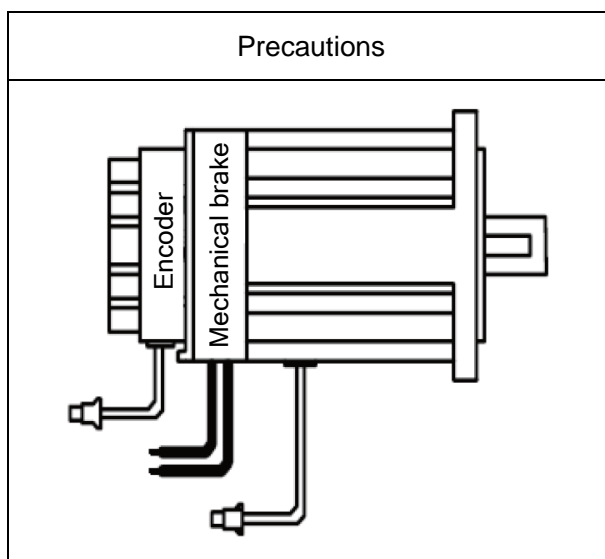

- Vertical installation:

If the servo motor shaft is mounted facing up and with a reducer, please use the servo motor with oil seal to avoid the oil leftover of the reducer to inflow into the inside of the servo motor through the servo motor axis.

2.1.3.3 Other

1. Please ensure that the cable is kept dry.
2. To avoid falling off and break of the wires due to mechanical movement, please ensure to fix the wires.
3. Please ensure enough protrusion for the servo motor axis, otherwise, the servo motor movement is easy to cause the vibration.

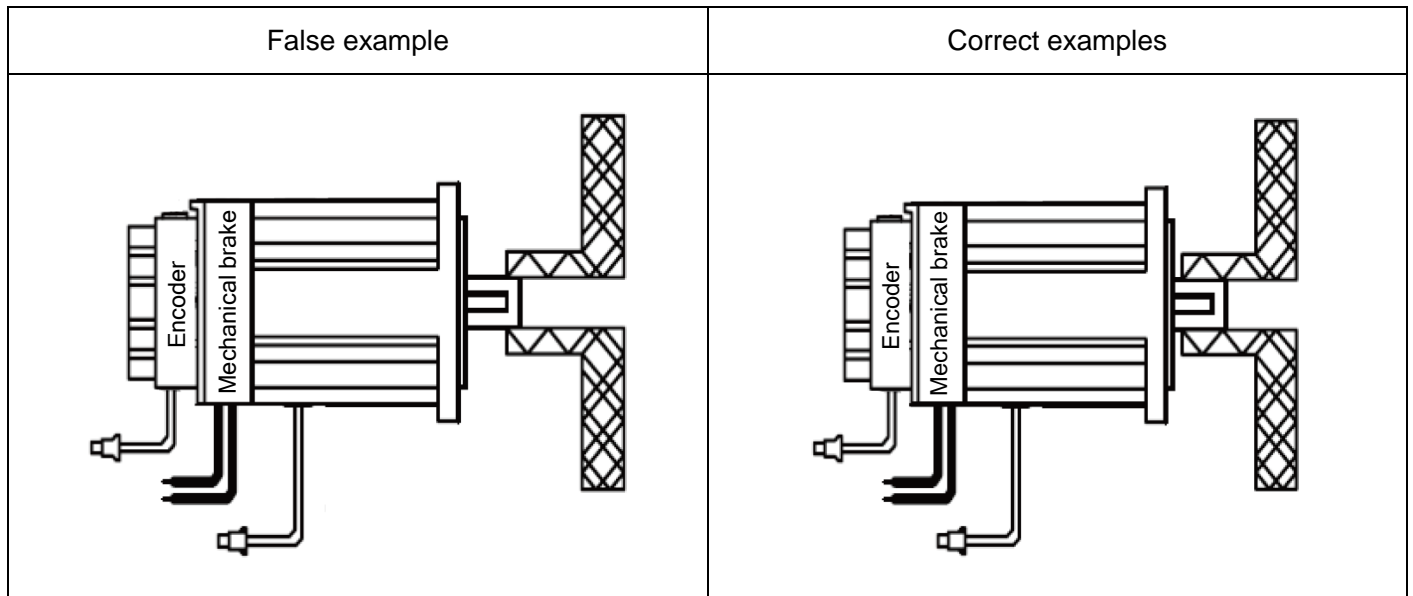

4. Please do not strike the servo motor with the hammer when you are installing or removing the servo motor, otherwise, the servo motor axis and back-encoder will be easily damaged.

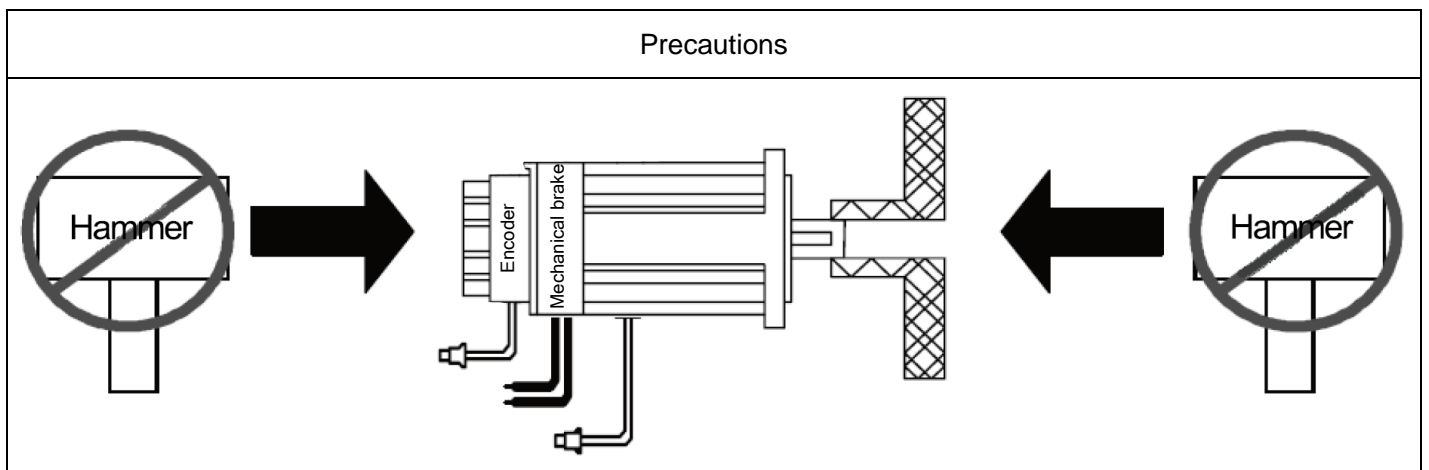

2.2 Model Description

2.2.1 Nameplate

Model → TYPE: SDV3-2S0.4G

Input power supply Spec → SOURCE: AC 1PH 200~230V 50/60Hz

Output power supply Spec → OUTPUT: 3PH 0~230V 2.7A

Output frequency → FREQUENCY RANGE: 0~250Hz

S/N: NJ301938000037

NJ301938000037

Designed by Savch Electric
SAVCH ELECTRIC CO.,LTD.

1.0

2.2.2 Model Description



2.3 Product Specification

Model		SDV3-□□□□ G
Input Power		Single phase 220V / Three phase 380V
		Voltage variation range (-15%~+10%) 50/60Hz
Cooling Method		Fan Cooling
Main circuit control mode		Sinusoidal PWM drive
Feedback		17 bit INC/20 bit INC
Control Mode		①Position control, ②Speed control, ③ Torque control, ④Position/speed mode switch, ⑤Position/torque mode switch, ⑥Speed/torque mode switch, ⑦Positioning operation mode
Position control	Max input pulse frequency	Line Drive input :Max 500kHz Open Collector Input: Max 200kHz
	Command pulse input mode	①Command pulse/command signal , ②Forward rotating pulse and reverse rotating pulse, ③A/B phase orthogonal pulse
	Command control mode	①External command pulse input control, ②Internal position data control
	Electronic Gear	Electronic Gear N/M times(N:1~4194304)/M:1~4194304)
	Torque Limitation	Parameter control(Forward rotating and reverse rotating can be set respectively)/External analog torque control
Speed control	Analog command input	VCL 0~±10VDC
	Speed Variation Rate	±1r/min or below(load range 0~100%)
	Speed range	1:5000
	Acceleration and deceleration time setting	Acceleration time and deceleration time can be set respectively, and have two groups, and can accelerate and decelerate with S curve
	Speed control mode	External analog input,Parameter setting,Communication speed command,Command pulse frequency
	Torque Limitation	Parameter control(Forward rotating and reverse rotating can be set respectively)/External analog torque control
Torque control	Analog command input	VCL 0~±10VDC
	Speed Limitation	Parameter control/External analog speed limitation
Digital input/output	Input	EI1~EI5 5 lines input, the function can be set freely according to the parameter
	Output	Encoder pulse outputs by frequency division, A/B/Z output by line drive EOUT1~EOUT3 3 lines output, the function can be set freely according to the parameter

Model		SDV3-□□□□ G
Monitor		Feedback speed, reference speed, reference torque, motor current, feedback of current location , Location Difference, reference pulse frequency, Feedback Pulse Accumulation, Reference Pulse Accumulation, VREF input voltage, TREF input voltage, input terminal signal, output terminal signal etc
Protection(Alarm display)		Overcurrent (oc1, oc2)、 Over speeding(oS)、 Overvoltage(Hv)、 Memory Error (dE)、 Encoder Error(Ec)、 Overload(oL1, oL2)、 Main circuit under voltage(Lu)、 EI Repeat(ctE)、 Deviation overflow (oF)、 Servo motor drive overheat(AH) etc.
Application Environment	Site location	Indoors (Avoid direct sunlight), No corrosive gas (Avoid smoke, methane)
	Ambient Temperature	0~50 °C (When the ambient temperature is higher than the required one, please introduce air circulation)
	Storage Temperature	-20°C ~75°C
	Relative humidity	RH 90% lower (No condensation)
	Altitude	Lower than 1000m
	Atmospheric pressure	86~106kPa
	Vibration	≤0.5G

2.4 Servo Motor Rotation Direction Definition

In this user manual, servo motor rotation direction definition as below: By facing with the motor shaft, If the servo motor rotate with counter clockwise, it is defined as Forward rotating; If the servo motor rotate with clockwise is defined as reverse rotating.

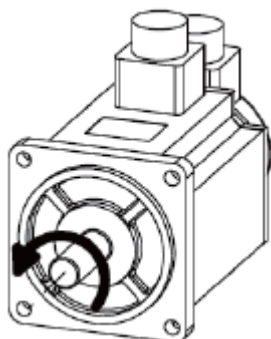

Forward rotating
Counter clockwise (CCW)

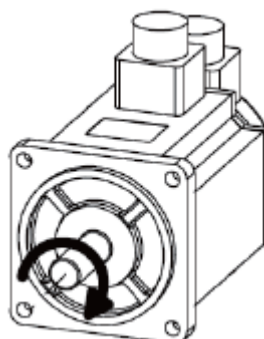

Reverse rotating
Clockwise (CW)

2.5 Basic Wiring Diagram

2.5.1 Servo Motor & Drive Wiring Diagram

SDV3-2S0.4G~2S0.75G

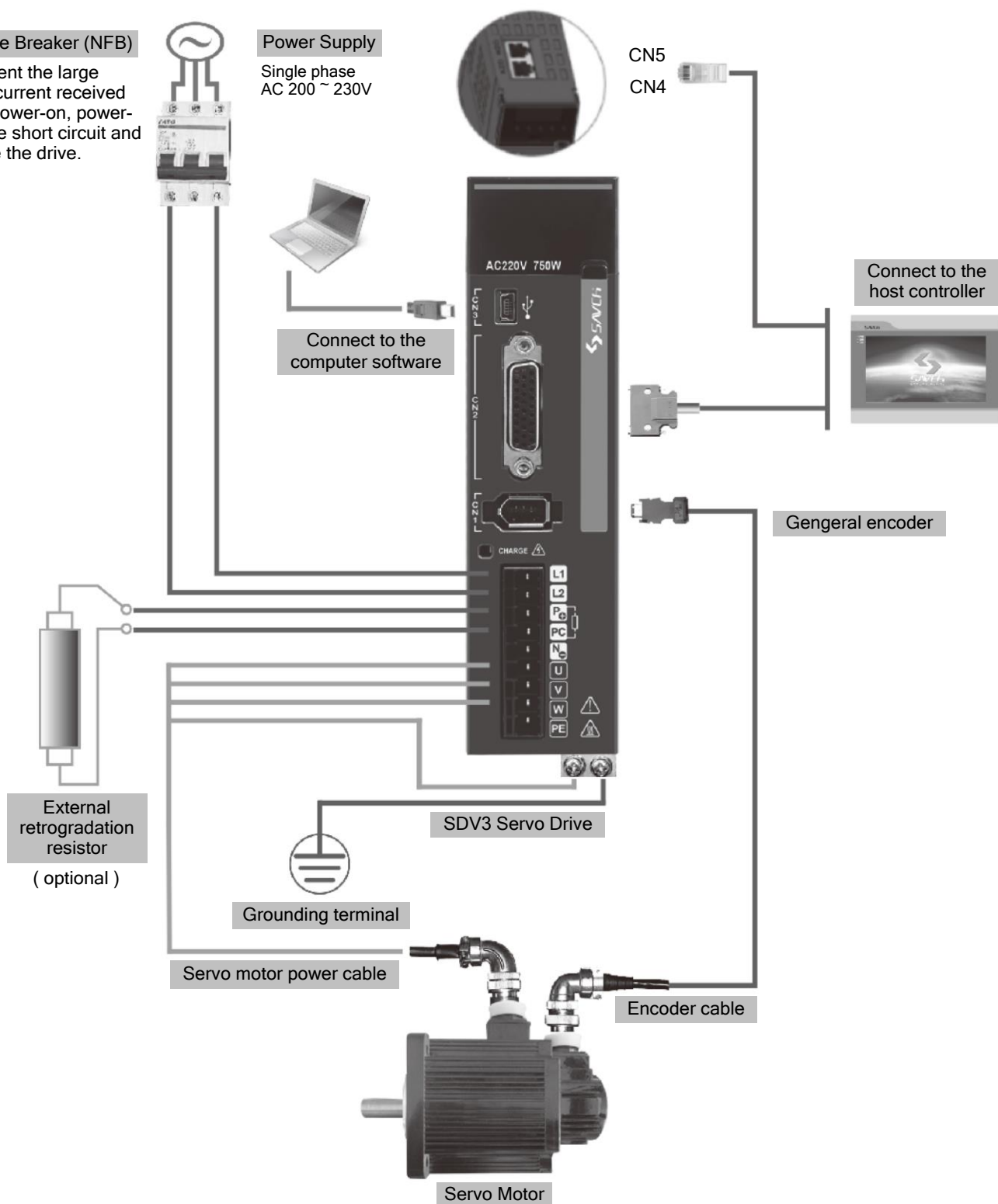

Installation Notes:

1. Check the L1,L2 power and connecting wire.
2. Check the servo motor output U, V, W terminal phase wires (Unable to run when the connection is wrong).
3. External connected regeneration resistor is the selective spare, adopt according to the actual needs.
4. CHARGE indicator is on means that the power is on. When the Power is turned off, there is still left with electric in the main-circuit, so the cable should be removed only when all the indicators are off.

SDV3-2S1.0G~1.5G/4T0.75G~2.0G

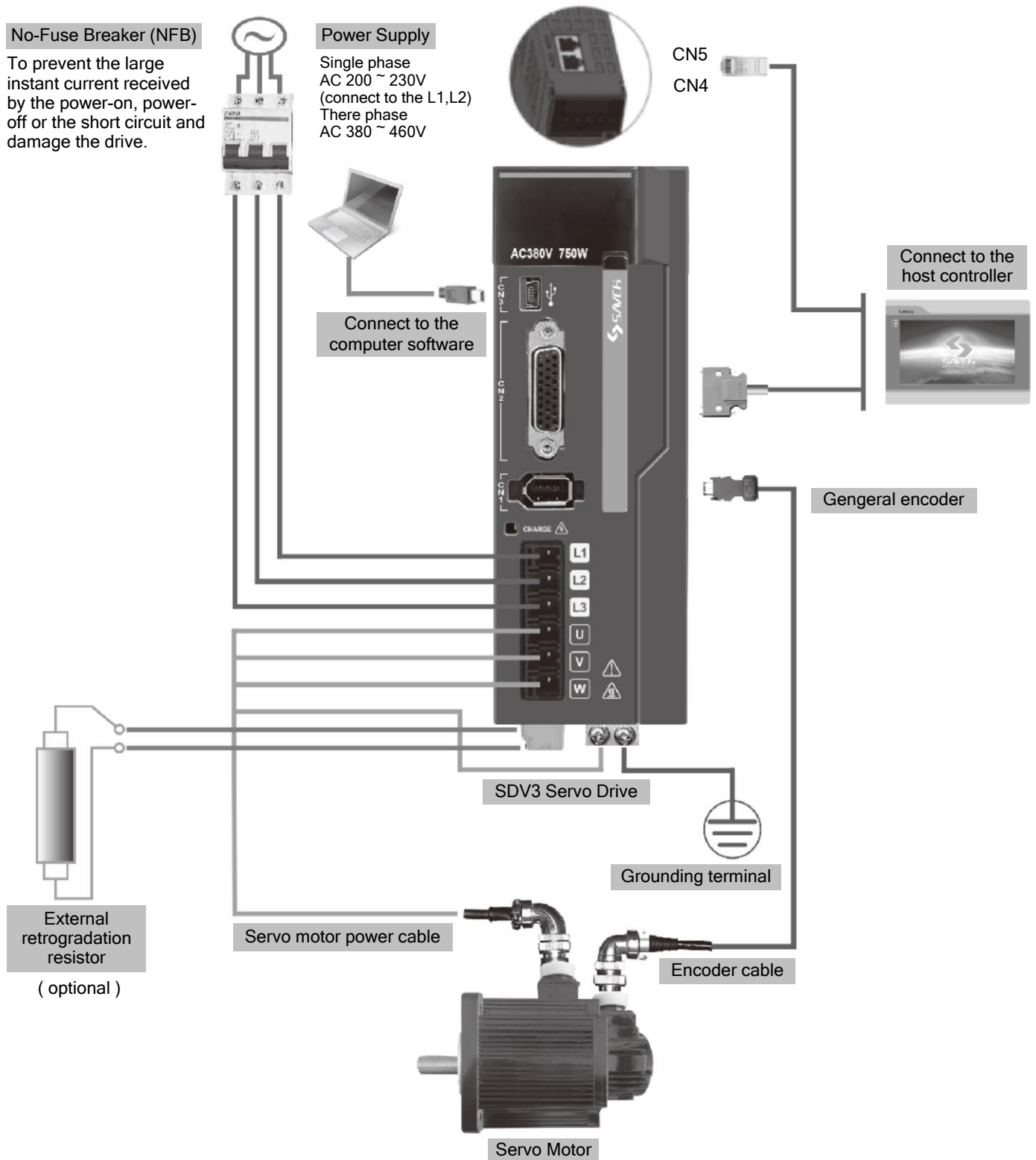

Installation Notes:

1. Check the L1,L2,L3 power and connecting wire.
2. Check the servo motor output U, V, W terminal phase wires (Unable to run when the connection is wrong).
3. External connected regeneration resistor is the selective spare, adopt according to the actual needs.
4. CHARGE indicator is on means that the power is on. When the Power is turned off, there is still left with electric in the main-circuit, so the cable should be removed only when all the indicators are off.

2.5.2 Wiring Instructions

Wiring Precautions:

- Please perform the wiring with the shortest length, the length of the reference cable should be within 3m and encoder cable is within 15m.
- Please perform the wiring according to the standard wiring diagram and the cable should not be connected to the signal which is not assigned.
- The phase sequence of the servo motor drive output terminal U, V, W must be corresponded to that of the servo motor respectively, otherwise, it may cause servo motor stop or out of control.
- The method of exchanging the output terminal U, V, W to make the servo motor reversible does not work, which is completely different with that of the synchronous servo motor, please do not use it.
- Perform ground wires, the ground resistance is 100Ω or below and single ground. If the insulation state between the servo motor and machine is required, please make the servo motor ground wire.
- The direction of the diode for absorbing on the output signal relay must be connected correctly, otherwise, it may cause fault and disable the output signal.
- In order to avoid the error action due to the noise, please add the insulation transformer and noise filter to the power.
- Please do not install the capacitor, overvoltage absorber and noise filter to the servo motor drive output.
- Please wire the cable (power line, servo motor line and strong circuit) and the signal cable with 30m or above and do not put into the same wiring instrumentation to avoid the interference causing the error action.
- Please install the non-fuse circuit breaker to cut off the Power when the servo motor drive fault occurs.
- Normally, fixing the regenerate braking unit is unnecessary, if any requirement, please contact with the manufacturer or distributor.

2.5.3 Example for Main Circuit /Control Circuit Power

⚠ CAUTION

- 1.The input Power stated by servo motor drive should be used(voltage level and frequency)
- 2.Wrong wiring of U, V, W will lead that the servo motor can not work normally, so please carry out the wiring correctly!

a.Single-phase 220V

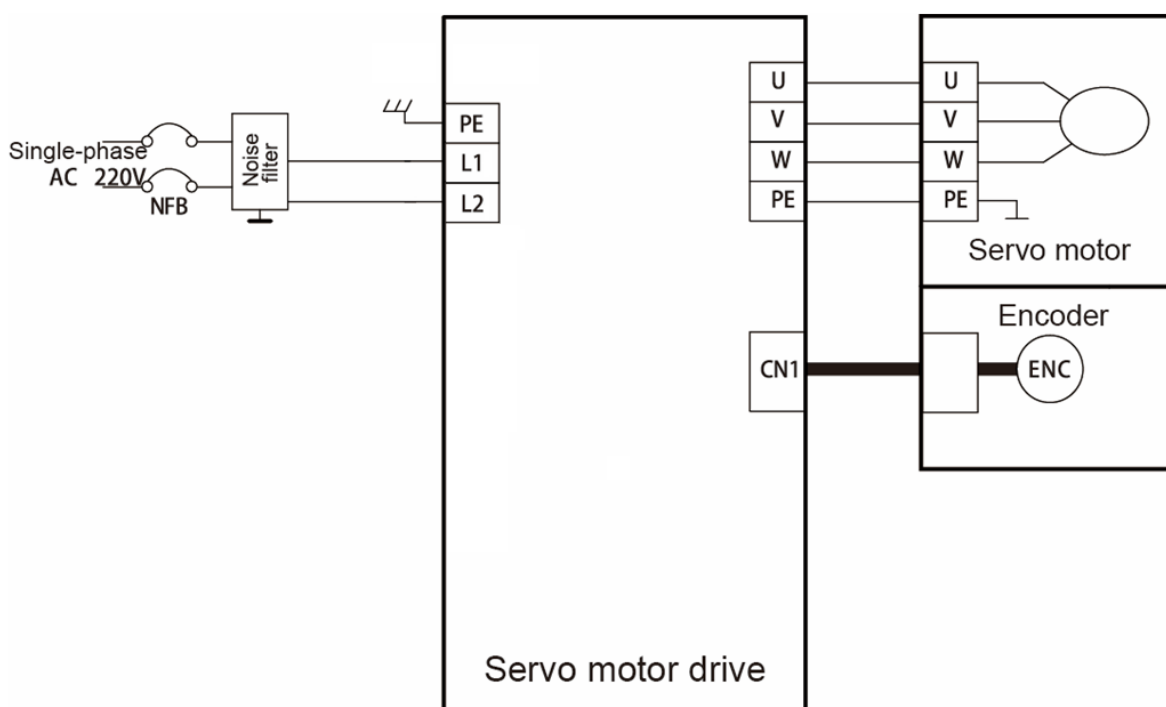

b. Three-phase 380V

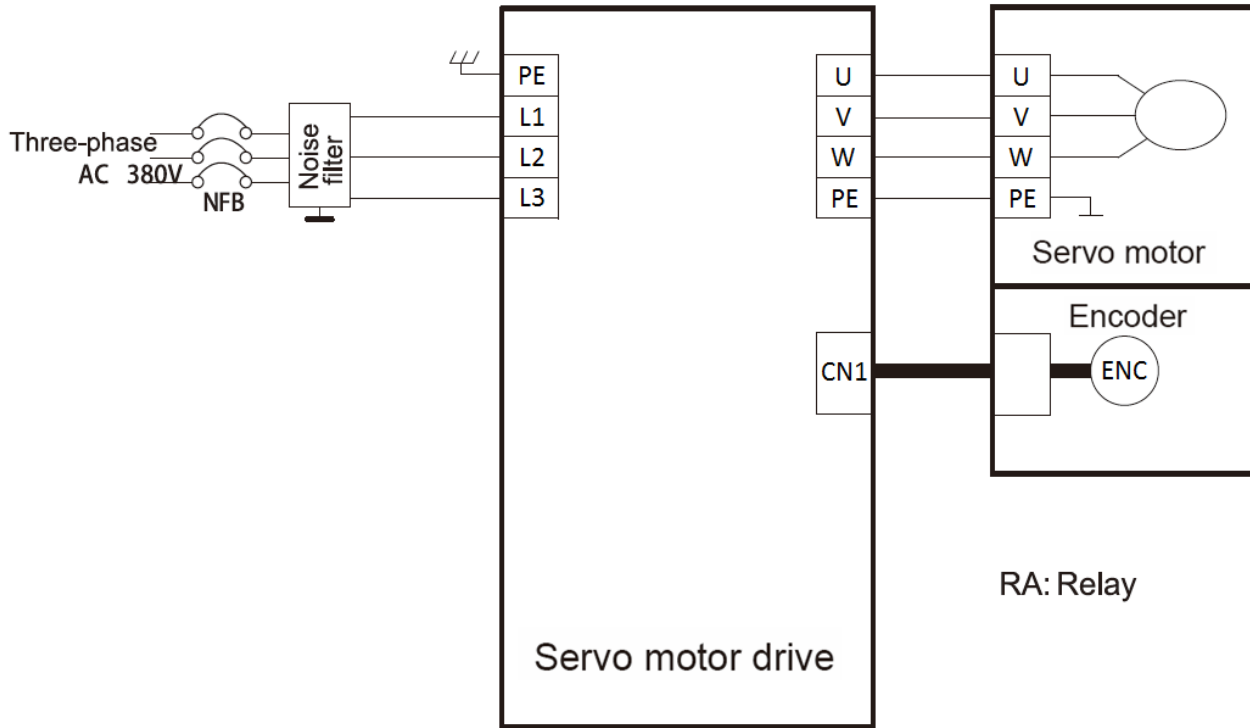

2.6 External Dimensions

2.6.1 Front View

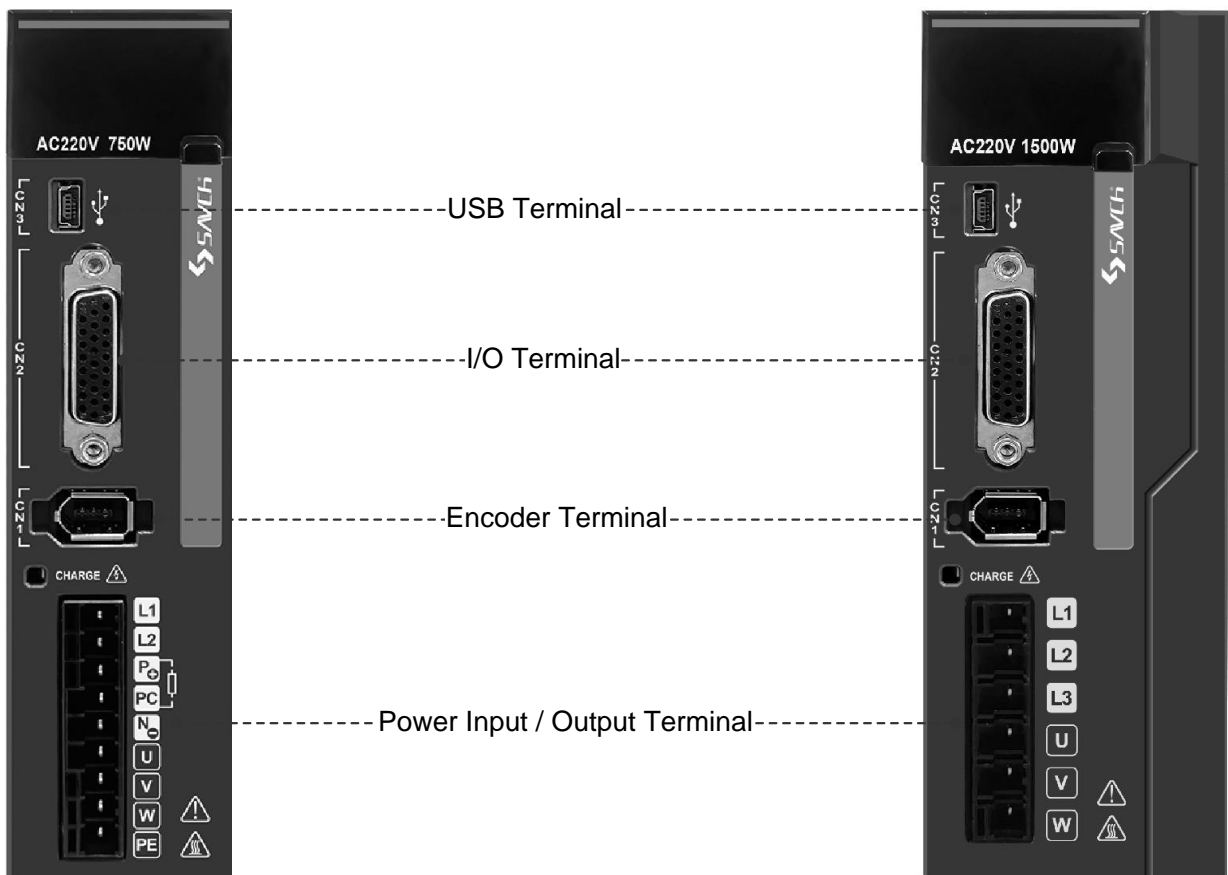

2.6.2 Servo Motor Drive Dimension

Size 1

Unit:mm

SDV3-2S0.4G~2S0.75G

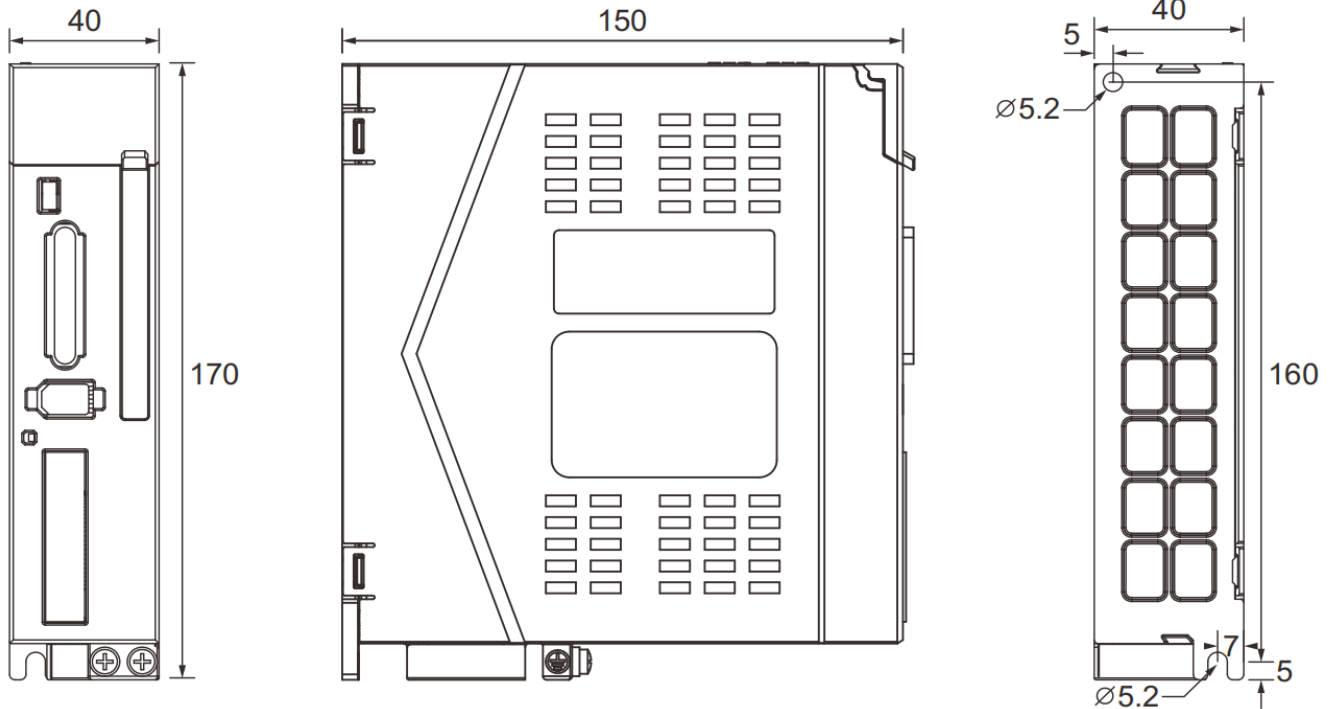

Size 2

Unit:mm

SDV3-2S1.0G~1.5G
SDV3-4T0.75G~2.0G

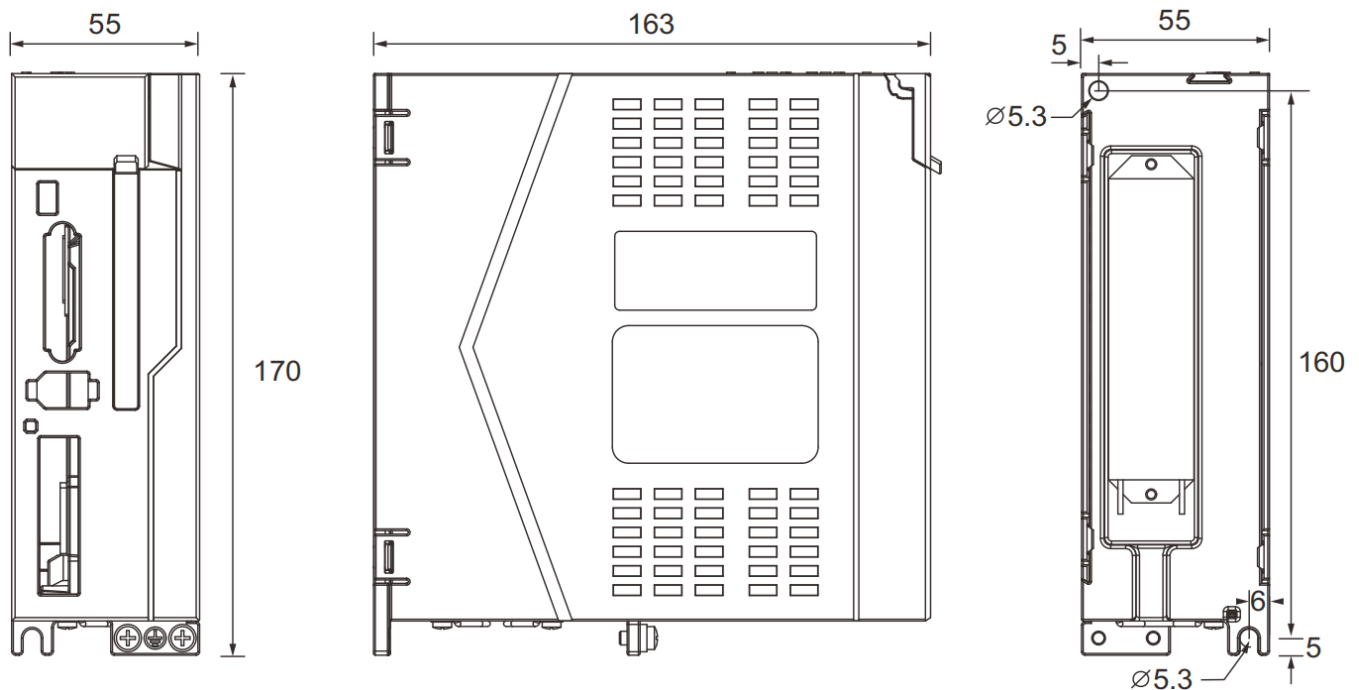

2.7 Basic Wiring Diagram Under Different Control Modes

2.7.1 Position Control Mode

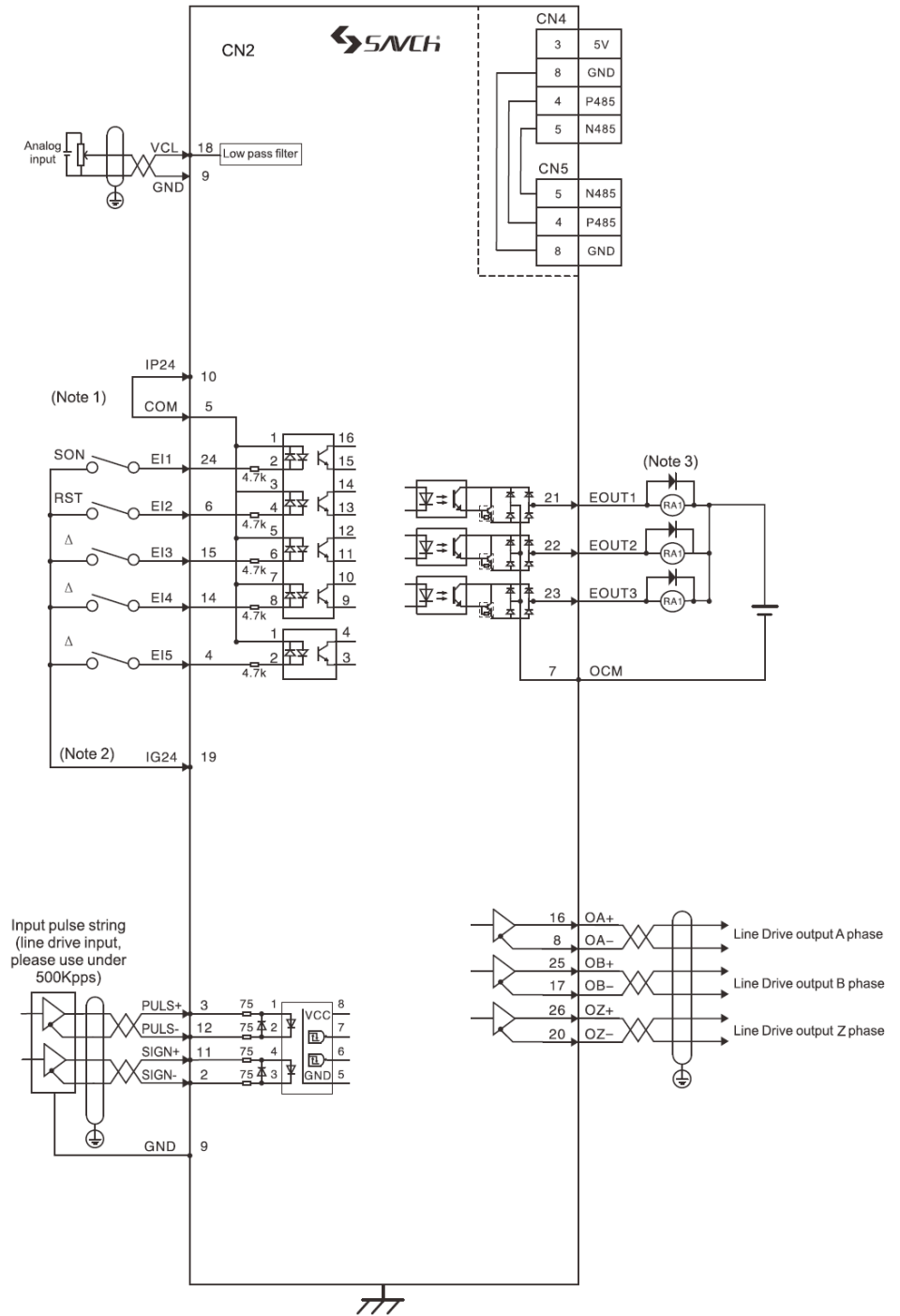
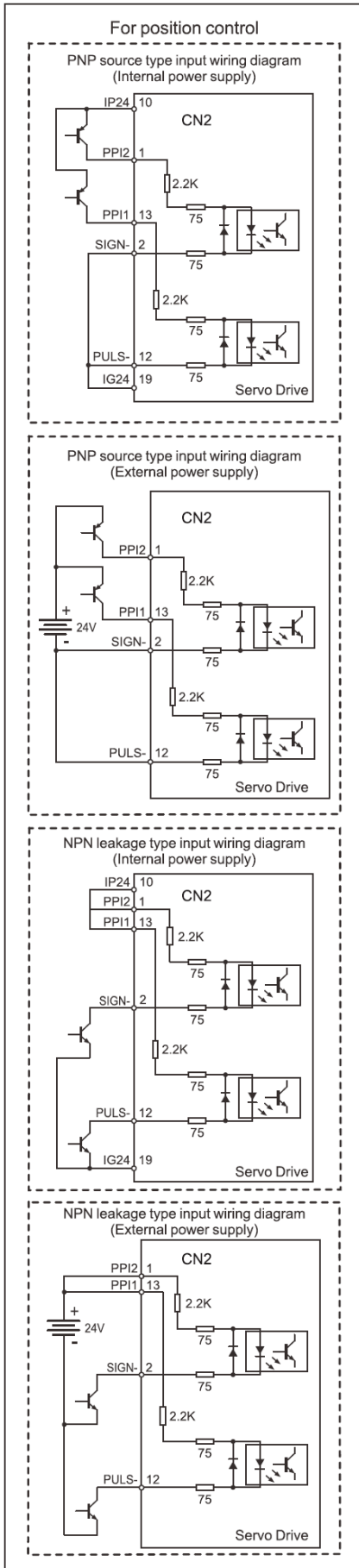

Notes 1:When the external power are adopted, do not connect the COM with IP24,external power supply 24V connected to COM.

Notes 2:The EI input terminal that is marked Δ indicates that the default function is not defined, user can set the required function according to the parameter of Chapter 6.

Notes 3:The diode installation direction could not be connected by the wrong way, max working voltage 24V, max output current 50mA; the current value of external relay ring should be lower than 80mA. When the current value is greater than 80mA, the power should be supplied externally.

2.7.2 Speed Control Mode

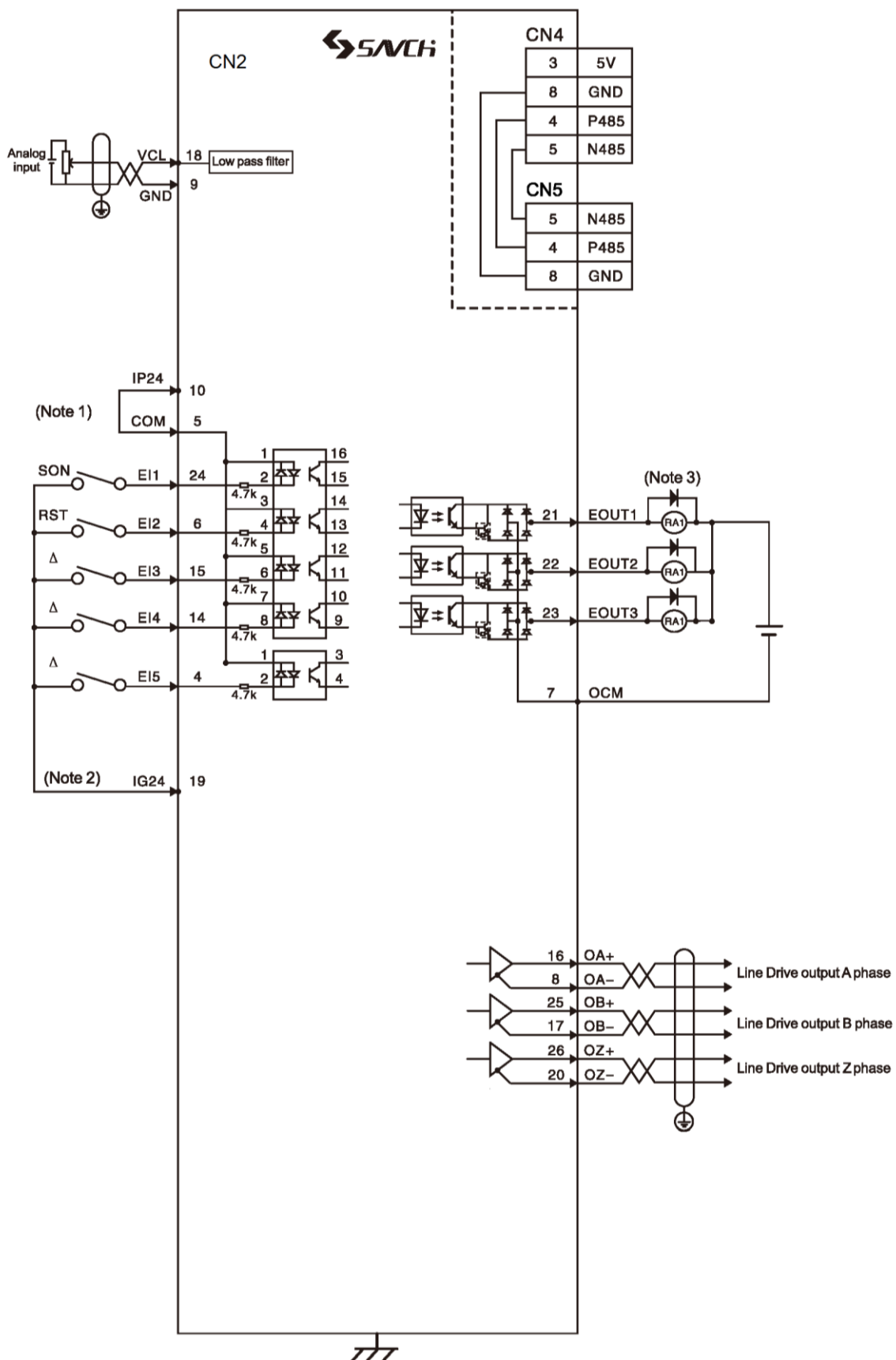

Notes 1: When the external power are adopted, do not connect the COM with IP24,external power supply 24V connected to COM.

Notes 2:The EI input terminal that is marked Δ indicates that the default function is not defined, user can set the required function according to the parameter of Chapter 6.

Notes 3: The diode installation direction could not be connected by the wrong way, max working voltage 24V, max output current 50mA; the current value of external relay ring should be lower than 80mA. When the current value is greater than 80mA, the power should be supplied externally.

2.7.3 Torque Control Mode

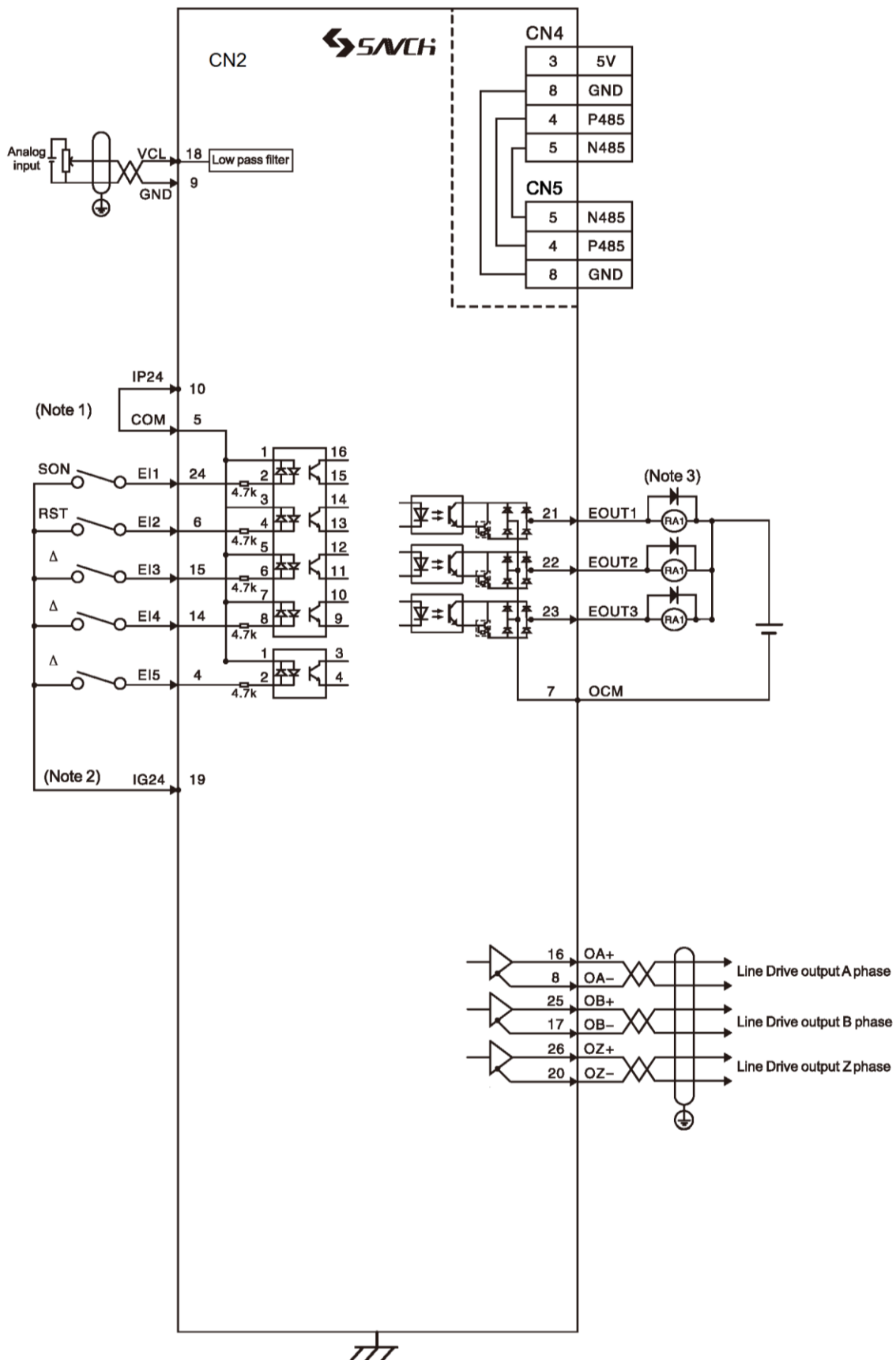

Notes 1: When the external power are adopted, do not connect the COM with IP24, external power supply 24V connected to COM.

Notes 2: The EI input terminal that is marked Δ indicates that the default function is not defined, user can set the required function according to the parameter of Chapter 6.

Notes 3: The diode installation direction could not be connected by the wrong way, max working voltage 24V, max output current 50mA; the current value of external relay ring should be lower than 80mA. When the current value is greater than 80mA, the power should be supplied externally.

2.8 Interfaces

2.8.1 Power Terminal

SDV3 Series main circuit terminal

Terminal mark	Name of signal	Function
L1	Main circuit power supply	Connect to external AC power. Single phase AC220V -15%~+10% 50/60Hz Three phase AC380V -15%~+10% 50/60Hz
L2		
L3		
U	Servo motor output	Connect with servo motor U、V、W.
V		
W		
P+	DC bus positive terminal	When using an external regenerative resistor, a regenerative resistor is added between the PC and P+ terminals.
PC	Regenerative resistor terminal	
N-	DC bus negative terminal	For common DC bus applications, connect P+ and N- terminals
PE	System protection grounding	Grounding terminal

⚠ CAUTION

1. The input Power stated by servo motor drive should be used (voltage level and frequency).
2. Wrong wiring of U, V, W will lead that the servo motor can not work normally, so please carry out the wiring correctly!

2.8.2 Input/Output Terminal CN2 (26 cores)

Shortened form for control mode:

P stands for position control mode;

S stands for speed control mode;

T stands for torque control mode;

Communication plugs Layout:

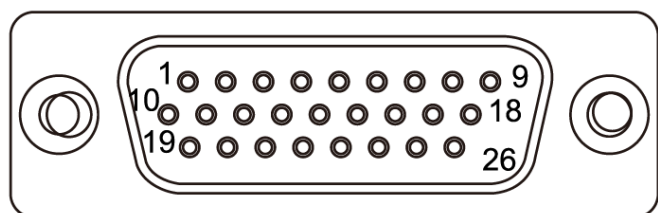
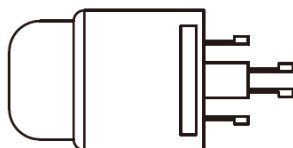

Front

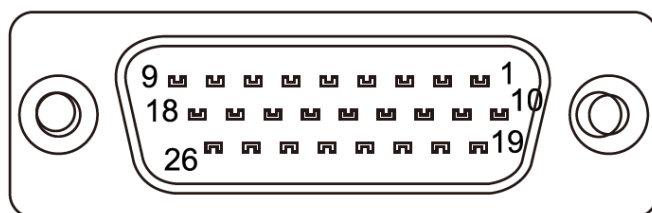

Back

Name of signal		Pin.No	Function		Control mode
Digital input	EI1	EI Input terminal 1	24	EI input terminal (corresponding sink/source signal) input command signal terminal to servo motor drive. DC12 [V]~24 [V]/8 [mA](each point) Optocoupler Insulated Common port is COM terminal When the input is interrupt, detection of hardware filter is delayed to 0.1 [ms]. Note: Interrupt input can only be assigned to EI5	P.S.T
	EI2	EI Input terminal 2	6		
	EI3	EI Input terminal 3	15		
	EI4	EI Input terminal 4	14		
	EI5	EI Input terminal 5	4		
	COM	Input common port	5		
Digital output	EOUT1	EOUT output terminal1	21	EOUT output terminal (corresponding sink /source signal) from the signal output terminal of servo motor drive. Max DC24 [V]/50 [mA]. Optocoupler Insulated Common port is COM terminal	P.S.T
	EOUT2	EOUT output terminal2	22		
	EOUT3	EOUT output terminal3	23		
	OCM	Output common port	7		
Position pulse command input	PULS+	Low speed position command input 1	3	Low speed external position pulse command input terminal	P.S
	PULS-		12		
	SIGN+	Low speed position command input 2	11		
	SIGN-		2		
	PPI1	PULS Power supply input	13	External position command power supply input.	
	PPI2	SIGN Power supply input	1		
Encoder signal output	OA+	A-Phase signal of encoder	16	Encoder A-phase pulse differential output	P.S.T
	OA-		8		
	OB+	B-phase signal of encoder	25	Encoder B-phase differential output	
	OB-		17		
	OZ+	Z-phase signal of encoder	26	Encoder Z-phase differential output	
	OZ-		20		
Analog signal	VCL	Analog command	18	External analog signal input range: -10V to +10V	P.S.T
Power	IP24	Internal isolation power+24V	10	Internal isolation power +24V output	P.S.T
	IG24	Internal isolation power 24V grounding	19	Internal isolation power +24V grounding	
	GND	Internal GND	9	Internal GND	

2.8.3 Encoder Feedback Signal Input Terminal CN1 (6 cores)

CN1

Pin.No	Name of signal	Function Code	Servo motor side connector signal		Pin function
			General connector	Aviation connector	
5	The encoder serial data positive	SD+	5	H	The encoder serial data output to drive by the end of the servo motor
6	The encoder serial data negative	SD-	6	D	
1	Power output positive	+5E	1	B	When the power of the encoder is 5V (provided by servo motor drive) and cable length is more than 20m, please use the 2 power wires for each one to avoid encoder voltage to decrease. If the cable length is more than 30m, please contact with the supplier.
2	Power output negative	GND	2	I	
shell	Shell PE	FG	9	F	Shielded network cable

2.8.4 Communication Interface CN4 (8 cores RJ45)

CN4

Pin.No	Name of signal	Function Code	Pin function
4	485 communication data positive	485P	485 communication differential signal
5	485 communication data negative	485N	
3	Power output positive	+5V	Power output, used for external setting of the communication
8	Power output negative	GND	
1,2,6,7	Not use	NC	Not use temporarily, do not connect

CN5

Pin.No	Name of signal	Function Code	Pin function
4	485 communication data positive	485P	485 communication differential signal
5	485 communication data negative	485N	
8	Common grounding	GND	Common grounding
1,2,3,6,7	Not use	NC	Not use temporarily, do not connect

The RJ45 pins are sorted as shown below:

CN4

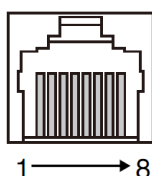

CN5



2.9 Input / Output Interface Type

2.9.1 Digital Input Interface

Digital input interface circuit can be operated by the switch, relay, open collector transistor circuit, optocoupler etc. The relay should be the low electric current, in order to avoid the faulty contacting. The external voltage range :DC12V~24V.

NPN crystal, common emitter SINK mode

·Internal power

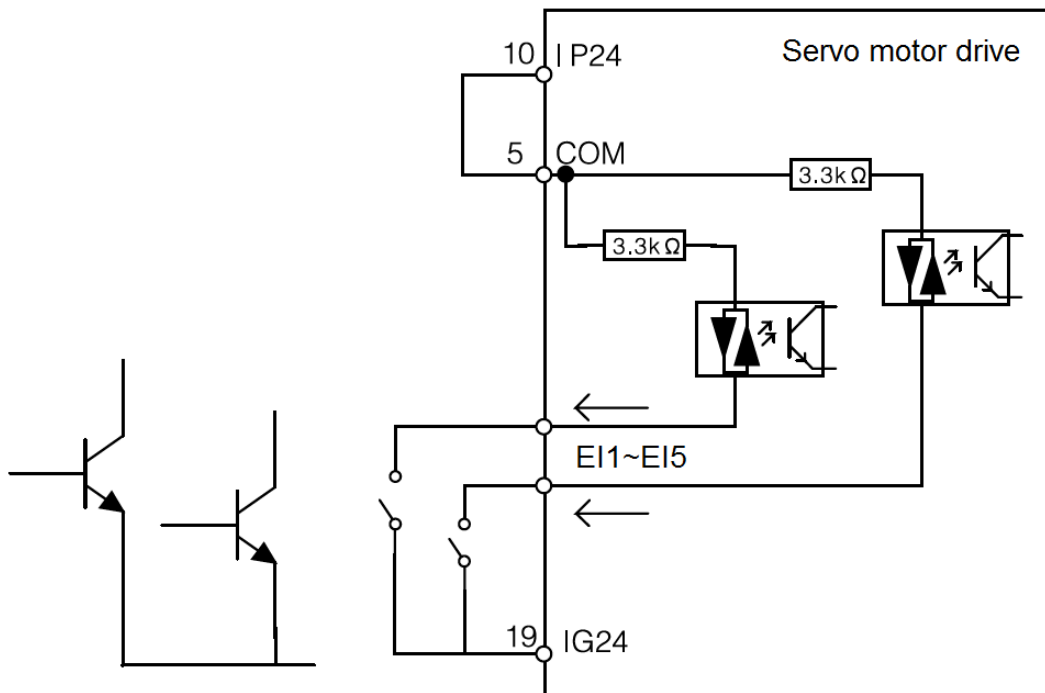

·External power

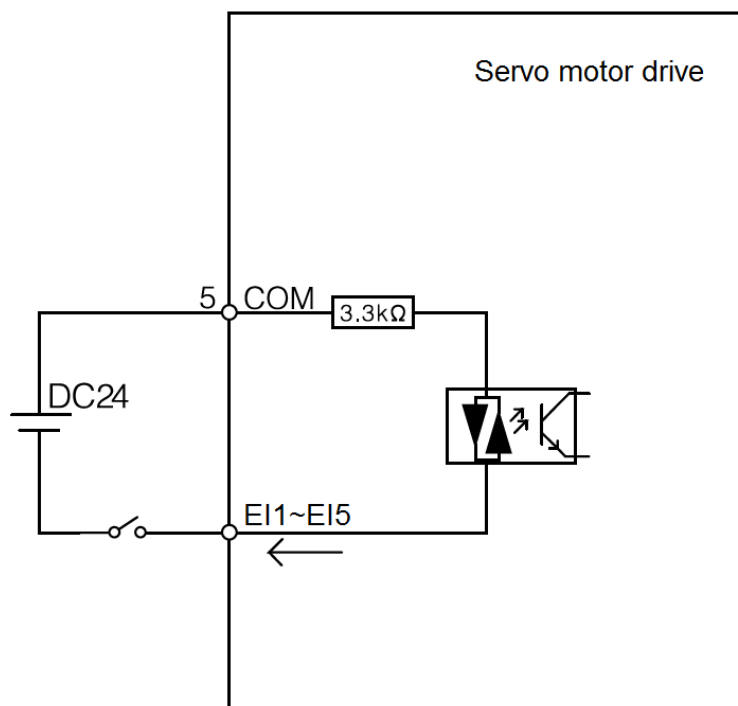

PNP crystal, common emitter SOURCE mode

Internal power

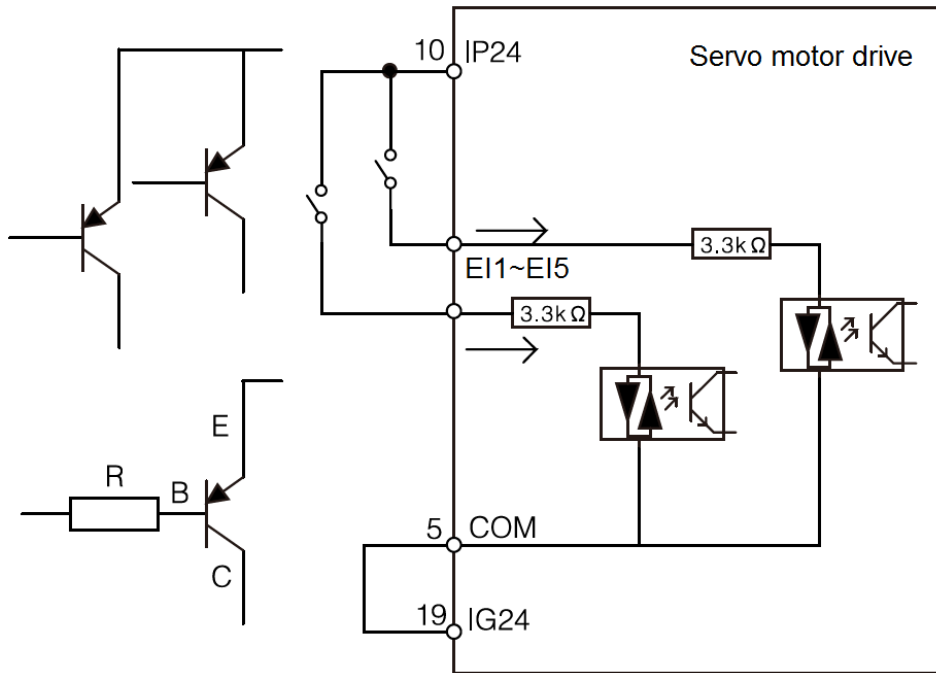

External power

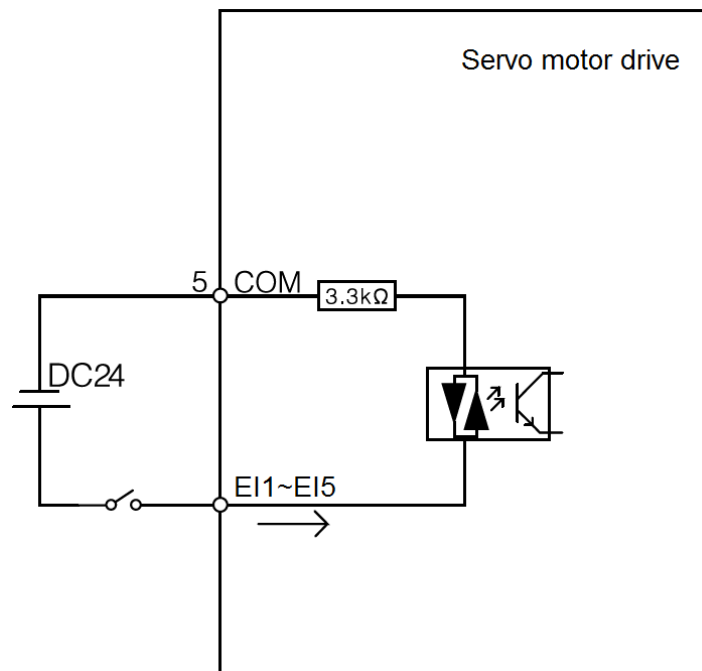

2.9.2 Digital Output Interface

Use the optocoupler for the output circuit, which can be connected with relay, optocoupler, the precaution as following:

- The external power should be provided by the user.
- The maximum of external voltage is 24V ,and the maximum output current is 50mA
- The diode should be used together when using the inductive character load such as the relay. Adverse polarity of the diode will case drive damage.
- When power is ON, there is around 1V of Dropout Voltage , which can not meet the TTL low level requirement, so it should not be connected with the TTL circuit directly

Relay (Fly-wheel diode must be required and the polarity of the diode should not be reverse rotating)

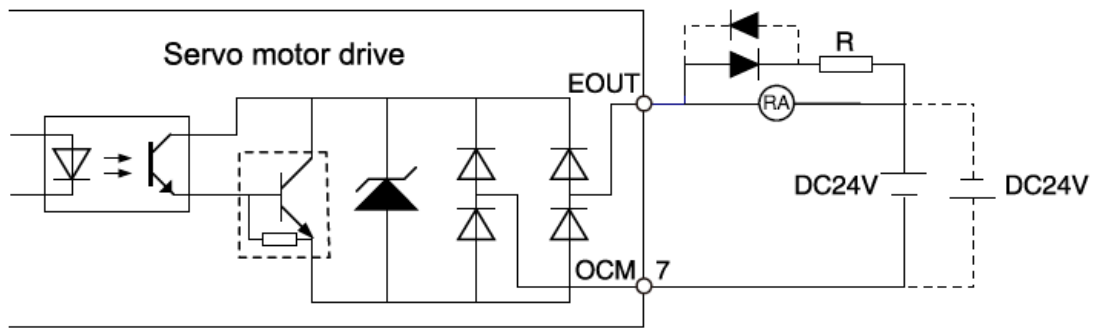

Optocoupler

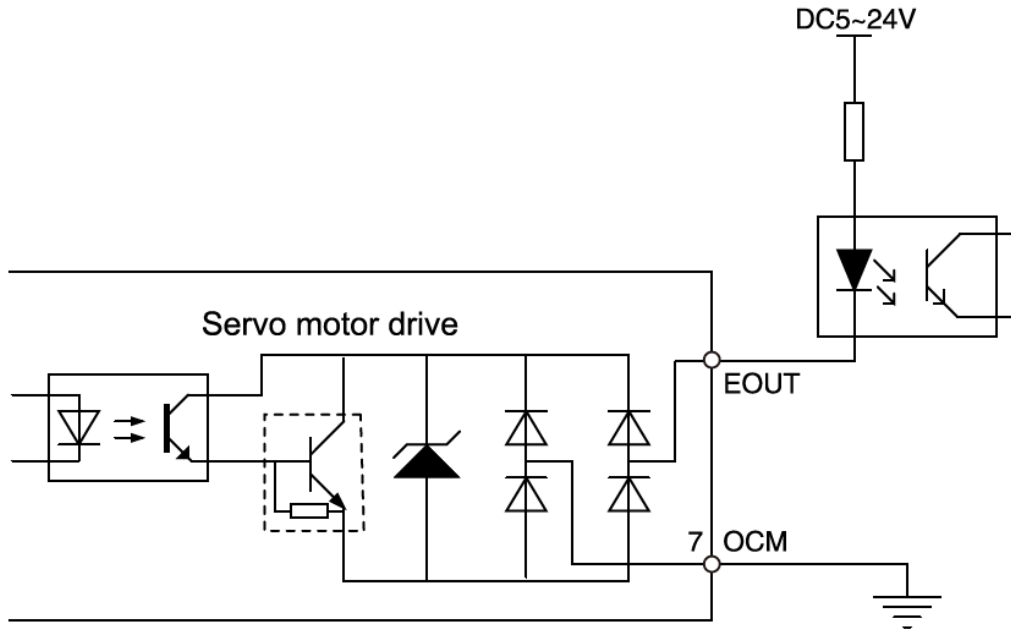

2.9.3 Position Pulse Input Interface

The Pulse input interface has two modes, Line drive and Open Collector drive.

Line drive

Here the Line drive is suggested. Twisted-pair is suitable for wiring.

Suggested driving current: (8~10 mA)

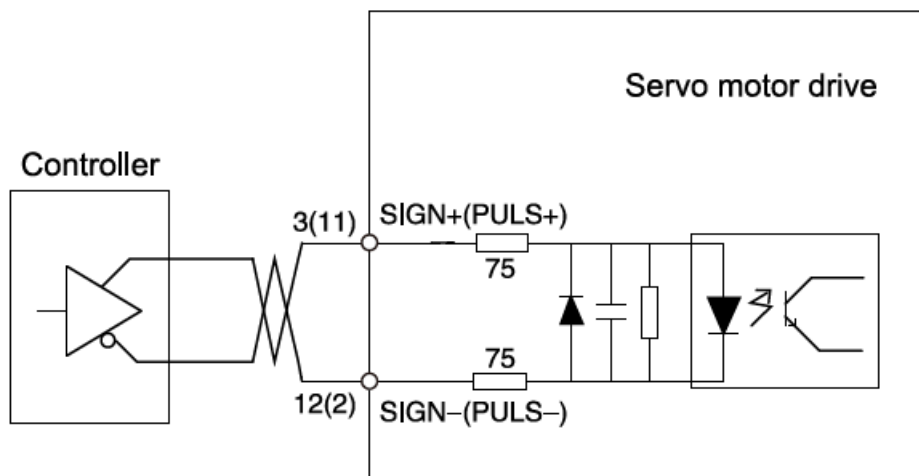

If the Line drive driving can not meet the equation $2.8V \leq (H \text{ level}) - (L \text{ level}) \leq 3.7V$, the servo unit input will be unstable. When the reference pulse is entered, it may cause the pulse missing.

When the reference signal is entered, it may select the reverse rotating value of the reference signal. The maximum pulse frequency is 500kHz. The Line drive driving will not easily be impacted by the external, so we suggest this connection.

•Open Collector drive (external power)

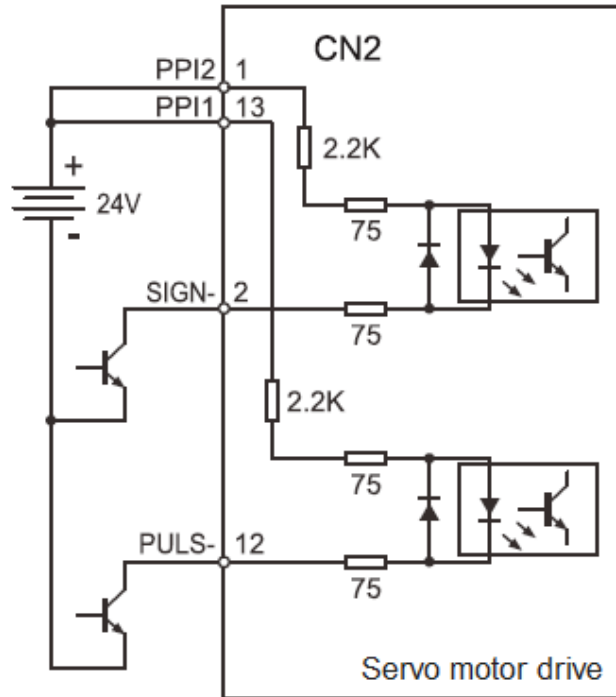

•Single drive (internal power)

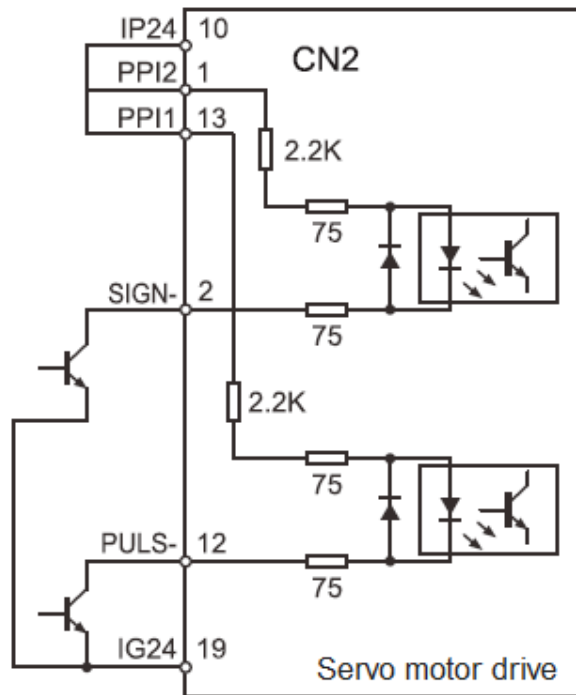

- When the input is TTL Line drive mode, there is no problem of power;
- When the input is open collector input mode, if internal 24V is adopted, IG24 is connected with the current outflow end of switch tube; if the external power is adopted, do not connect internal 24V with external power, and the Dropout Voltage of user's switch tube is requested to below 1V. If the voltage drop is higher than the value, an appropriate external pull-up resistance is needed to increase. External resistance selects $R = (5\sim 24V)/(8\sim 10mA)$, the power of the resistor is 1W. External pulse open collector drive mode, no matter it is internal or external supply, IG24 must be connected with the reference ground of control end or PLC etc.

Example: Using internal power supply, PPI1 (13 pin), PPI2 (1 pin) and IP24 (10 pin) of driver port CN2 are shorted, SIGN+ (11 pin) / PULS + (3 pin) are not wired, SIGN- (2 feet) / PULS-(12-pin)→ is connected to Y0/Y1 of PLC respectively, and the COM end of PLC is connected to IG24 (19-pin) of CN2.

● **Pulse input has three modes as the Motion table below:**

Pulse command form	Symbol	Forward rotating	Reverse rotating	Set value
Pulse symbol	SIGN PULS			P1.03= 000/003 Command pulse plus symbol SIGN symbol + PULS pulse
Forward rotating pulse Reverse rotating pulse	SIGN PULS			P1.03= 001/004 Forward rotating pulse / Reverse rotating pulse
A phase pulse B phase pulse	SIGN PULS			P1.03= 002/005 A/B Phase command pulse

2.9.4 Feedback Encoder Signal Outputs by Frequency Division

Encoder pulse signal can be output to a host controller by line drive output after it was set the required frequency. It has line drive output.

Received by line drive receiver

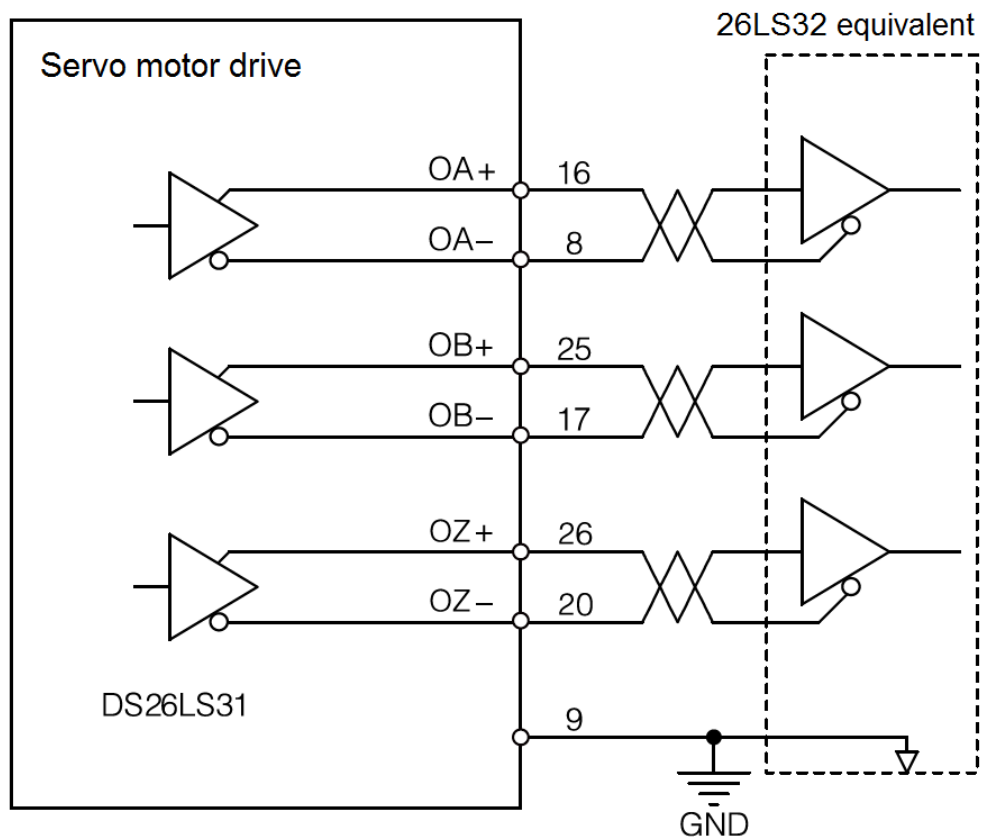

Please ensure the connection between the both sides of the signal grounding

Host controller use 26LS32 or equivalent as the receiver and must be connected to the terminal resistance from 220Ω~470Ω. The encoder output signal grounding of servo motor drive must be connected with that of the host controller. Otherwise, it may cause the received pulse error.

Received by optocoupler

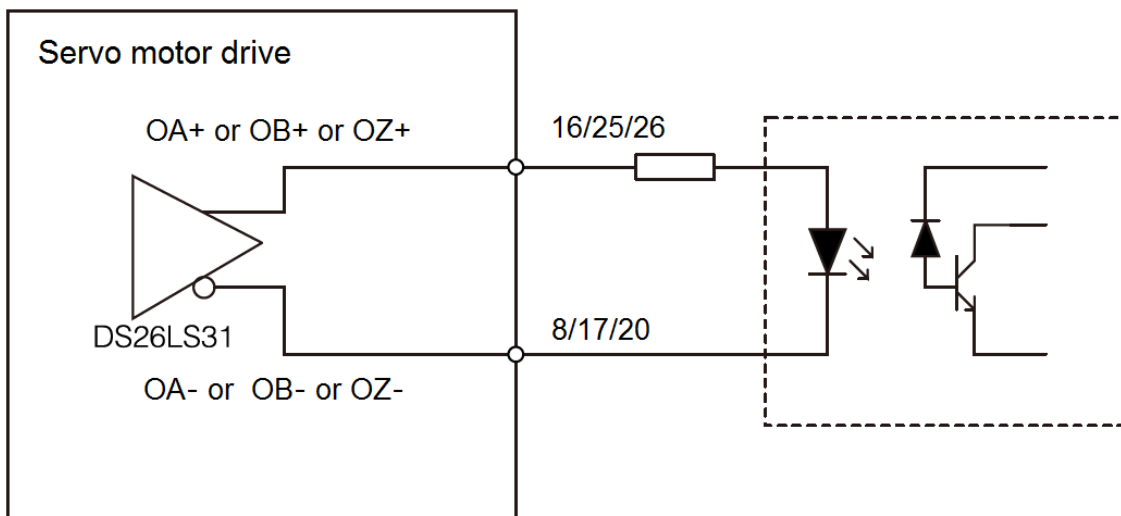

Host controller use high speed optocoupler (e.g. TLP115A) with 220Ω limited resistance.

2.9.5 Analog Command Input Interface

Speed reference/limit, torque reference/limit share an analog input, selected by parameter P3.43. The input voltage range is -10V to +10V and the input impedance is approximately 10kΩ.

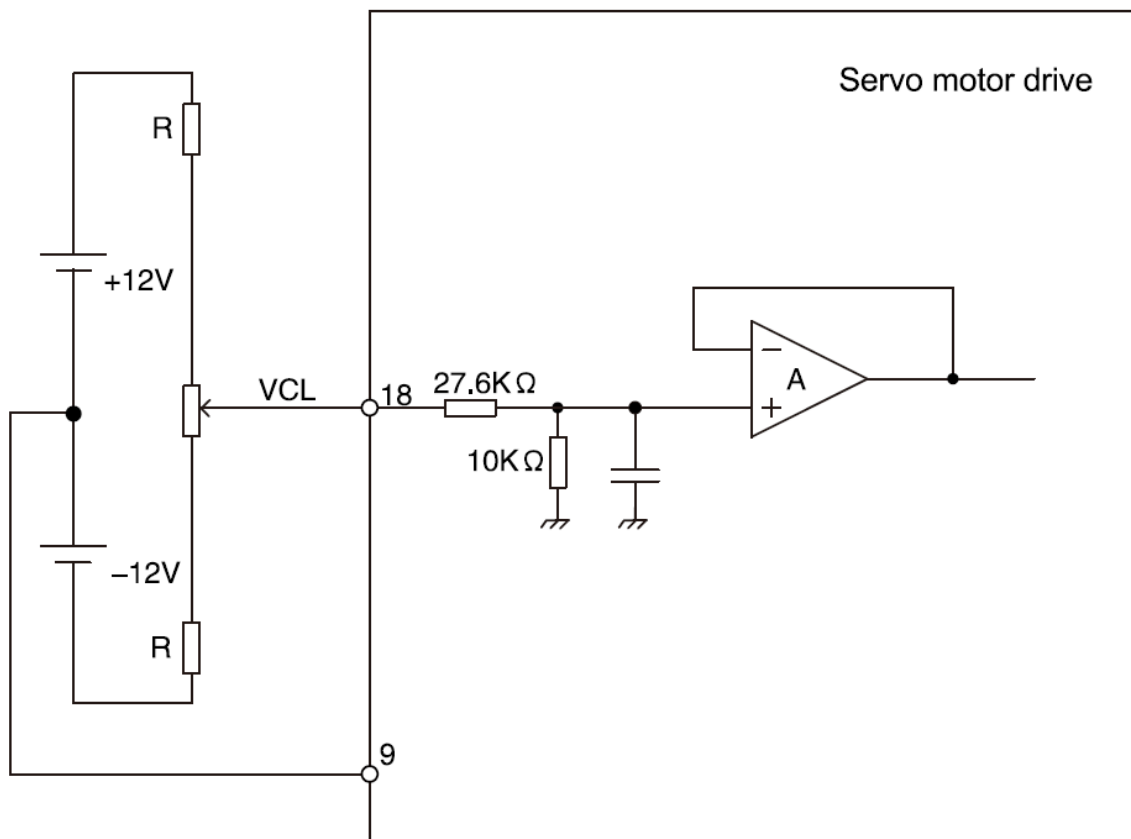







Analog command input

(Note: Bias is a normal phenomenon for the analog input, which could be compensated by the parameter.)

3 Description of Keypad Functions

3.1 Description of Keypad Functions

There are 5 LED digital tube displays and 5 keys on the keypad. The functions of the keypad are show in the following table:

































Key	Function description	SDV3 keypad
 MODE	Mode key Switch mode and return	
 ▲	Added key Increase No. or value	
 ▼	Reduced key Decrease No. or value	
 ►►	Shift key Right shift the setting bit	
 SET	Confirmed key Enter the next step or confirm the parameter data	

3.1.1 Mode

Nixie light display has 6 modes.

- Control status display mode: To display the controlling, running status of servo motor drive.
- Monitoring mode: The monitor each status and output/input signal of servo motor.
- Alarm mode: To indicate the current alarm and recodes.
- Parameter editing mode: To edit the parameter.
- Positioning data editing mode: To edit positioning data.
- Additional function mode: To use the key in the keypad to operate and run the servo motor.

7 sections of nixie light displays as below:

0	1	2	3	4	5	6	7	8	9	-
										
A	b	c	d	E	F	G	H	i	J	L
										
n	o	P	q	r	S	t	U	v	y	
										

3.1.2 Flash Display

In the display, sometimes, it is flash status.

Flash content and status as below:

Flash interval	Holding time	Status	Resetting action
0.5s cycle	continuous	Alarm is being output	Power- on again or alarm resetting
0.5s cycle	3s	Parameter is being checked	-
2s/1 time	continuous	In mode of command sequence test	Power- on again or after changing parameter P2.89=0, power-on again
2s/2 times	continuous	Notice of Power- on again	Power- on again

※The case of changing the parameter that is enable after power-on again

3.1.3 Display Packing of Up/Mid/Down Bit Data



3 times flash: upper bit



3 times flash: middle display



3 times flash: lower display

※ When the data content inside the drive exceeds four digits, one interface cannot display the complete data, so there is an upper/middle/lower position display.

※ Switching by the right shift key, each time the right shift key is pressed, the upper/middle/lower/bit is prompted first, and then the corresponding numerical content is displayed. For example, the display mode of the data 1234567890 is the upper display 12, the median display 3456, and the lower display 7890.

3.1.4 Mode Selection

Switch the modes by [MENU] key. There are 6 modes, shown as below:

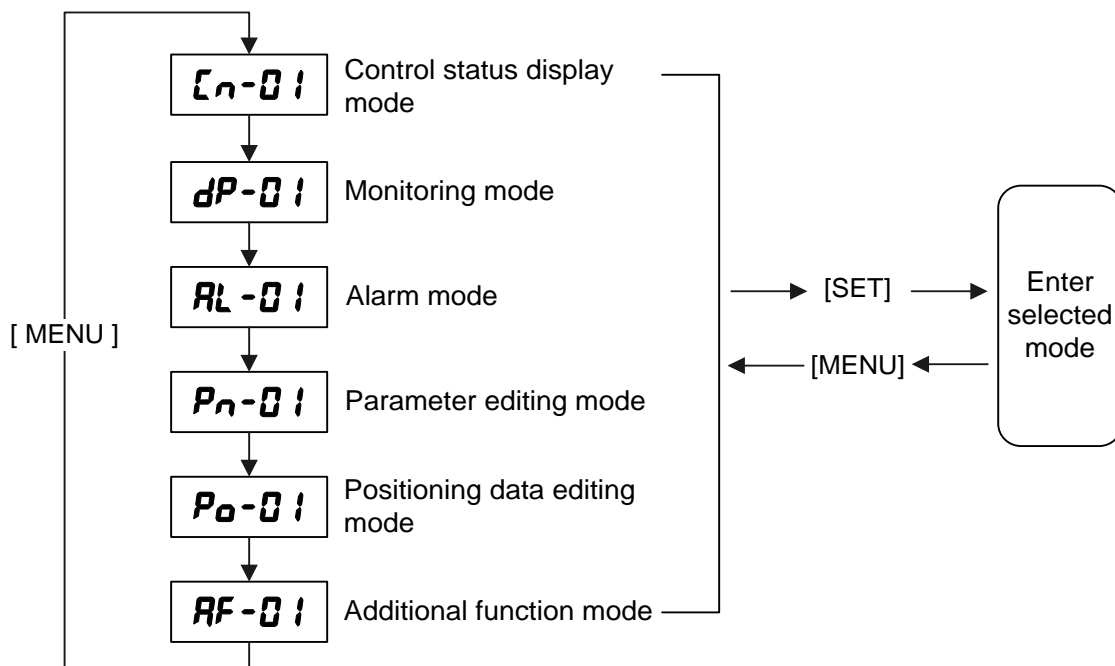

3.2 List of Descriptions for Functional Parameters

In the parameter editing mode and positioning data editing mode, the check and change of the setting value is available.

Mode	Sub-mode	Sub-mode selection	Display and setting example	Unit
Control status display mode	Action mode	Cn-01	PoF	
Monitoring mode	Feedback speed	dP-01	3000	rpm
	Command speed	dP-02	3000	rpm
	Command torque	dP-03	300	%
	Motor current	dP-04	0000	A
	Peak torque	dP-05	300	%
	Effective torque	dP-06	300	%
	△Feedback position	dP-07	99	unit
	△Command position	dP-08	09	unit
	△Position deviation	dP-09	00	unit
	○Command pulse frequency	dP-10	1	kHz
	△Feedback cumulative pulse	dP-11	00	pulse
	△Command cumulative pulse	dP-12	00	pulse
	○LS-Z pulse	dP-13	104	pulse
	Load inertia ratio	dP-14	3000	
	DC link voltage(max)	dP-15	300	V
	DC link voltage(min)	dP-16	300	V
	VREF input voltage	dP-17	1000	V
	TREF input voltage	dP-18	1000	V
	○Input signal	dP-19	11	
	○Output signal	dP-20	11	
	OL thermal value	dP-21	001	%

Remarks:△: With a triangle label, the data has upper/middle/lower segments when viewed.

○: With a round label, the data has upper/lower sections when viewed.

Mode	Sub-mode	Sub-mode selection	Display and setting example
Alarm mode	Current alarm	AL-01	nonE
	Alarm history	AL-02	noD1
	Warning	AL-03	0000
Parameter editing mode	Parameter page 1	Pn-01	P101
	Parameter page 2	Pn-02	P201
	Parameter page 3	Pn-03	P301
	Parameter page 4	Pn-04	P401
Positioning data editing mode	Positioning data pages 1	Pa-01	noD1
Additional function mode	Manual operation	AF-01	uG
	Position preset	AF-02	PrSt
	Homing	AF-03	orG
	Auto-operation	AF-04	Aut
	Alarm reset	AF-05	ALrE
	Alarm history initialization	AF-06	AL.in
	Parameter initialization	AF-07	PR.in
	Positioning data initialization	AF-08	Pa.in
	Auto off-set adjustment	AF-09	RoFF
	Z-phase off-set adjustment	AF-10	ZoFF
	Auto-tuning gain	AF-11	AtEn
	Easy tuning	AF-12	SLr
	Mode operation	AF-13	PEr
	Sequence test mode	AF-14	SeqTS
	Teaching	AF-15	tEcH

3.3 Control Status Display Mode

Control status display mode means the servo motor drive's output signal and running status.

Press key [MENU] to display [Cn-01], press [SET] to display description.

Action mode

Means servo motor drive's output signal and running status

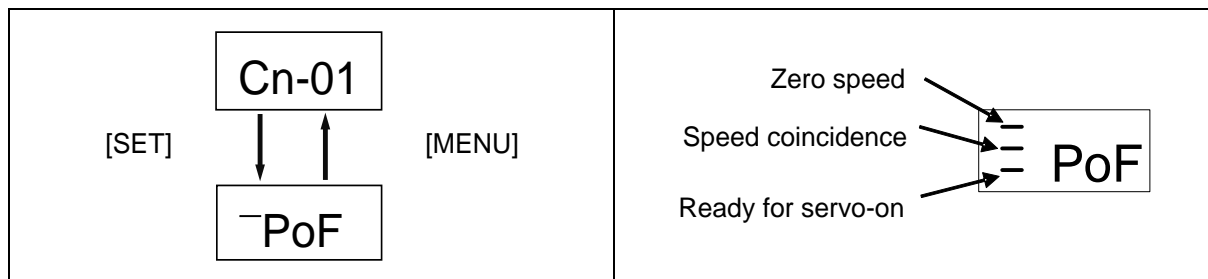

Display	Control mode	Name	Content	
$\bar{P}oF$	Position control	Servo OFF	No power to motor. No drive power in servo motor	
$\bar{P}on$		Servo ON	Servo motor is under rotatable operation	
$\bar{P}uG$		Manual operation	Being rotating is feed by manual	
$\bar{P}P_1$		Pulse operation	Pulse is being inputted	
$\bar{P}ARt$		Auto-operation	Being positioning operation	
$\bar{P}or$		Homing	Being homing	
$\bar{P}it$		Interrupt positioning	Being interrupt positioning	
$\bar{P}ot$		+OT	Overrun signal of the forward direction is being detected	
$\bar{P}ot$		-OT	Overrun signal of the reverse direction is being detected."P" and "-" display alternately	
$\bar{P}n0$		Zero speed stop	Input forced-to-stop signal to make it stop at zero speed.	
$\bar{P}Lu$		LV Status	Low voltage. For more detail information, please refer to the page regarding the under voltage	
$\bar{n}oF$		Speed control	Servo OFF	No power to motor. No drive power in servo motor
$\bar{n}on$			Servo ON	Servo motor is under rotatable operation
$\bar{n}uG$	Manual operation		Being rotating is feed by manual	
$\bar{n}ot$	+OT		Overrun signal of the forward direction is being detected	
$\bar{n}ot$	-OT		Overrun signal of the reverse direction is being detected.	
$\bar{n}n0$	Zero speed stop		Input forced-to-stop signal to let it stop at zero speed	
$\bar{n}Lu$	LV Status		Low voltage. For more detail information, please refer to the page regarding the under voltage	

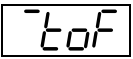
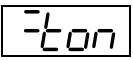
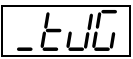
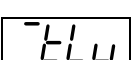
Display	Control mode	Name	Content
	Torque control	Servo OFF	No power to motor. No drive power in servo motor
		Servo ON	Servo motor is under rotatable operation
		Manual operation	Being rotating is feed by manual
		LV Status	Low voltage. For more detail information, please refer to the page regarding the under voltage

Tips: if the servo motor drive is power on, then display (action mode of control status display).

The display content can be changed when it is power on in parameter P2.77.

3.4 Monitor Mode

In the monitor mode, the servo motor rotation speed, cumulative input pulse and so on are displayed.

Press the [MODE] key until [dP-01] is displayed, and press [SET] key to display data.

dP-01: Feedback speed	dP-08: Command position	dP-15: DC link voltage (max.)
dP-02: Command speed	dP-09: Position deviation	dP-16: DC link voltage (min.)
dP-03: Command torque	dP-10: Command pulse frequency	dP-17: VREF input voltage
dP-04: Motor current	dP-11: Feedback cumulative pulse	dP-18: TREF input voltage
dP-05: Peak torque	dP-12: Command cumulative pulse	dP-19: Input signals
dP-06: Effective torque	dP-13: LS-Z pulse	dP-20: Output signals
dP-07: Feedback position	dP-14: Load inertia ratio	dP-21: OL thermal value

(1) Feedback speed (displayed digits: signed four digits)

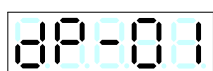

[ESC] ↑ ↓ [SET]

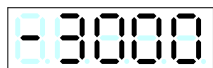

Current rotation speed of servo motor.

The correct value is displayed even if the load (mechanical system) rotates the motor.

The speed is displayed in r/min and a negative sign is attached for reverse rotation (clockwise rotation when viewed against the motor shaft). With a negative data.

(2) Command speed (displayed digits: signed four digits)

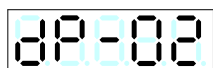

[ESC] ↑ ↓ [SET]

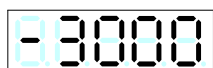

Current speed command issued to the servo motor. The command speed is given in a speed command voltage, multi-step speed, pulse or similar.

The speed is displayed in r/min and a negative sign is attached for reverse rotation (clockwise rotation when viewed against the motor shaft). With a negative data.

(3) Command torque (displayed digits: signed three digits)

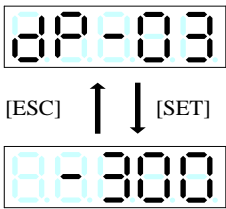

Average torque issued from the servo driver to the servo motor; the torque is displayed in percent to the rated torque. The range from 0% to the maximum torque is displayed in increments of 1. In case of a negative average torque, a negative sign is attached to the most significant digit.

(4) Motor current (displayed digits: signed three digits)

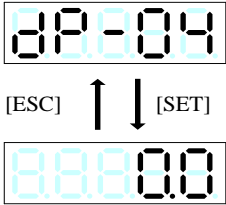

The current flowing in the servo motor.
The range from 0.0 [A] to (maximum current) is displayed on a scale of 0.1 [A].
When the motor current is negative, the negative sign is displayed in the fourth digit.

(5) Peak torque (displayed digits: signed three digits)

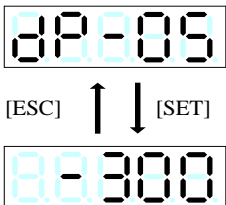

Peak torque value of the servo motor at every two seconds; the torque is displayed in percent to the rated torque. The range from 0% to the maximum torque is displayed in increments of 1. In case of a negative peak torque, a negative sign is attached to the most significant digit.

(6) Effective torque (displayed digits: signed three digits)

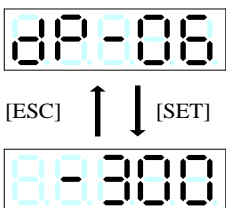

The load ratio of the servo motor; displayed in percent to the rated torque.
The range from 0% to the maximum torque is displayed in increments of 1.

(7) Feedback position (displayed digits: signed 10 digits)

The rotation amount of the servo motor is displayed in the unit amount after correction with an electronic gear. If the electronic gear is unused, the data indicates the exact rotation amount of the motor shaft encoder (131072 pulses/rev for the 17-bit serial encoder).

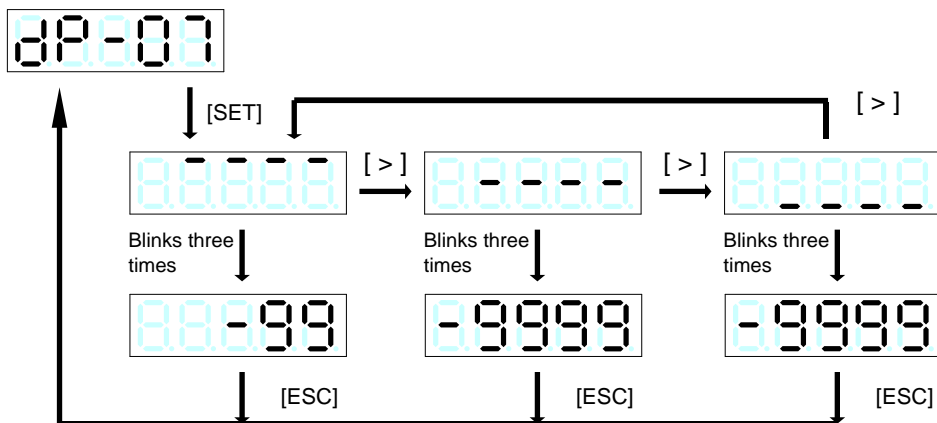

(8) Command position (displayed digits: signed 10 digits)

The position of the servo motor controlled by the servo driver is displayed in the unit amount after correction with an electronic gear. If the operation command is turned off and the load (mechanical system) rotates the motor after the target position is reached, the position is not correct.

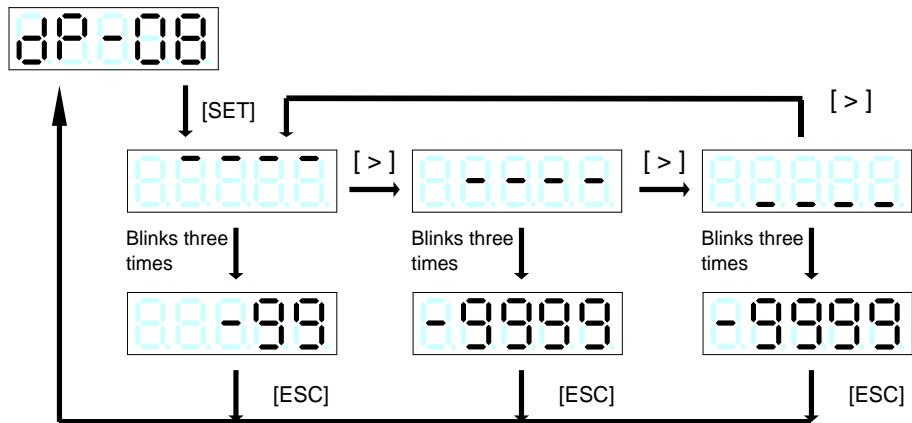

(9) Position deviation (displayed digits: signed 10 digits)

The difference between the command position and feedback position is displayed. The unit of deviation amount follows the deviation unit selected in P1.31.

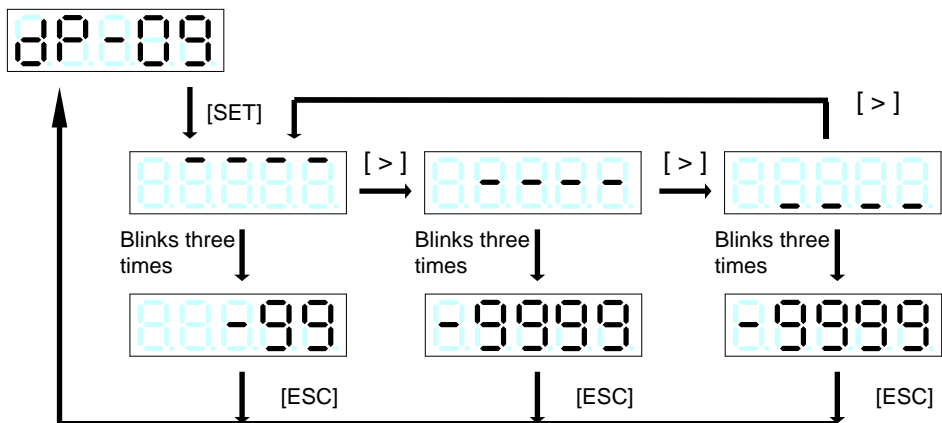

(10) Command pulse frequency (displayed digits: signed five digits)

The pulse frequency supplied to the pulse input terminal is displayed. The value is displayed in 0.1 kHz. The displaying range is from -4000.0 to 4000.0 kHz.

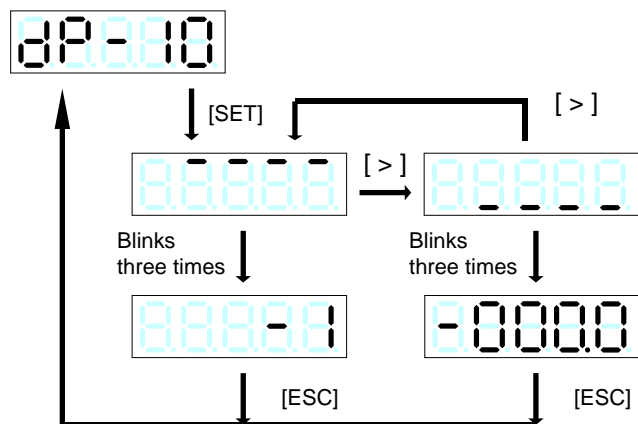

(11) Feedback cumulative pulse (displayed digits: signed 10 digits)

The cumulative pulses of servo motor rotation amount are displayed in encoder pulses (131072 pulses per revolution with 17-bit serial encoder). Reverse rotation decreases the cumulative value. Even if the load (mechanical system) rotates the motor, the correct value is displayed.

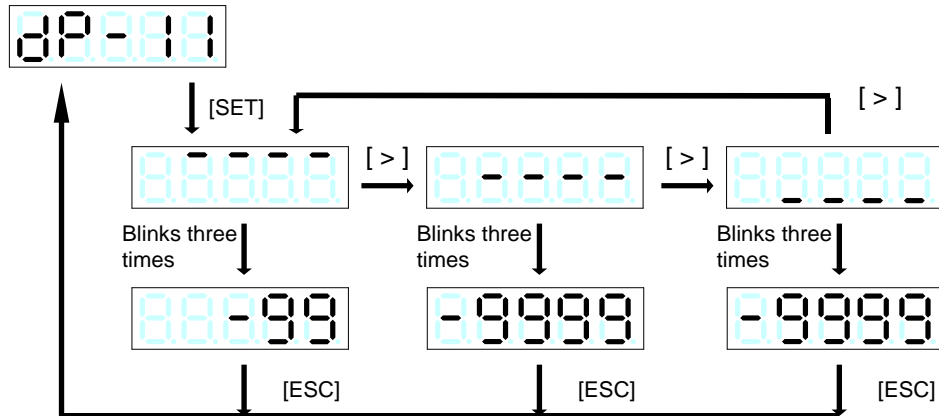

(12) Command cumulative pulse (displayed digits: signed 10 digits)

The number of pulses supplied to the pulse input terminal is displayed. The cumulative value increases upon forward direction pulses, while it decreases upon reverse direction pulses. With two signals at A/B phase pulse, each edge is counted (multiple of four). The count increases upon B-phase advance.

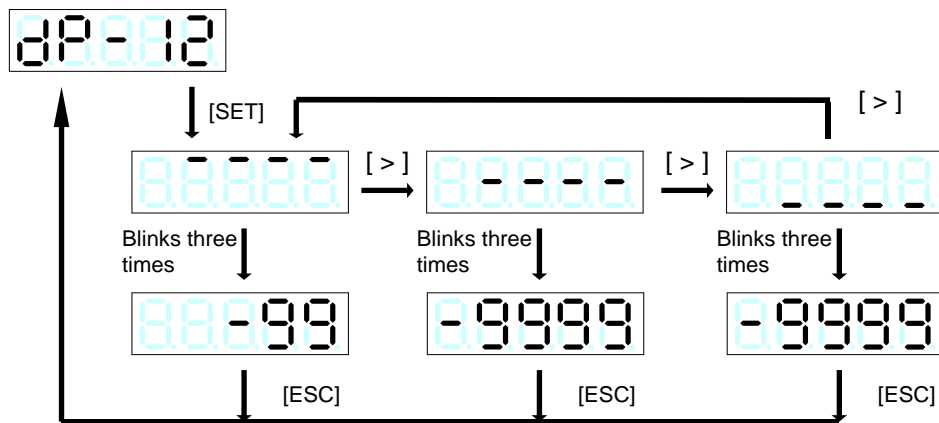

(13) LS-Z pulse (displayed digits: unsigned seven digits)

The number of pulses in a homing counted since the home position LS signal is turned off until the Z-phase of the encoder of the servo motor is detected is displayed. The indication is updated every time homing is performed. Because the value is in the homing direction, no negative sign is attached. Displayed only if the Z-phase is enabled.

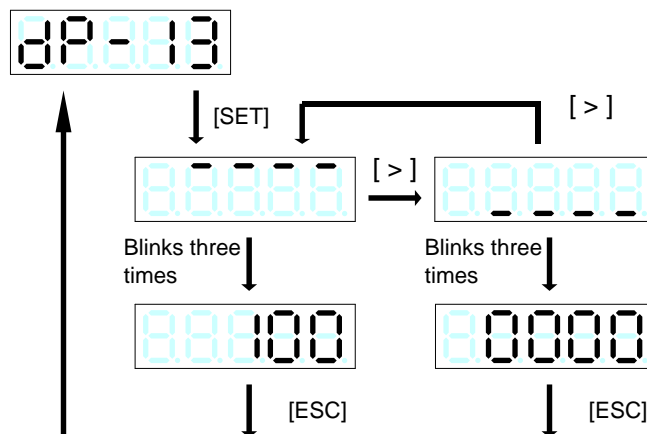

(14) Load inertia ratio (displayed digits: unsigned four digits)

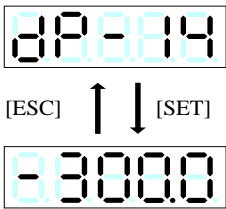

The load inertia ratio recognized by the servo driver without relations to parameter P1.13(tuning mode selection) is displayed. The value is displayed in a multiple (in 0.1 increments) to the inertia of the servo motor itself. The displaying range is from 0.0 to 300.0 times.

$$\text{(Load inertia ratio)} = \frac{\text{(Load inertia recognized by servo driver)}}{\text{(Inertia of servo motor itself)}}$$

(15) DC link voltage (max.) (Displayed digits: unsigned three digits)

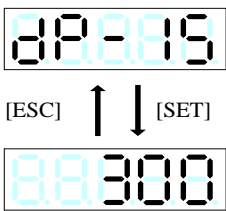

The DC link voltage (max.) of the servo driver at every two seconds is displayed. The displaying range is from 0 to 500V.

(16) DC link voltage (min.) (displayed digits: unsigned three digits)



The DC link voltage (min.) of the servo driver at every two seconds is displayed. The displaying range is from 0 to 500 V.

(17) VREF input voltage (displayed digits: signed four digits)



The input voltage of the analog input terminal [VREF] is displayed in 0.01 V. The negative sign indicates a negative voltage.

(18) TREF input voltage (displayed digits: signed four digits)

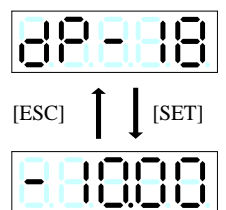

The input voltage of the analog input terminal [TREF] is displayed in 0.01 V. The negative sign indicates a negative voltage.

(19) Input signals

The ON/OFF status of sequence input signals supplied to the servo driver is displayed.

The corresponding LED lights up when the input signal is turned on.

While all the input signals are off, the display shows "nonE."

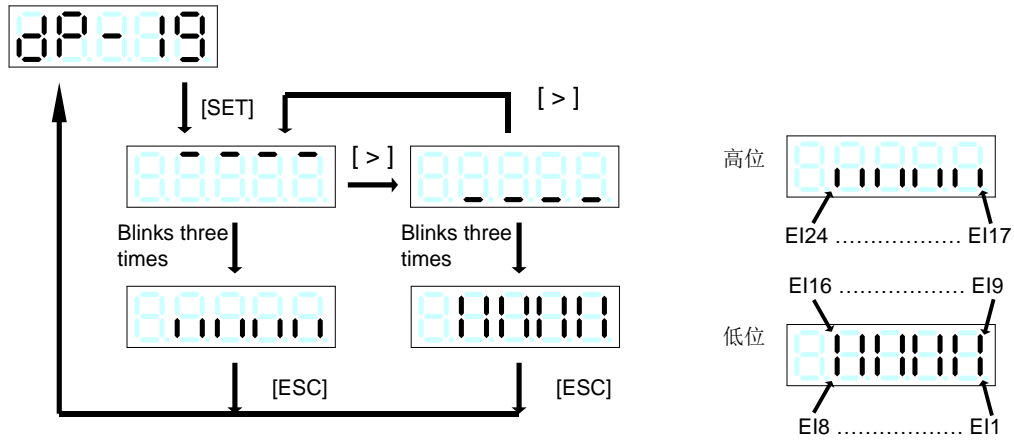

(20) Output signals

The ON/OFF status of sequence output signals issued by the servo driver is displayed.

The corresponding LED lights up when the output signal is turned on.

While all the output signals are off, the display shows “nonE.

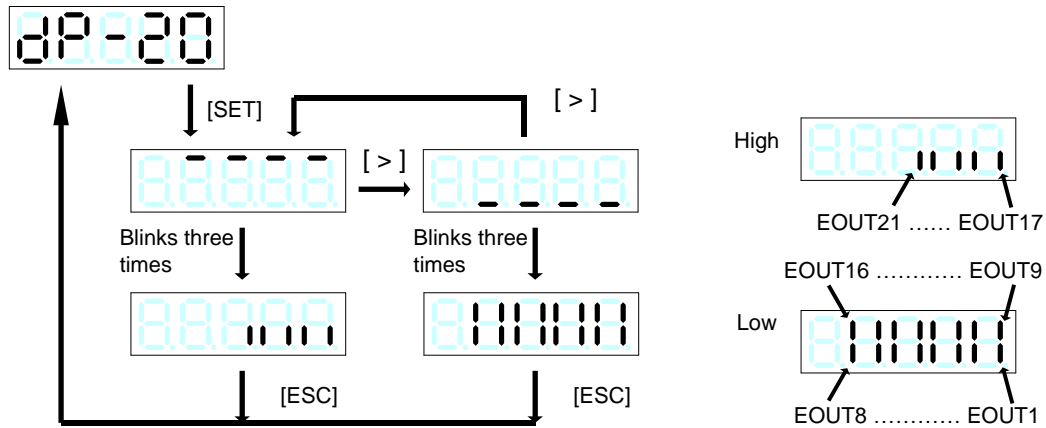

(21) OL thermal value (displayed digits: unsigned three digits)

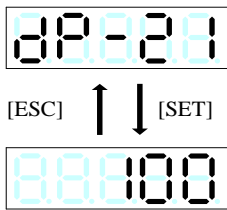

The load ratio to the load alarm level is displayed in percent.

An overload alarm is caused if this value reaches 100. The minimum increment is 1. The displaying range is from 0 to 100%.

3.5 Alarm Mode

In the alarm mode, the alarm detection content can be displayed.

Press the [MENU] key to display [AL-01], and press the [SET] key to display the data.

AL-01: Current alarm

AL-02: Alarm history

(1) Alarm at present

The alarm detected currently is displayed in a code.

•If the alarm reset is executed, the display will automatically return to the initial one. After an alarm is detected, the following is displayed automatically.

■ Alarm display

Order	Display	Name
1	oc1	Overcurrent 1
2	oc2	Overcurrent 2
3	oc3	Overcurrent 3
4	oS	Overspeed
5	Hu	Overvoltage
6	Et1	Encoder Trouble 1
7	Et2	Encoder Trouble 2
8	ct	Circuit Trouble
9	dE	Memory Error
10	cE	Motor Combination Error
11	Ec	Encoder Communication Error
12	Ec2	Encoder matching exception
13	ctE	EI (Control signal) Error

Order	Display	Name
14	oL1	Overload 1
15	oL2	Overload 2
16	LuP	Main Power Undervoltage
17	Luc	Control Power Undervoltage
18	rH3	Breaking Transistor Error
19	oF	Deviation Overflow
20	AH	servo driver Overheat
21	dL1	Absolute Data Lost 1
22	dL2	Absolute Data Lost 2
23	dL3	Absolute Data Lost 3
24	AF	Multi-turn Data Over Flow
25	oGE	Homing timeout
26	LS	Speed out or control
27	EF	External terminal alarm

Hint	<ul style="list-style-type: none"> •The alarm is automatically displayed upon detection. • If an alarm is detected, indication blinks quickly (at 0.5-second intervals) (when compared with regular blinks at 1-second intervals). • The alarm can be reset even in the test operation mode. • When an alarm is displayed, press and hold the [^] and [v] keys simultaneously for at least one second to reset the alarm. • After an alarm reset, display is restored to the initial display automatically. • If multiple alarms occur at the same time, the [^] key and [v] key can be used to switch and display the simultaneous alarms.
------	---

(2) Alarm history

Up to 20 past alarms can be displayed. Press the [^] and [v] key to scroll in the history.

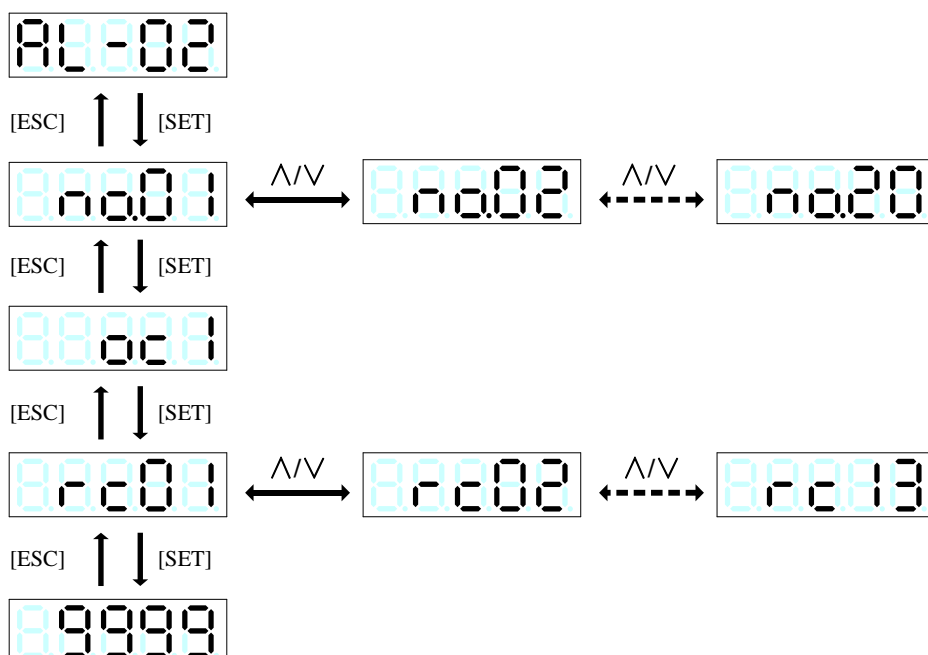

Display	Sub mode	Examples
rc01	Total time-main power supply	0
rc02	Unused	
rc03	Motor running time	05.09
rc04	Feedback speed	3000
rc05	Feedback speed before five min)	3000
rc06	Command speed	3000
rc07	Command torque	0
rc08	Motor current	0
rc09	Effective torque	0
rc10	DC link voltage	310
rc11	EC error counts	0
rc12	Command position	00
rc13	Sequence mode	PJG

Hint	The history can be cleared in the test operation mode [AF-06].
------	--

3.6 Parameter Edit Mode

Parameters can be edited in the parameter editmode.

Press the [MENU] key until [Pn-01] is displayed and press and hold the [SET] key for at least one second to select parameter editing.

After selecting parameter editing, press the [^] and [v] key to select the number of the desired parameter to be edited.

Press the [SET] key to edit the data.

Pn-01: Parameter page 1

Pn-02: Parameter page 3

Pn-03: Parameter page 3

Pn-04: Parameter page 4

(1) Parameter page 1

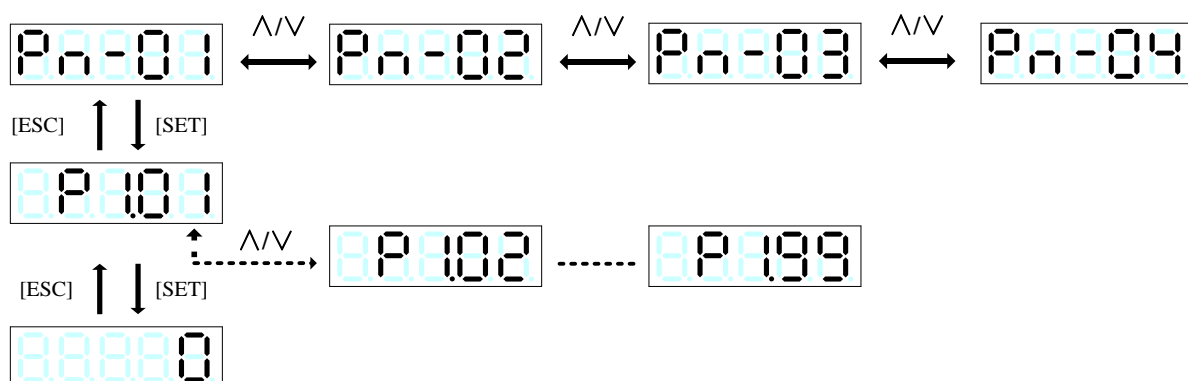

■ Value editing

When a parameter is loaded, the uppermost (leftmost) digit blinks. (If the parameter has the upper/middle/lower-digit display, the uppermost detail is displayed.) The blinking digit can be edited (the digit blinks at about 1-second intervals). Press the [^] and [v] key to change the value. Even if "9" changes to "0," no carry-over occurs (the higher order number does not change).

Similarly, the higher order number does not change when "0" changes to "9."

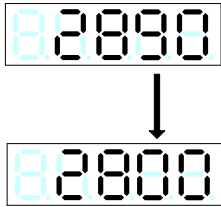

Press the [^] key at the tens digit to increase "9."

The tens digit changes to "0" but no change occurs to the higher order number.

Press the [SHIFT] key to shift the digit to be edited. The digit shifts from 1 to 10 as shown below, and returns to 1 after 10.

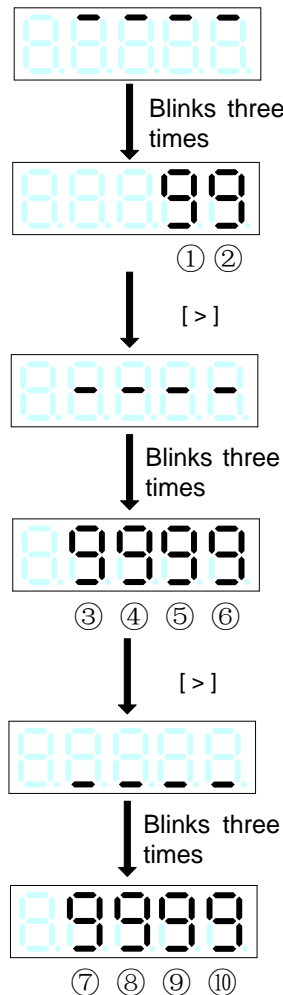

Settling the value

Press the [SET] key to settle the value. All digits blink simultaneously. The settled value remains. (The value blinks at about 0.5-second intervals when it is settled.)

Press the [MODE] key to return to the parameter number selection screen.

Value out of range

Values out of the allowable setting range can be entered as far as the number of digits allows. [Example] In case of parameter P1.07, you can enter in the range from 0 to 9999999(setting range:1 to 4194304). However, the value out of the permissible setting range is not reflected on the parameter (NG indication is caused).

Blinking display

When parameters which become enabled after the power is cycled once, the keypad display blinks.

■ An example of editing operation

Change parameter P1.07 (denominator of electronic gear) to100000.

Key operation		Remarks
		An example of indication in sequence mode
[MENU]		Return to mode selection.
[MENU]		Select the parameter editing mode.
[SET]		The parameter number is displayed.
[^]		Select parameter P1.07.
[SET]		Blinks three times.The set detail (upper three digits) of P1.07 is displayed next.
		The third digit of upper-digit display blinks.
[>]		Shift to the desired editing digit.
[^]		Increase the value to "1."
[>]		Shift the target to the first digit.
[>]		Blinks three times. The set detail lower four digits) of P1.07 is displayed next.
		The fourth digit of lower-digit display blinks.
[>]		Shift to the desired editing digit.
[v]		Change the value to "0."
[SET]		Settle the new value.
		After being settled, the value remains.

3.7 Positioning Data Edit Mode

In the positioning edit mode, you can edit positioning status, target position, rotation speed, stand still timer, M code, and acceleration and deceleration time.

- Pd_1: Positioning status
- Pd_2: Target position
- Pd_3: Rotation speed
- Pd_4: Stand still timer
- Pd_5: M code
- Pd_6: Acceleration time
- Pd_7: Deceleration time

■ Procedure (common)

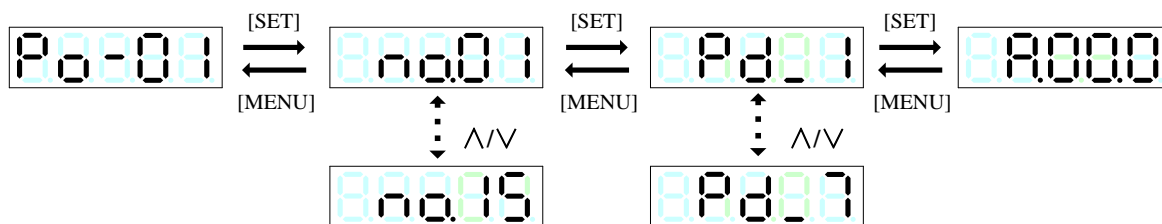

(1) Positioning status

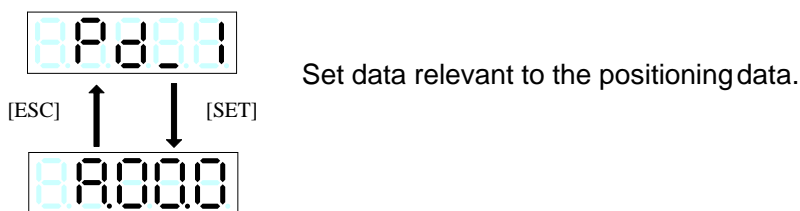

4th digit		2nd and 3rd digits		1st digit	
Indication	Command method	Indication	Step mode	Indication	M code setting
A	ABS	00	No designation	0	Disable
I	INC	co	Continuous	1	Output at startup
		cE	Cycle end	2	Output at completion

(2) Stop position

Specify the stop position of the motor. The setting value is within the range from -2,000,000,000 to 2,000,000,000 per 1 calibration

Set the stop position of the servo motor when the command mode is ABS; Set the incremental value when the command mode is INC.

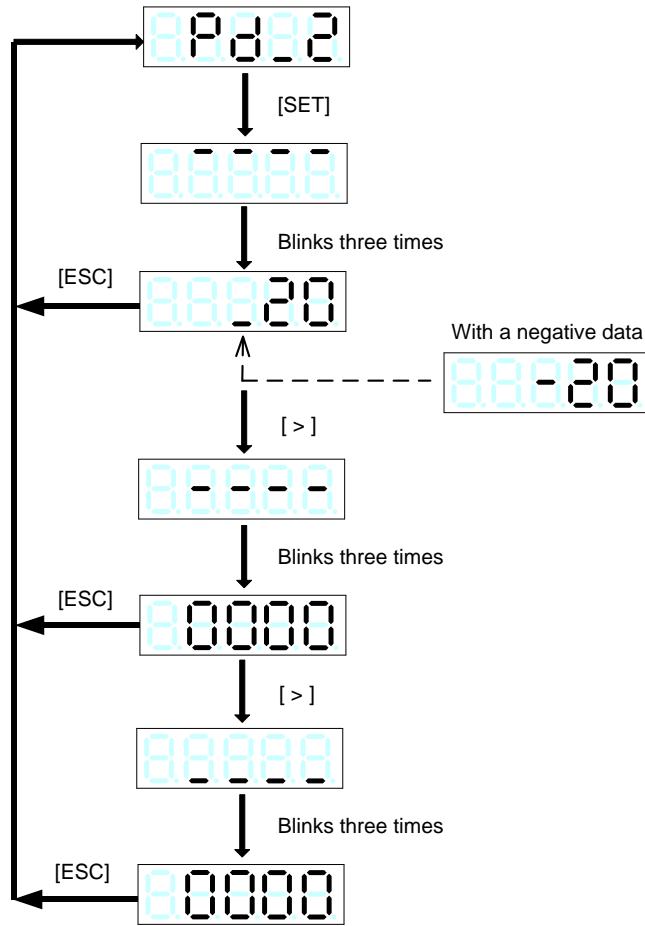

(3) Rotation speed

Set the travel speed to the motor target position. Use the motor shaft rotation speed for the setting value. The setting value range is from 0.01 to 6000.00 r/min in increments of 0.01. Note that the setting speed is not the machine travel speed.

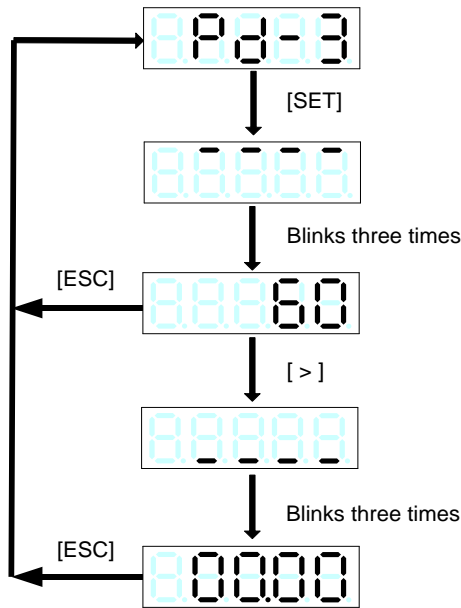

(4) Stand still timer

Set the stop time after the motor has reached the target position. The setting value range is from 0.00 to 655.35s in increments of 0.01.

After the stop time has elapsed, the sequence output signal (in-position signal [INP]) turns on.

The decimal point position can be changed in the parameter P2.42 (timer data decimal point position).

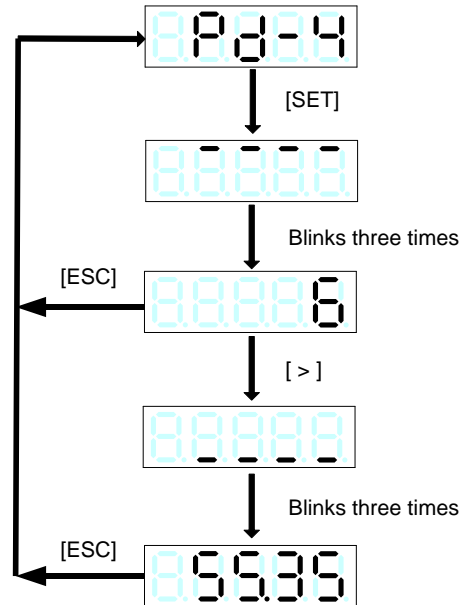

(5) M code

The M code output by executing positioning data can be edited. The setting range is from 00 to FF in hexadecimal. The minimum increment is 1. The default value is FF.

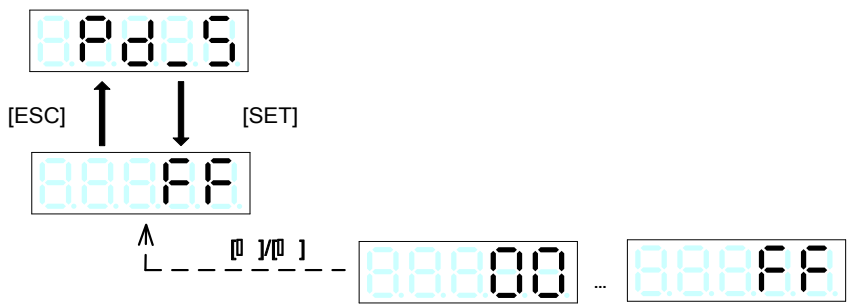

(6) Acceleration time

Set the motor acceleration time. The setting value range is from 0.0 to 99999.9 ms in increments of 0.1.

The setting value is the time until the motor rotation speed reaches 2000 r/min.

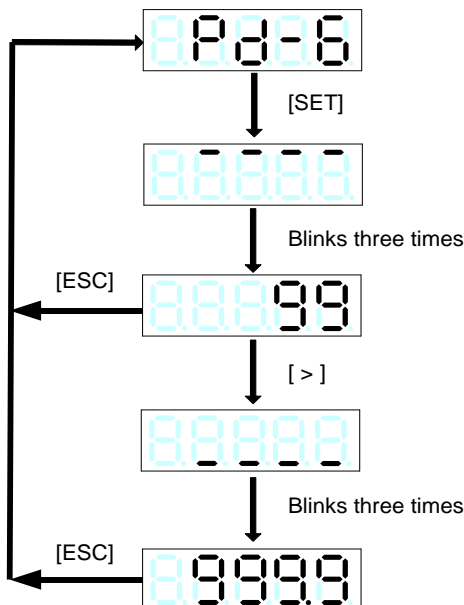

(7) Deceleration time

Set the motor deceleration time. The setting value range is from 0.0 to 99999.9 ms in increments of 0.1. The setting value is the time until the motor rotation speed reaches 2000 r/min.

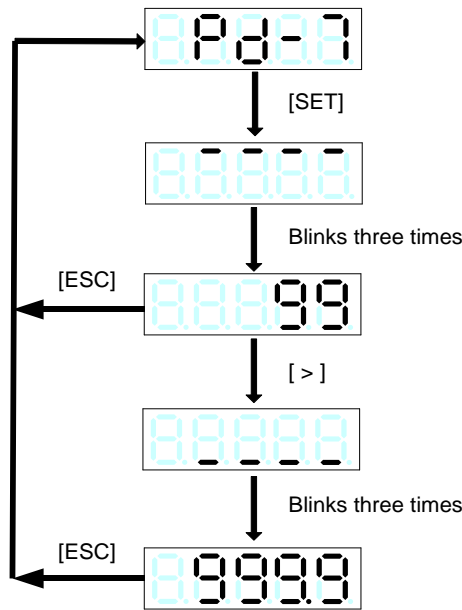

3.8 Test Operation Mode

In the test operation mode, you can operate keypad keys to rotate the servo driver or reset various data. Press the [MODE] key until [P2.77] is displayed, and press and hold the [SET] key for at least one second to execute test operation.

- | | | |
|----------------------------|--|--------------------------|
| AF-01: Manual operation | AF-06: Alarm history initialization | AF-11: Auto tuning gain |
| AF-02: Position preset | AF-07: Parameter initialization | AF-12: Easy tuning |
| AF-03: Homing | AF-08: Positioning data initialization | AF-13: Profile operation |
| AF-04: Automatic operation | AF-09: Auto offset adjustment | AF-14: Sequence mode |
| AF-05: Alarm reset | AF-10: Z-phase offset adjustment | AF-15: Teaching |

•NG display (common)

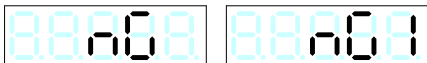

•Test run accompanying motor operation (AF-01, AF-03, AF-04, AF-12 and AF-13) .

If the motor operation is not available, the display indicates [NG].

The signals of forced stop, ±OT, and free-run are effective during test run.

Check these signals when [NG] is displayed.

•Test run accompanying parameter writing (AF-07, AF-09, AF-10, AF-11 and AF-12)

If the parameter P2.74 (parameter write protection) is set to "1" (write protect), the display indicates [NG].

Set P2.74 to "0" (write enable) before performing test run. (*)

•Test run accompanying positioning data write (AF-08 and AF-15)

If the parameter P2.75 (positioning data write protection) is set to "1" (write protect), the display indicates [NG].

Set P2.75 to "0" (write enable) before performing test run. (*)

(*) When the signal is turned off by assigning the edit permission command to the sequence input signal EIn, both the parameter and the positioning data are not allowed to be rewritten. Perform the test run with the EIn signal turned on.

(1) Manual operation

The servo motor rotates while the keypad key [] or [] is held down. The rotation speed of the servo motor depends on the setting of parameter P1.41.

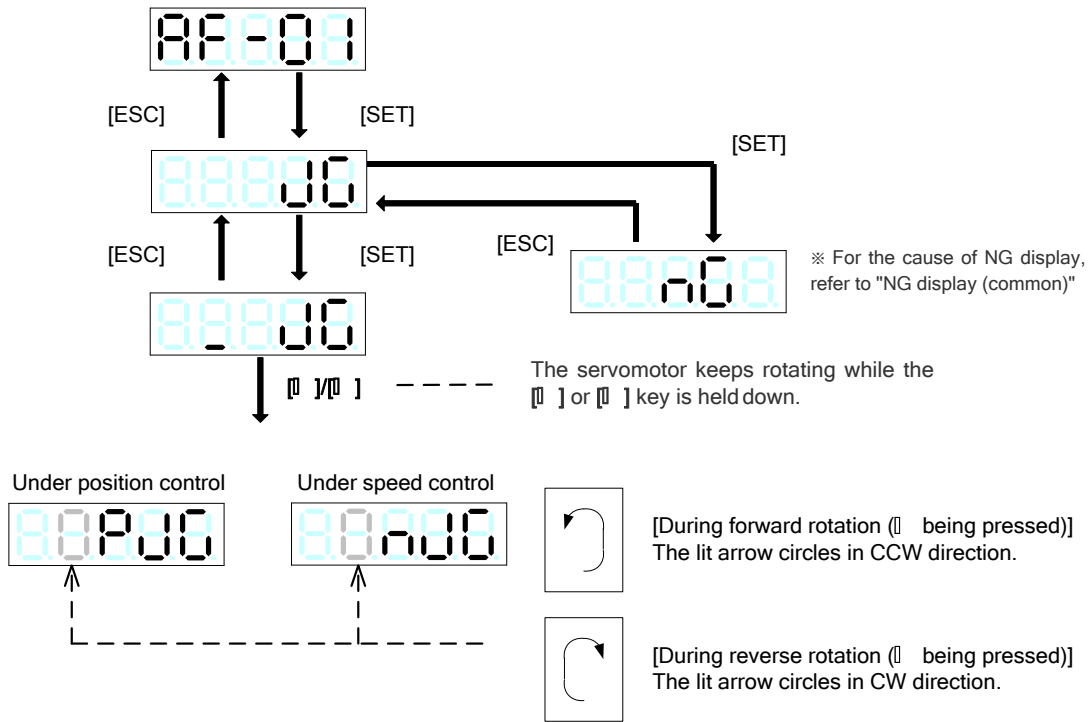

Note	The forced stop, external regenerative resistor overheat, ±OT and free-run signals are enabled even during test operation. Check these signals if test operation does not start.
------	--

(2) Position preset

The command position and the feedback position of the servo motor are reset to the value set in the preset position in P2.19.

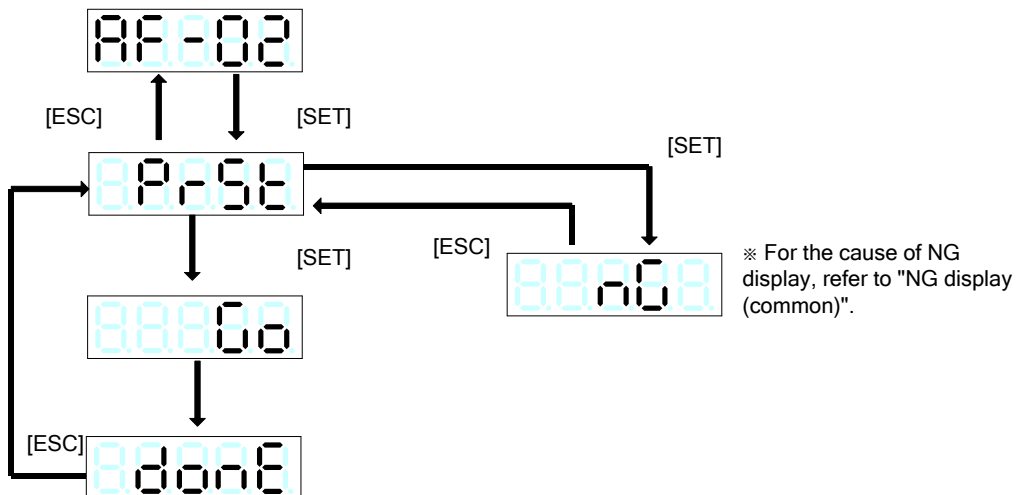

(3) Homing

Operate the keypad keys to perform homing. The homing profile follows the settings of parameters P2.06 through P2.18.

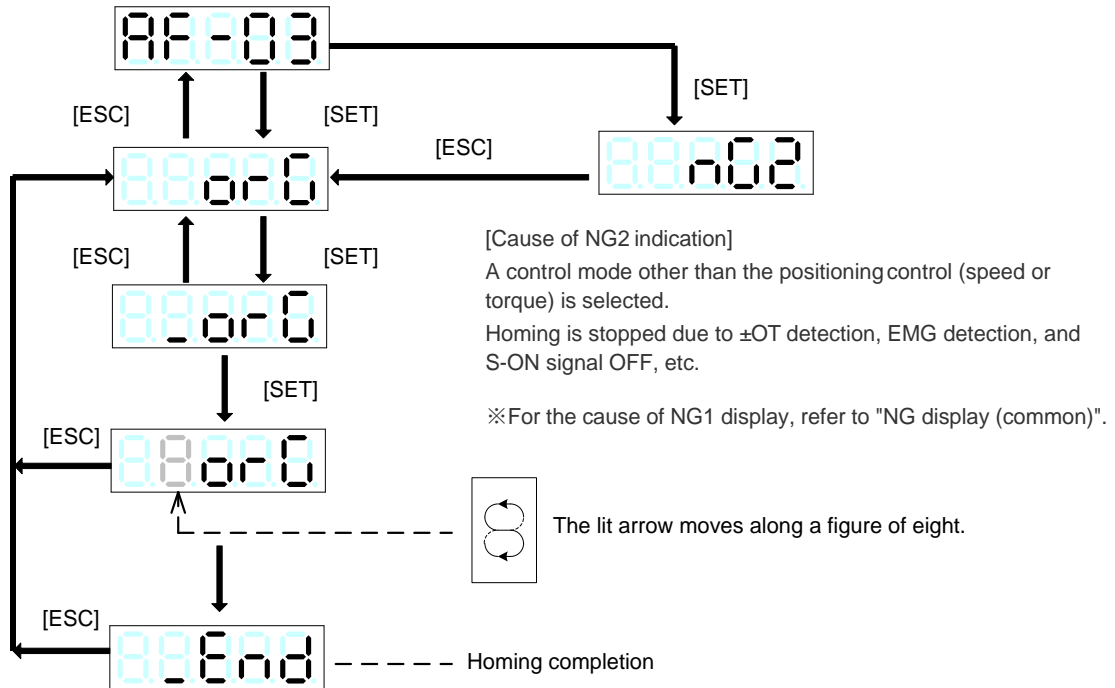

(4) Automatic operation

Operate the keypad keys to perform automatic operation.

Positioning is executed according to the registered positioning data 1 to 15.

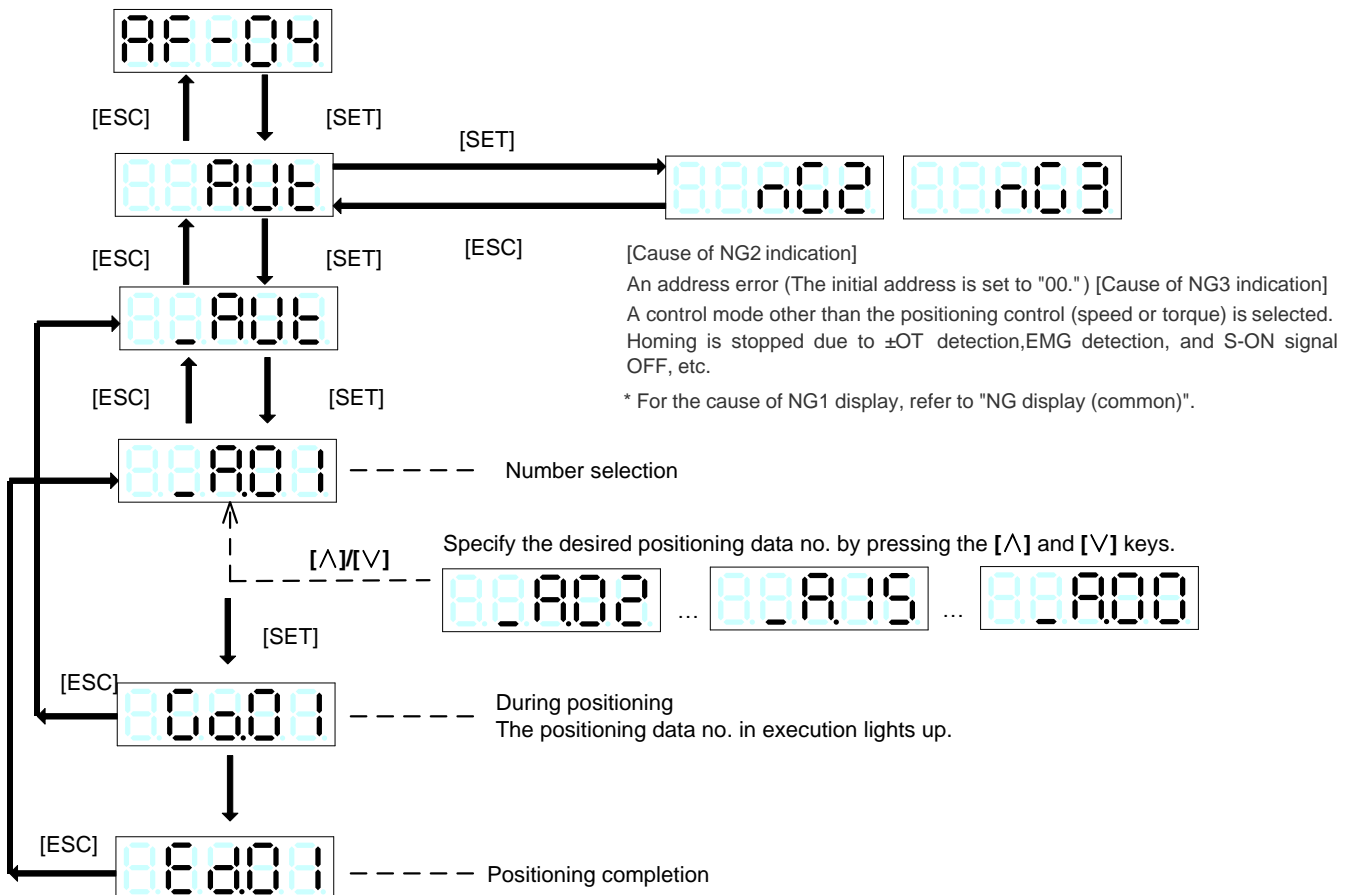

Note	The forced stop, external regenerative resistor overheat, ±OT and free-run signals are enabled even during test operation. Check these signals if test operation does not start.
------	--

(5) Alarm reset

The alarm currently detected in the servo driver is reset.

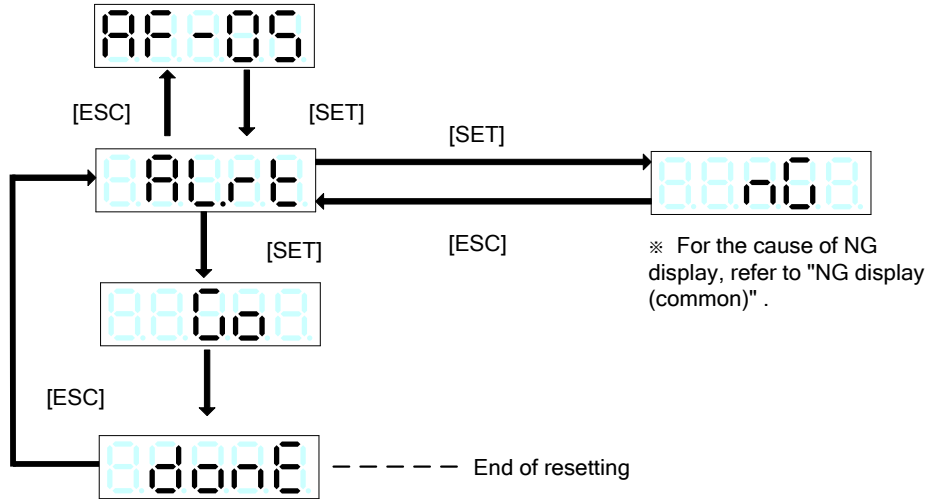

- The servo driver is not reset from some alarms through alarm resetting. To reset these alarms, turn the power off then on again.

Alarms removed through alarm resetting

Display	Name
oc1	Overcurrent 1
oc2	Overcurrent 2
oc3	Overcurrent 3
oS	Overspeed
Hu	Overvoltage
Ec	Encoder Communication Error
oL1	Overload 1
oL2	Overload 2
LuP	Main Power Undervoltage
Luc	Control Power Undervoltage
oF	Deviation Overflow
AH	servo driver Overheat
EF	External terminal alarm
oGE	Homing timeout
LS	Speed out or control

Alarms not removed through alarm resetting

Display	Name
Et1	Encoder Trouble 1
Et2	Encoder Trouble 2
ct	Circuit Trouble
cE	Motor Combination Error
ctE	CONTROL signal Error
rH3	Breaking Transistor Error
dL1	Absolute Data Lost 1
dL2	Absolute Data Lost 2
dL3	Absolute Data Lost 3
Ec2	Encoder matching exception

(6) Alarm history initialization

The history of detected alarms recorded in the servo driver is deleted. The alarm detection history (alarm history) can be monitored with [AL-02] in the alarm mode.

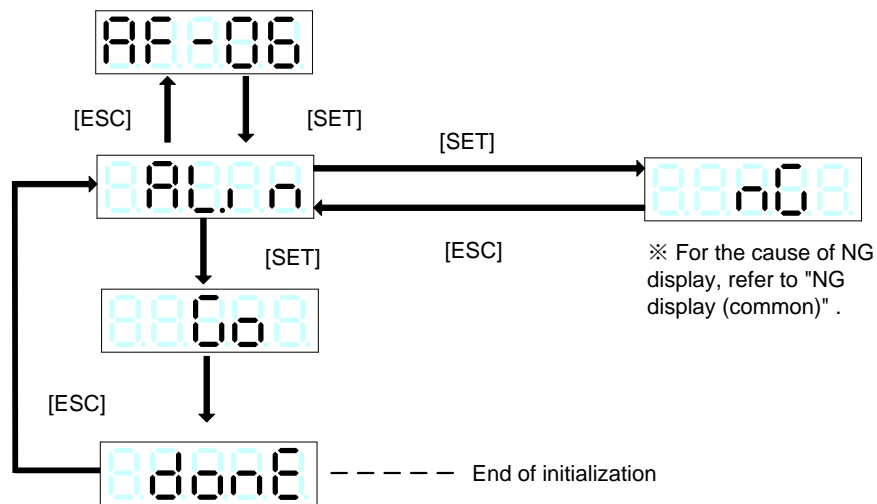

The alarm history is retained even after the power is turned off.

(7) Parameter initialization

Parameters are initialized. After initializing parameters, be sure to turn the power off then on again.

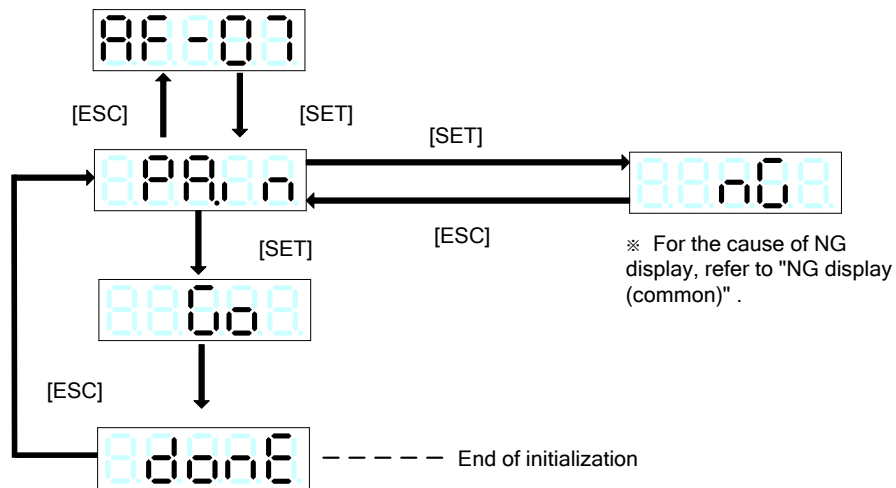

(8) Positioning data initialization

The positioning data are initialized. After initializing, turn the power off then on again.

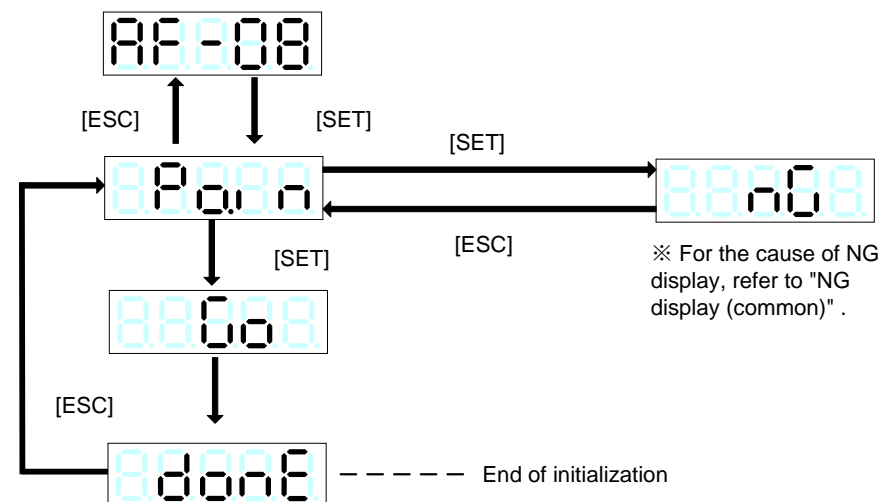

(9) Auto offset adjustment

The current input voltage supplied at the analog speed/torque command voltage input [VREF] / [TREF] terminal is reset to 0 V.

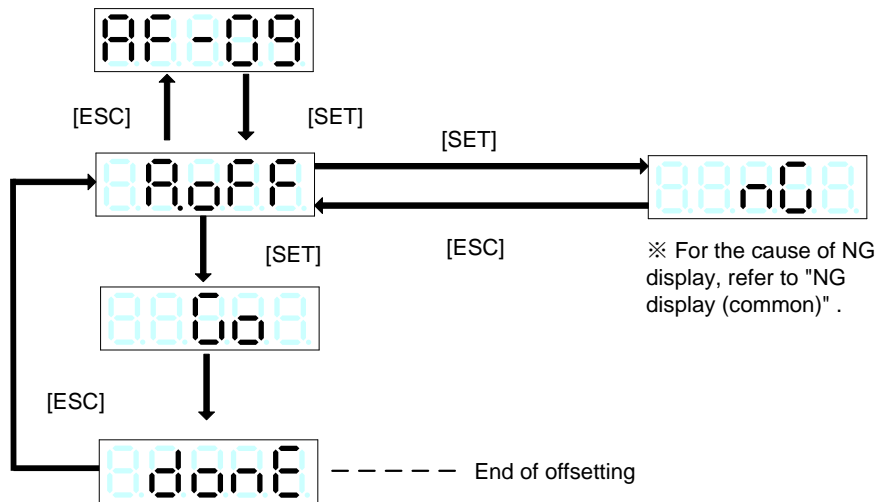

If both the X1,X2 and X3 terminals of multi-step speed selection are turned off with the FWD (REV) signal, the output shaft of the servo motor rotates according to the analog speed command voltage. The output shaft of the servo motor may rotate at a small speed even if the speed command voltage is 0 V. Use the "zero clamp function (parameter P3.35)" when necessary.

Follow the procedure below to adjust the offset voltage.

- [1] Supply 0 V to the [VREF] and [TREF] terminals. The operation command can be given or not given.
- [2] Select [AF-09] at the keypad and press the [SET] key to automatically adjust the offset.
- [3] Turn the operation command [S-ON] signal on and check that the output shaft of the servo motor does not rotate.

Hint	<p>Results of adjustment are stored in parameter P3.32 and P3.34.</p> <p>According to variation in the ambient environment of the servo driver, offset adjustment may become necessary. However, do not select if the host controller uses the speed command voltage and division output pulse (feedback) to control the servo driver.</p>
------	--

(10) Z-phase offset adjustment

The current position is defined to be the Z-phase position. After the Z-phase offset is defined, the distance between the current position and Z-phase is automatically entered in parameter P1.12 (Z-phase offset).

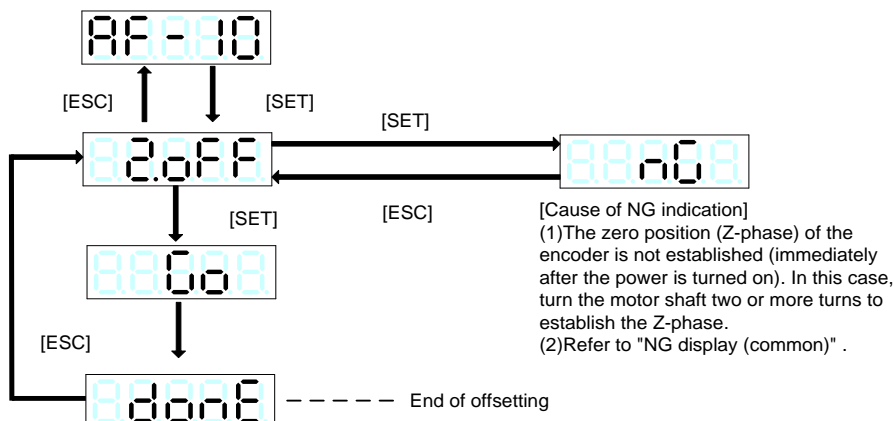

(11) Auto tuning gain

Parameter P1.15 (auto tuning gain 1) is updated at real time. The data is reflected at real time merely through increase/decrease of data, different from regular parameter entry

(Parameter P1.15 is not updated if no operation is made; press the [SET] key to register parameter P1.15).

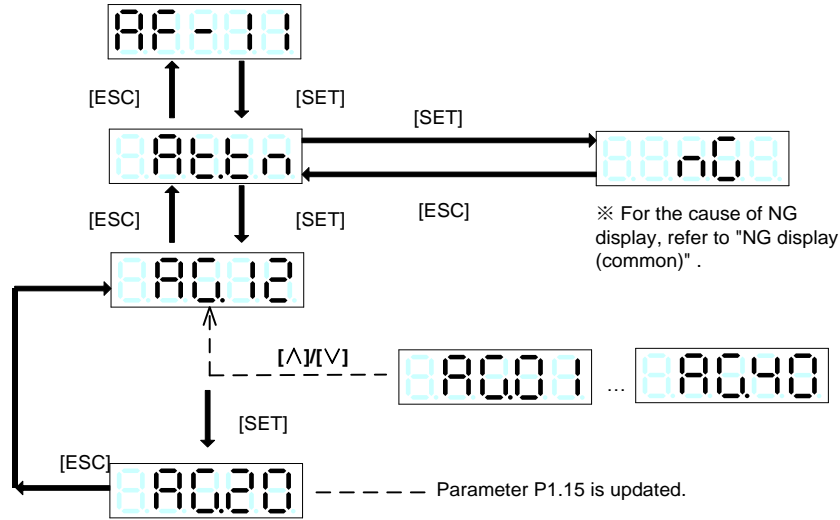

(12) Easy tuning

Operate the servo motor automatically and adjust the auto tuning gains automatically.

Best adjustment can be obtained according to the machine even if cables to the host control unit are not connected.

The operation pattern includes two variations: slow running and easy tuning.

For details, refer to "CHAPTER 7 SERVO ADJUSTMENT."

Operation pattern name	Travel distance	Operation frequency	Acceleration time	Deceleration time	Rotation speed	Timer	Direction of rotation	
							Go path	Return path
Slow running	P1.20	Once	P1.37	P1.38	10 r/min	P1.22	P1.23	
Easy tuning	P1.20	Max. 50 times	Automatic Calculation	Automatic Calculation	P1.21	P1.22	P1.23	

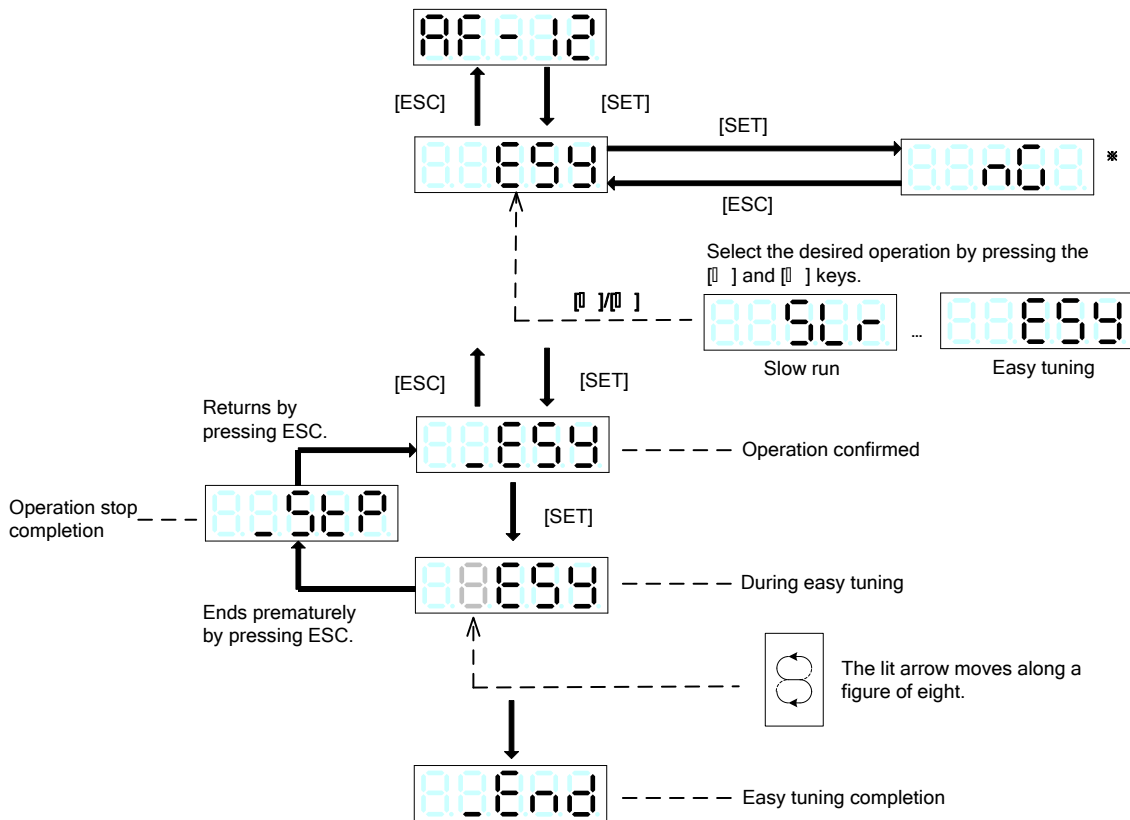

*[Cause of NG1 indication]

- The parameter P1.13 (tuning mode) is set to "12" (manual).
- The parameter P2.74 (parameter write protection) is set to "1" (write protect).
- Operation is disabled due to EMG detection or alarm detection.
- During motor rotation.

[Cause of NG2 indication]

- Operation is stopped due to ±OT detection, EMG detection, and S-ON signal OFF, etc.

[Cause of NG3 indication]

- The motor is oscillating even when the auto tuning gain is set to 4 or lower.

(13) Profile operation

Operate the servo motor continuously. Once started, reciprocal operation (depending on parameter P1.23) continues until operation is stopped.

Continuous operation is possible even if cables to the host control unit are not connected. Use this mode to check the effective torque or for other purposes.

Operation pattern name	Travel distance	Operation frequency	Acceleration time	Deceleration time	Rotation speed	Timer	Direction of rotation	
							Go path	Return path
Profile operation	P1.20	Endless	P1.37	P1.38	P1.21	P1.22	P1.23	

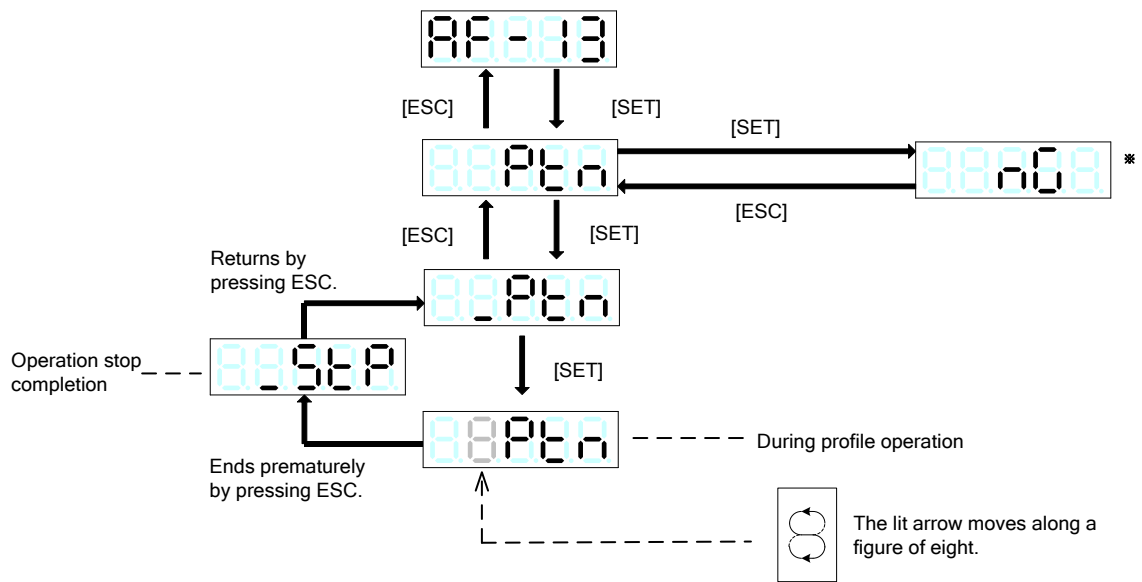

*[Cause of NG1 indication]

- Operation is disabled due to EMG detection or alarm detection.
- During motor rotation.

[Cause of NG2 indication]

- Operation is stopped due to \pm OT detection, EMG detection, S-ON signal OFF, and alarm detection, etc.

(14) Sequence test mode

You can issue sequence output signals and show statuses without connecting the servo motor as if the servo motor actually operates in response to sequence input signals.

Use this mode to check the program (sequence) of the host controller or similar.

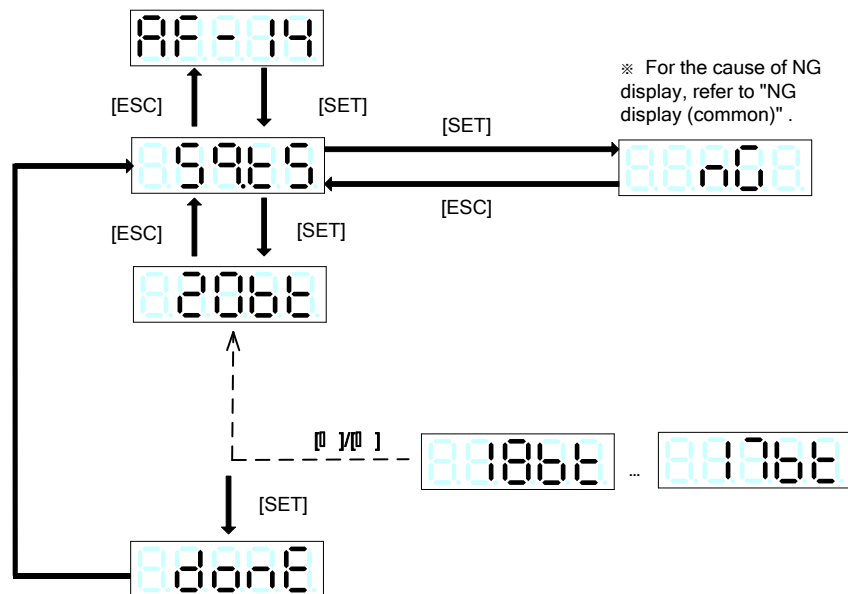

Hint	<p>During the sequence test mode the 7-seg display (all the five digits) flashes with blinking with interval of several seconds. The display does not flash with blinking during key operation and data editing.</p> <p>The sequence test mode is not finished even if another mode other than "AF-14" indication is started. To exit from the mode, turn the main power off then on again. If parameter P2.89 is set at "1", change the reference value to "0" before turning the power off and on.</p>
------	--

(15) Teaching

After operating the servo motor in the manual operation or pulse operation or similar, the target position can be written to the specified address as the positioning data.

- Only the target position can be written and other data need to be set separately.

(Positioning status, rotation speed, stand still timer)

If the initial positioning data is selected for teaching, the command method of positioning status is set to ABS.

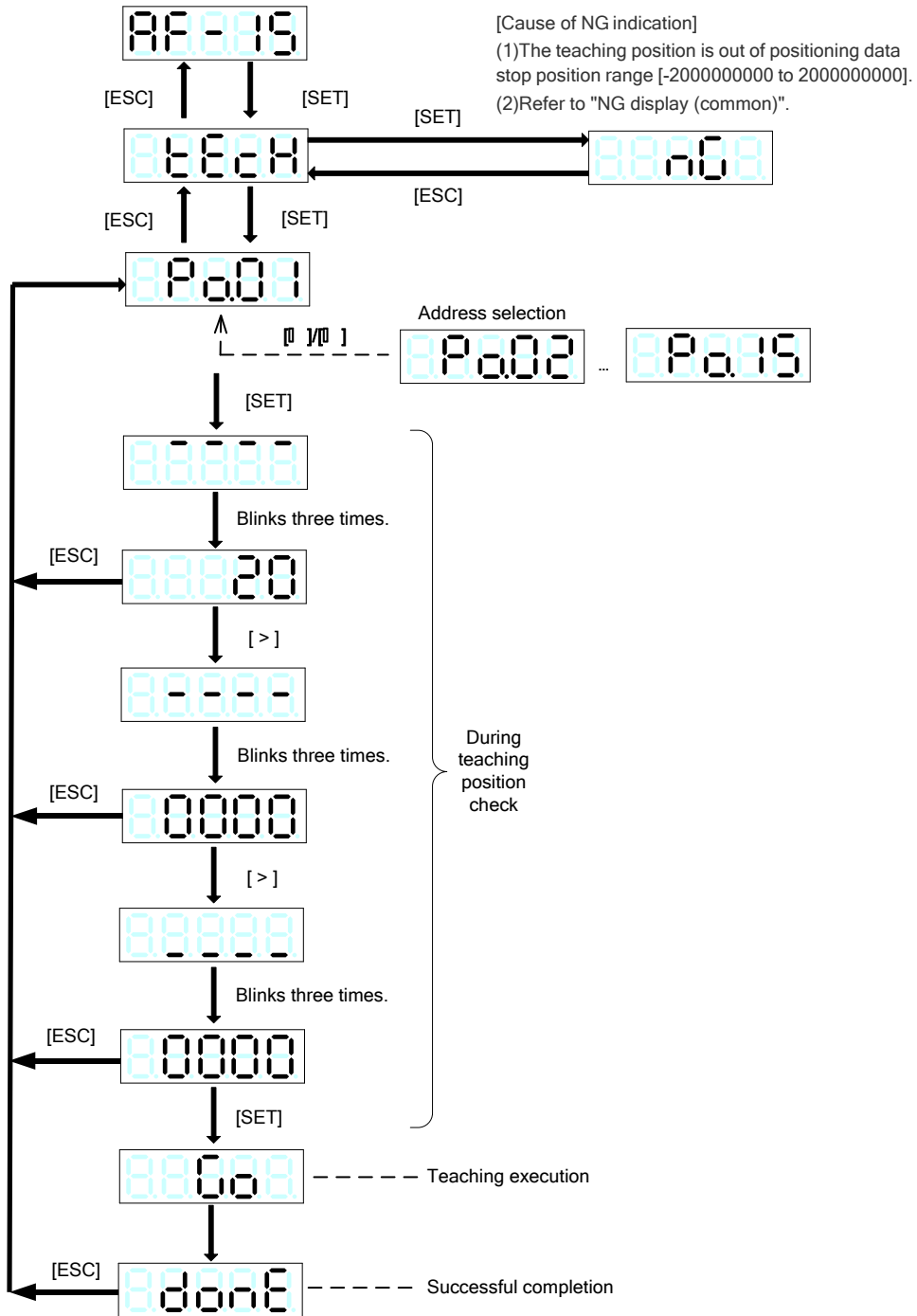

4.1 Signal Description (Input Signal Order)

For safety, the servo motor drive's input signal is deal with the signal of motor stop firstly.

Item	Description	Corresponding signal (function NO.)
01	Most priority operation signal	<ul style="list-style-type: none">• Free-run command (54)• Servo ON (1)
02	Priority operation signal	<ul style="list-style-type: none">• Forced stop (10)
03	Signal to limit the torque	<ul style="list-style-type: none">• Torque limit 0 (19)• Torque limit 1 (20)
04	Signal to stop the servo motor	<ul style="list-style-type: none">• +OT (7)• - OT (8)• Command pulse inhibit (26)• Pause (31)• Positioning cancel (32)• Deviation clear (50)
05	Signal to make the motor rotatable	<ul style="list-style-type: none">• Forward rotation (2)• Reverse rotation (3)• Auto-start(4)• Homing (5)
06	Signal to decide the home position	<ul style="list-style-type: none">• Homing LS (6)• Interrupt input (49)• Position preset (16)
07	Signals regardless of the operation of the servo motor	<ul style="list-style-type: none">• Alarm reset (11)• Edit permission command (55)

- If using the free-run command, the moving element of lifting mechanical system may drop. If it is unnecessary, please do not equip with it.
- The response time of external input terminal and output terminal is 1 [ms].

If the settings of reducing deviation or zero signals etc are performed, it may not be identified by the host controller PLC (Generally, the scanned time of the PLC is dozens of [ms]).

4.2 Operation Procedure

SDV3 servo motor drive perform speed control and torque control by analog voltage, position control by pulse, positioning data operation by EI/EOUT signal or RS485 communication and Immediate value data operation by RS485 communication.

Select the operation mode and set the parameter according to the following flow chart.

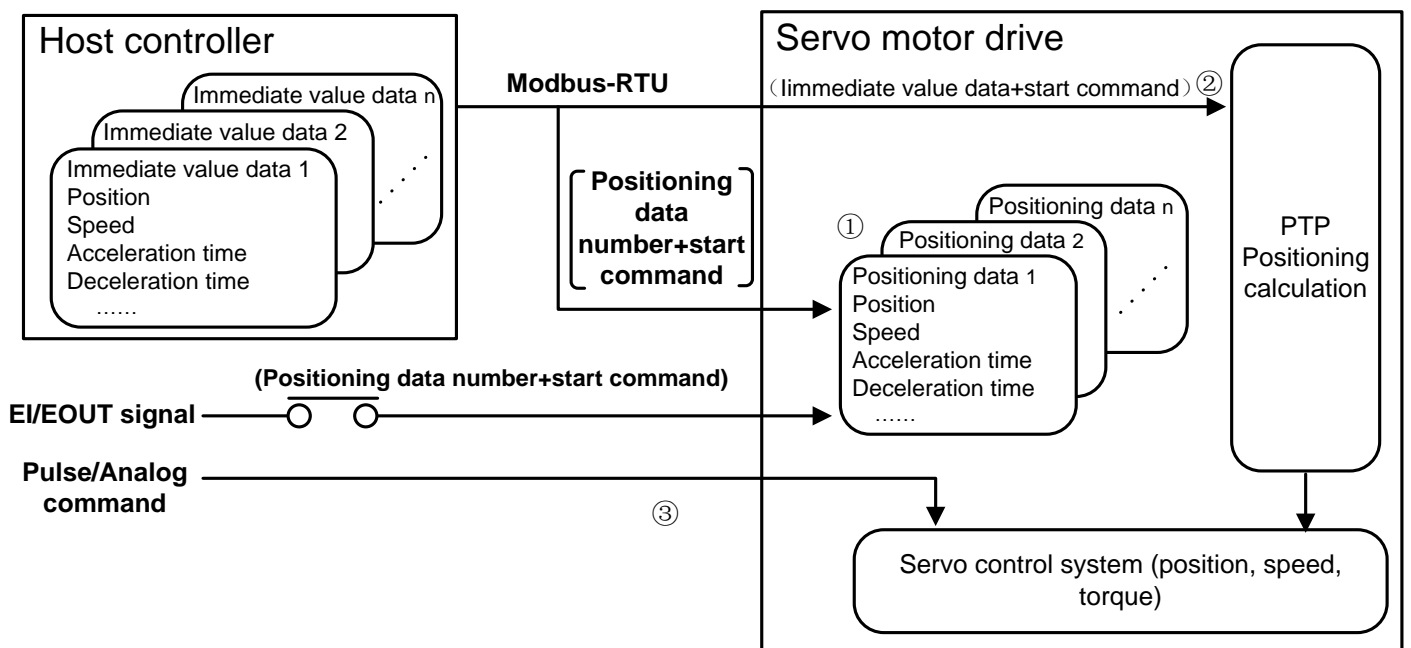
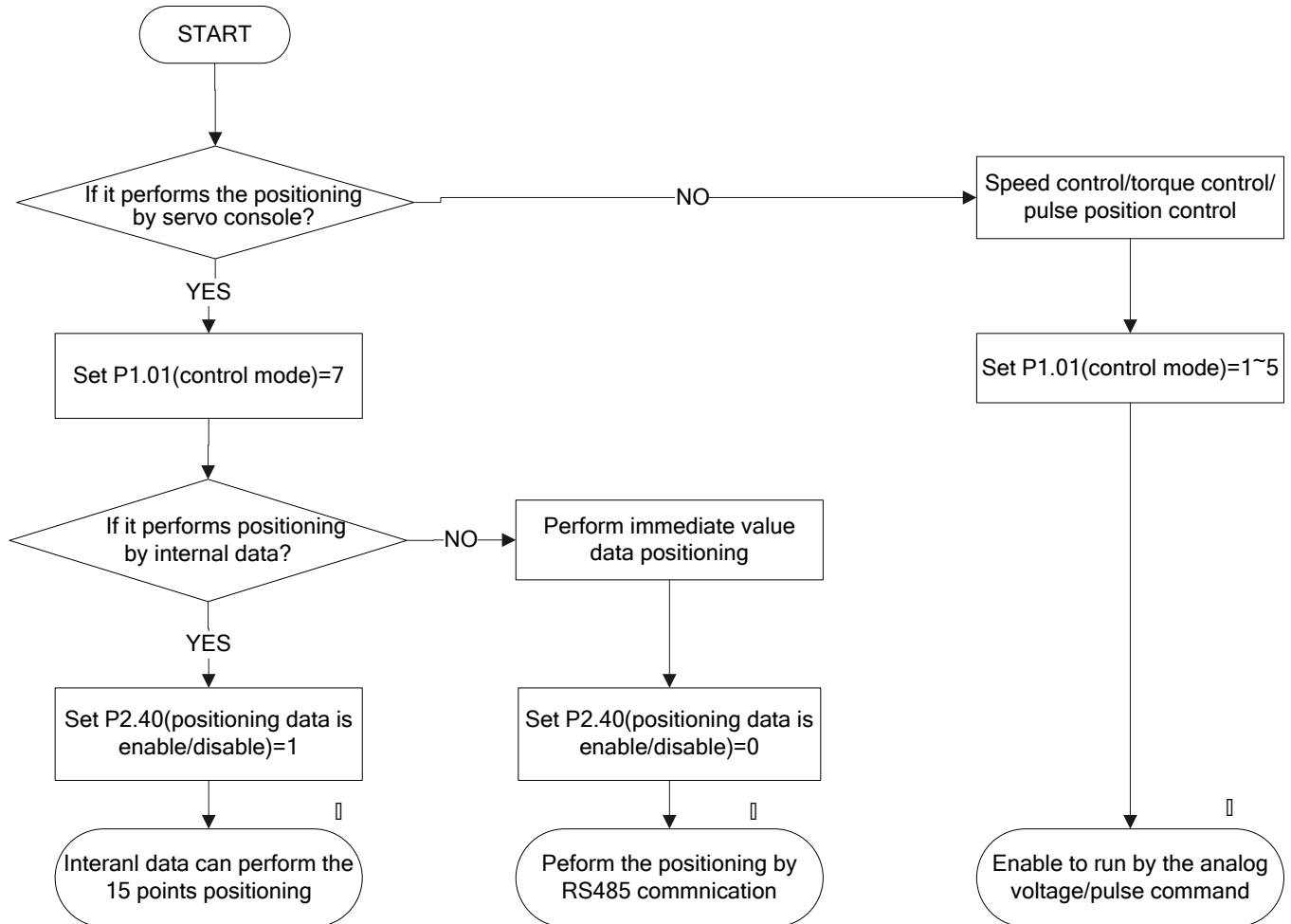

4.3 Operation Check

4.3.1 Power On

Connect the commercial power and servo motor drive to the servo motor.

Regarding the wiring method, please refer to “chapter 2 hardware description and installation”

- **Supply commercial power**

Operate control power and main circuit power to supply power.

If necessary, please insert an electromagnetic contactor in the upstream of the main power so that it can be shut off at any time.

The following results indicate the correct state.

(1) The charge LED lights up in red.

(2) If the servo motor drive is being factory default, below content is displayed on the keypad.

-



- **If the charge LED does not light up**

No power is supplied to the main circuit power supply (R, S, T). Please check the power voltage.

When 380[V] is supplied, please convert the voltage to 220[V] by the converter before supply the power to the servo motor drive (otherwise, it may damage the servo motor drive).

- **If the keypad display does not light up**

The power required for the servo is not supplied to the power supply (R, S, T).

Please check the power voltage.

- **If the error code on the display blinks**

If the keypad display blinks, an alarm is detected.



4.3.2 Power On /Servo Control-Ready[S-RDY]

The servo-control-ready signal [S-RDY] is issued about 2 seconds after the main power is supplied.

The CPU inside the servo motor drive diagnoses itself and if the result is correct, the signal is issued and remains turned on until the power is shut down.

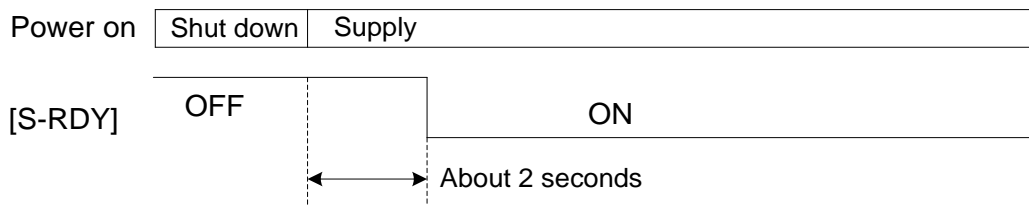

4.3.3 Servo ON[S-ON] / Ready for Servo On [RDY]

Issue the signal to turn the servo motor on and make it rotatable, After the servo-on is turned on and the motor becomes ready to rotate, the ready for servo-on [RDY] signal is turned on and the motor is in the ready-to-rotate state can be checked.

If the signal is turned off during motor rotation, the motor decelerates to stop, after it is stopped, the motor free-run.

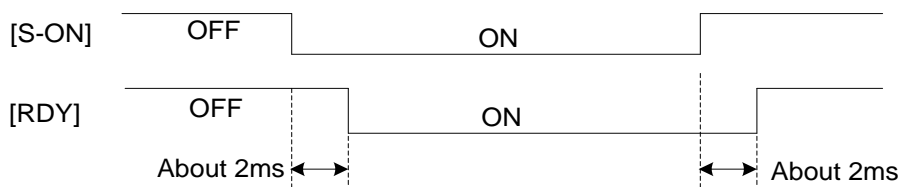

The servo motor drive input signal can be always enabled with parameters P3.26~P3.30.

Servo-on [S-ON] turned on before power-on does not cause breakage to the servo motor drive.

4.3.4 Shut Down

If the power is cut off when the S-ON signal is being ON, the servo motor drive detects a low voltage alarm.

When the S-ON signal is being ON, and power ON in 1s after that the DC link voltage is decreased to 200V or below, the servo motor drive detects the low voltage of the main circuit. After 1s or above, it can not detect the low voltage of the main circuit.

It may not impact the servo motor drive even though detecting the low voltage of the main circuit and outputting the alarm.

However, please do not run and stop the servo motor by connecting with and cutting off the power frequently. Otherwise, the servo motor drive may cause failure.

If turning the run command OFF before cutting off the power, the main power undervoltage is not detected.

P2.67 (detects and outputs alarm when it is low voltage) can be used to check if there is main power undervoltage and outputs alarm.

P2.63 (action state at main power shutoff) for determining the stop action at main power shutoff

If the power is shut off during operation, the servo motor drive turns off ready for servo-on [RDY] to stop the internal CPU.

4.4 Operation

4.4.1 Additional Function Test at Keypad

Use additional function mode of the keypad to check the motor rotation.

When the servo motor is equipped with a brake, supply DC24 [V] to release the brake.

The motor rotates even without the external terminal signal.

Relative parameter setting and default value are shown below.

To enable the acceleration/deceleration time with the speed control, set the parameter P1.36 (Acceleration /deceleration selection at speed control) to "1" (enable).

Parameter	Name	Setting range	Default value
P1.37	acceleration time 1	0.0~99999.9 [ms]	100.0
P1.38	deceleration time 1	0.0~99999.9 [ms]	100.0
P1.41	Manual feed speed 1/speed limit under torque control 1	0.01~Max. speed [r/min]	100.0

• Manual operation at Keypad

Please check the rotation of the servo motor's output shaft by following the below procedure

[1] Use key [MENU] to start the additional function mode [AF-01].

[2] The servo motor rotates while the key on the keypad is held down.

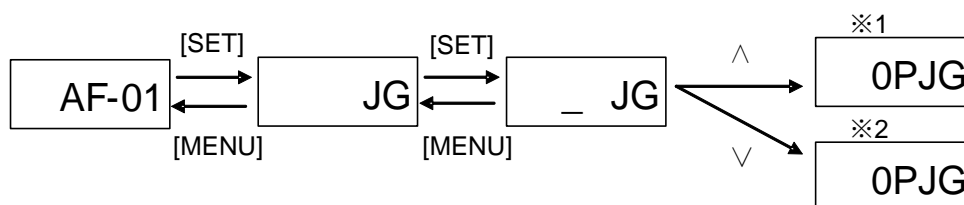

※1) 【During forward rotation(pressing ^)】

 Light bar turns in counter clockwise.

※2) 【During reverse rotation(pressing v)】

 Light bar turns in clockwise.

After checking that the servo motor shaft is rotating, press key [MENU] to return until [AF-01] is displayed again.

If [AF-01] is not displayed again, rotation with the external terminal signal is impossible to rotate.

4.4.2 Position Control (pulse)

The shaft rotation is controlled under the position control according to the pulse input of the servo motor drive.

The pulse operation procedure is shown below:

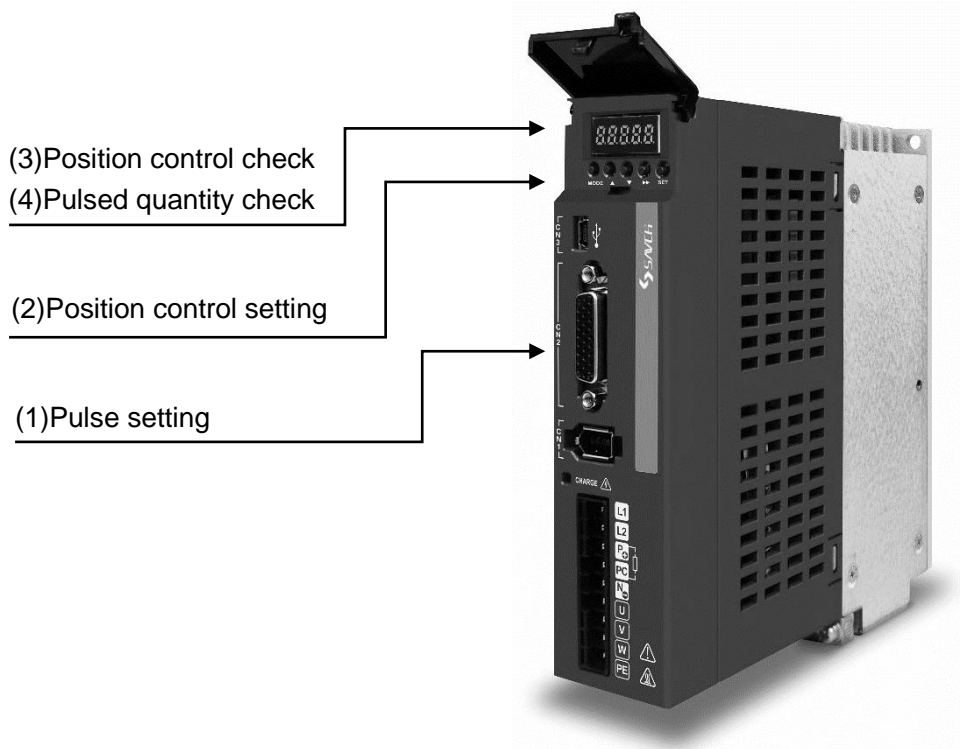

(1) Pulse setting

According to the pulse format of the host pulse generator, enter the following parameters.

◆ The parameters with “*” indicate that they are enabled only when power on again after parameter setting.

Parameter	Name	Setting range	Default value
*P1.03	Command pulse input method and form selection	00: differential, command pulse/symbol 01: differential, forward rotation pulse/reverse rotation pulse 02: differential, A/B phase orthogonal pulse 03: open collector, command pulse/symbol 04: open collector, forward rotation pulse/reverse rotation pulse 05: open collector, A/B phase orthogonal pulse	00
*P1.05	Number of command input pulse per revolution	0: Electronic gear rate is enabled(P1.06/07) 64~1048576 [pulse]: this parameter setting is enabled	0
P1.06	Numerator 0 of electronic gear	1~4194304	16
P1.07	Denominator of electronic gear	1~4194304	1

• To assign 4000 pulses per revolution

P1.05 = 4000

- Connect with a 5[mm] ball screw directly, in case that mechanical system moving distance per pulse is 0.001 [mm] (17bit)

Then from $(5/131072) \times (P1.06/P1.07) = 1/1000$, the conclusions are shown as below:

P1.05 = 0

P1.06 = 16384

P1.07 = 625

(2) Position control setting

The factory default setting of the servo motor drive is shown as below.

- Assignment of input terminal (EI input signal)

EI 1: Servo ON[S-ON](function NO.1)

EI 2: Alarm reset [RST](function NO.11)

EI 3~EI 24: No assignment

- Parameter P1.01: control mode selection=0(position control)

Therefore, the servo motor drive is under position control when it is power on

EI 1: by turning Servo ON[S-ON] ON, input pulse, the motor rotates.

(3) Position control check

Check that it is under position control. The 3rd word "P" from the right side indicates position control.

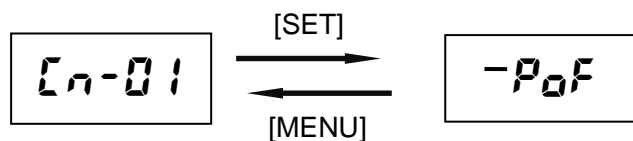

(4) Pulsed quantity check

Output the pulse from the host controller. And check if the counter value is the consistent to the servo motor driver's.

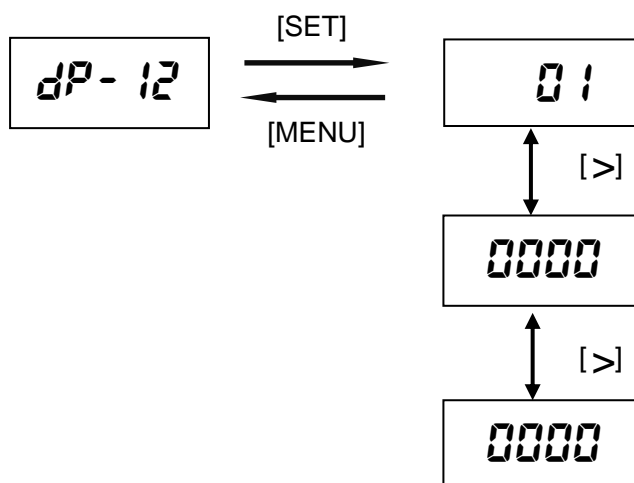

Display example of 10000000 pulses.

- When A/B phase orthogonal pulse is entered, the display value is 4 times of pulsed quantity

4.4.3 Speed Control

The shaft rotation speed is controlled under the speed control mode according to the speed command voltage input [VREF] of the servo motor drive or parameter setting.

When P1.01 = 1, the speed control mode starts after the RDY signal is turned on.

While the manual forward command [FWD] or manual reverse command [REV] signal is turned on, the motor accelerates and turns at a constant speed, and decelerates starts when the signal is turned off.

Use the ACC (14) input signal to switch the acceleration/deceleration time.

The acceleration/deceleration time follows the parameter setting.

The rotation speed follows the X1 (51)、X2 (52) and X3 (53) input signal or speed command voltage[VREF].

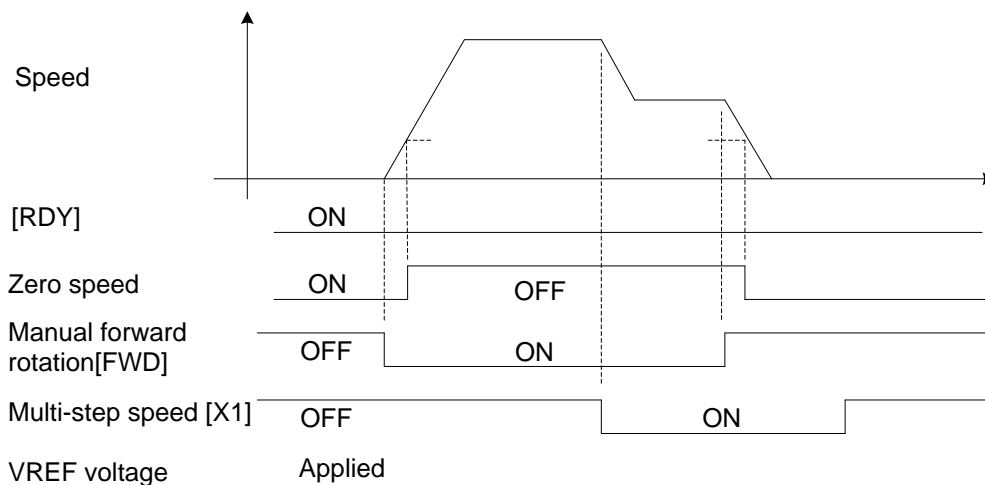

Use parameter P3.35 to specify the zero clamp level in relation to the [VREF] input.

The following signal is active in the speed control mode.

- Zero speed

The signal is turned on if the feedback speed of the motor (present shaft rotation speed of the motor) falls below a certain value.

4.4.4 Torque Control

The shaft rotation is controlled under torque control according to the torque command voltage input[TREF] of the servo motor drive or parameter setting.

When parameter P1.01 = 2, the torque control starts after the RDY signal is turned on.

The torque is output while the manual forward rotation [FWD] or manual reverse rotation signal is turned on, while the torque is reduced to zero after the signal is turned off.

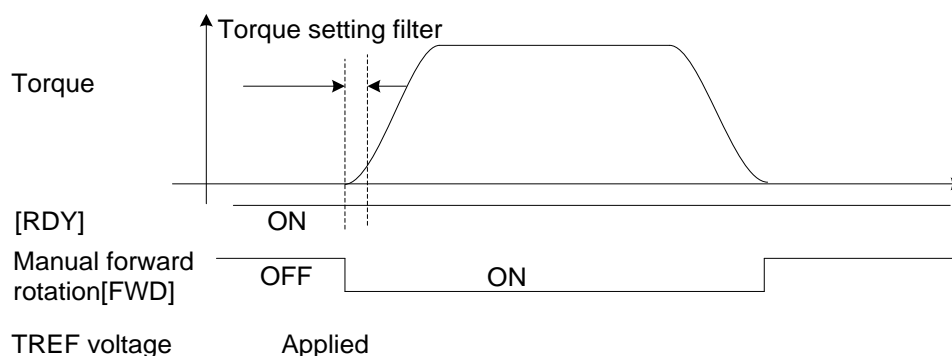

Use parameter P1.60 to specify the torque setting filter.

The max motor rotation speed can be controlled.

Parameter	Name	Setting range	Default value
*P2.56	Speed limit selection at torque control	0: parameter(P1.26) 1: Multi-step speed selection, VREF terminal voltage	0

- The speeds corresponding to the multi-step speed selection (X3, X2, X1) are P1.41~P1.47 or [VREF] terminal.
- Since speed control is not performed, therefore, the actual speed limit level is different.

4.4.5 Mode Selection

The operation control mode can be changed with parameter settings shown in below table and control mode switching signals.

P1.01: Control mode selection	Control mode(function NO.36)	
	Control mode selection = OFF	Control mode selection = ON
3	Position control	Speed control
4	Position control	Torque control
5	Speed control	Torque control

The operation pattern with “5” specified in P1.01 (speed control ↔ torque control).

The command is issued by the voltage input of VREF and TREF.

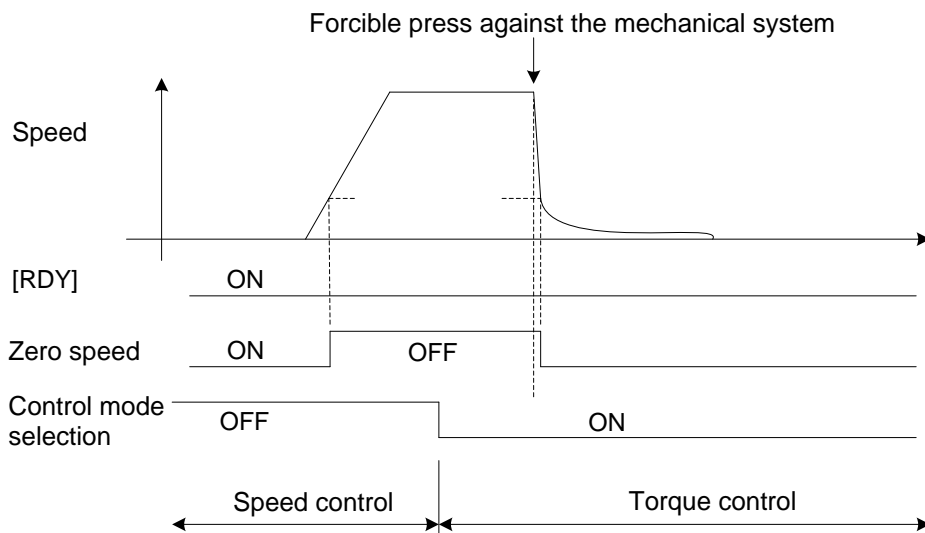

To forcible press against the mechanical system as shown in figure above, torque limit should be adopted with a pressing material or the like.

For the torque control, refer to section 4.4.4.

No control mode switching condition is provided. It can be switched at any time.

When the control mode is “6”(extension mode), the control mode is activated when the zero speed signal is turned on.

4.4.6 Extension Mode

Servo motor is controlled by analog and pulse at extension mode.

If the pulse operation is performed, pulses are enabled while “position control” and “pulse ratio” are turned on.

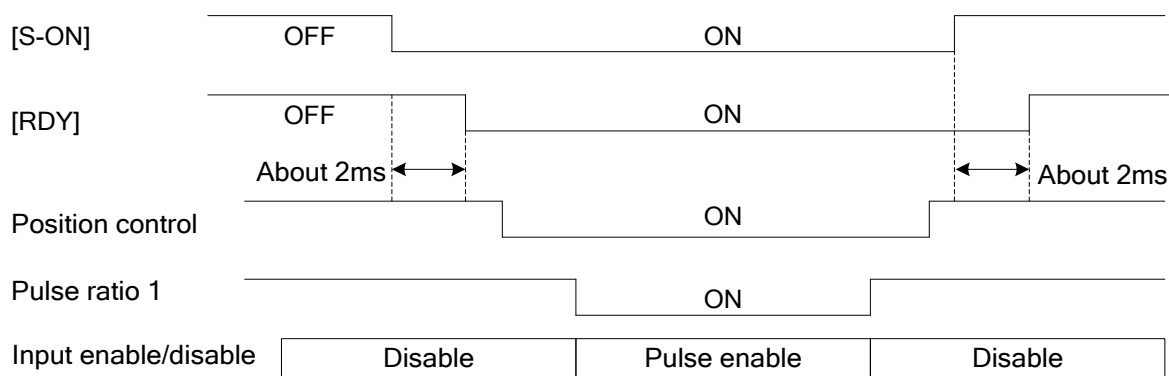

• Command pulse multiplication

Numerator 0 of electronic gear (P1.06), numerator 1 of electronic gear (P2.51), numerator 2 of electronic gear (P2.52) or numerator 3 of electronic gear (P2.53) with an input signal can be selected.

• Position control

The following signals are enabled in the position control mode.

• Zero deviation

The difference between the command position (pulse input) and feedback position (present motor position) is the deviation. The signal is turned on if the present deviation is between a certain value. You can check that the motor has reached the command position.

• Zero speed

It turns ON when the servo motor feedback speed (servo motor current shaft rotation speed) is lower than a certain value

• In-position

Use P1.33 to switch level output and single shot output. Level output is the same to zero deviation signal.

If the zero deviation signal is turned on, single shot output turns ON during a certain period.

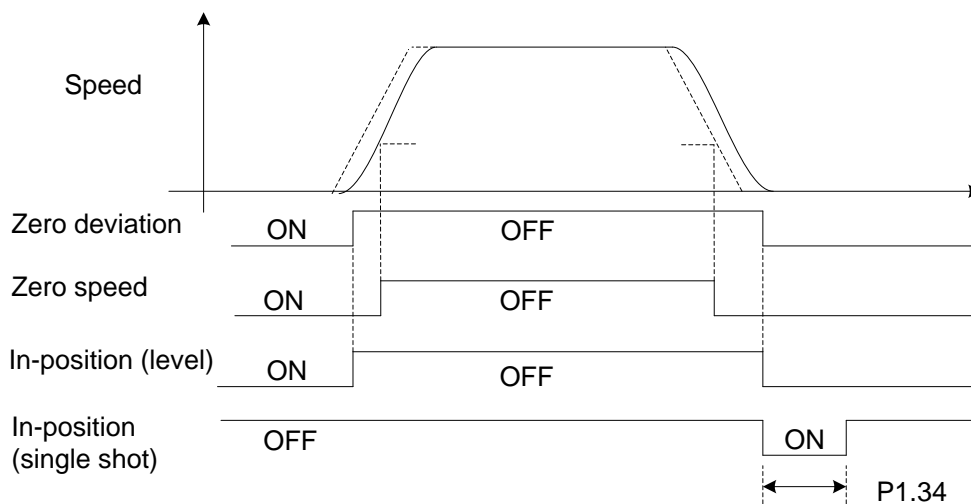

- The single shot output is forcibly turned off if the zero deviation signal is turned off.

- Deviation clear

The difference between the command position (pulse input) and feedback position (present motor position) is the deviation.

Issue a deviation clear signal to zero the internal deviation. The command position becomes the same as the feedback position.

Deviation clear is always effective and active even during rotation.

Either edge or level can be selected with parameter P3.36 to switch the input format of the deviation clear signal.

Because the deviation is forcibly zeroed, the motor is stopped.

4.4.7 Homing

When in-position [INP] is turned on, activation of the homing command [ORG] starts a homing motion.

Enter parameters P2.06 through 18 and 24 to configure the homing pattern.

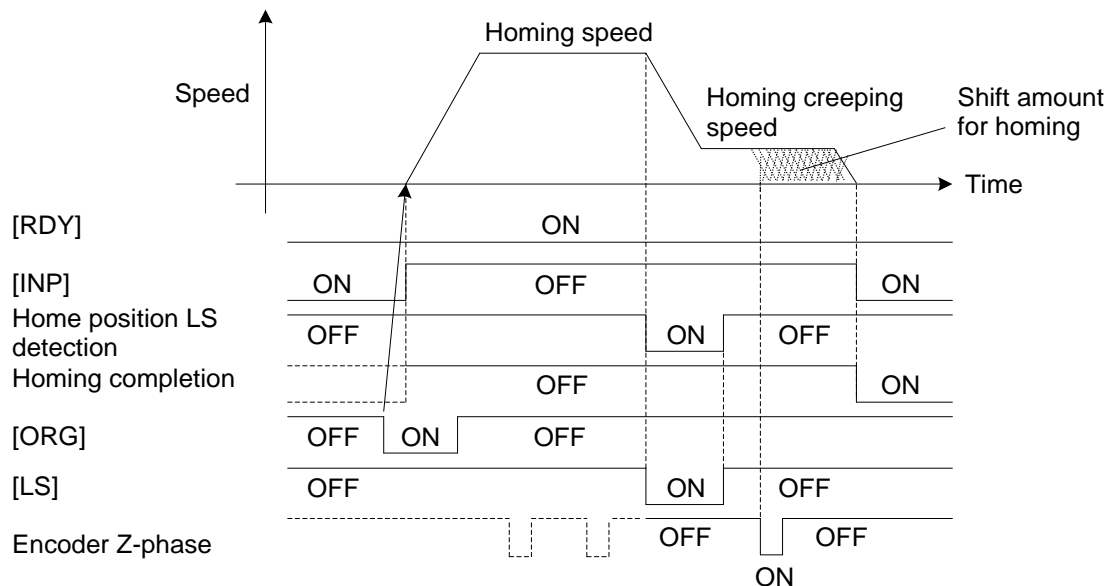

For details of the homing pattern settings, refer to “Chapter 6 description of function parameter”

The homing motion can be interrupted with forced stop [EMG].

Note	<p>The in-position [INP] signal shown in the figure assumes the level output mode.</p> <p>If positioning completion single shot output is selected at the parameter P1.33, check for shortage with an external circuit before executing operation.</p>
-------------	--

4.4.8 Interrupt Positioning

Turn interrupt input enable signal on during operation with a forward [FWD] or reverse [REV] command to start to move by an interrupt traveling unit amount, which is specified at parameter P2.20, at the activating edge (OFF-to-ON transition) of the interrupt output.

Please assign interrupt input enabling and interrupt input to the EI signal.

The function is enabled in the operation with positioning data.

Note: Interrupt input can only be assigned to EI5

(1) Position control, FWD/REV operation

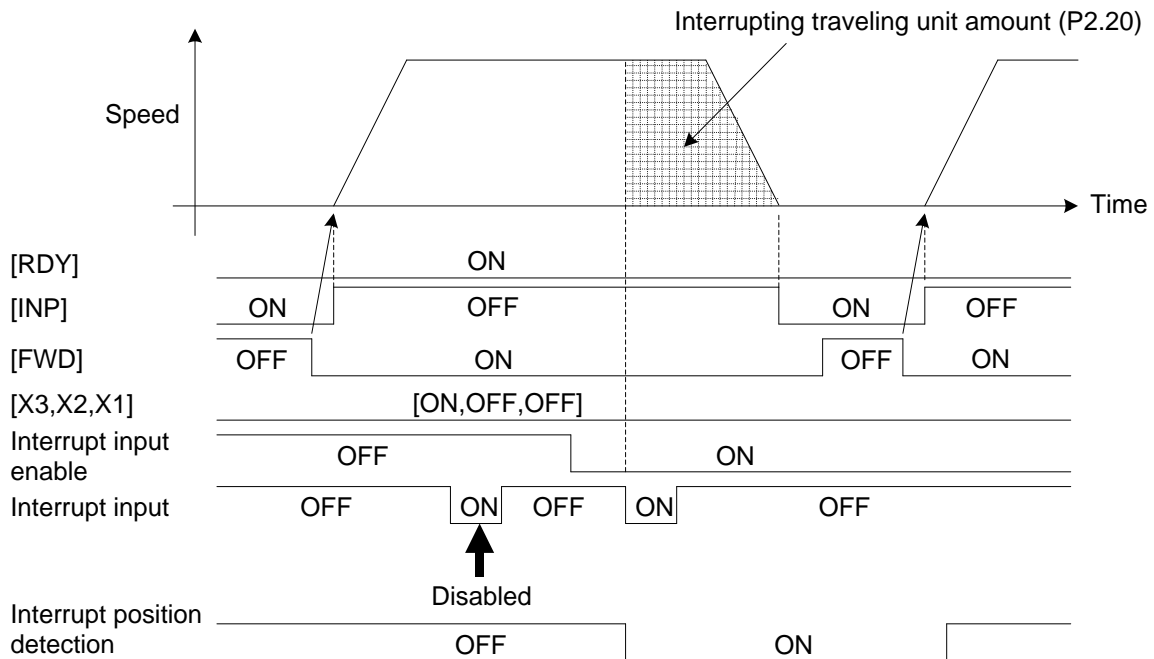

(2) Positioning data operation

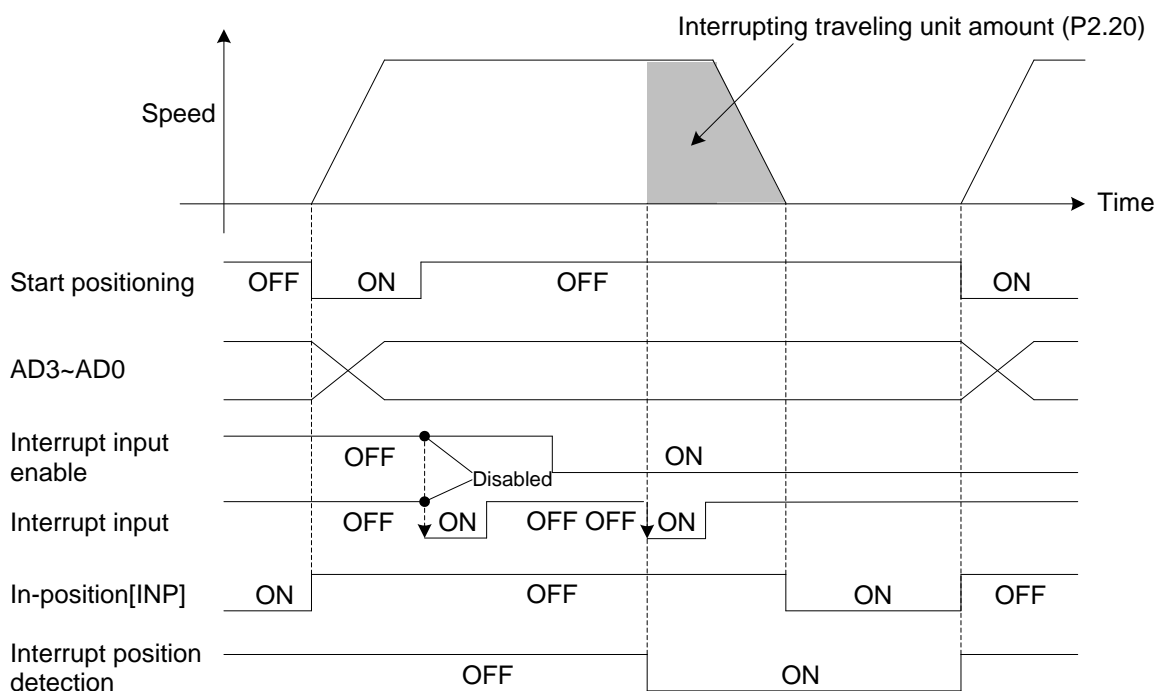

Note	<p>(1) After the interrupt input enable signal is turned on, the activating edge (OFF-to-ON transition) of the first interrupt input is enabled.</p> <p>(2) Allocate the interrupt input to the CN2 terminal of E11~E16.</p> <p>Generally, the external terminal input and output signals are recognized in about 1 to 2ms by the software, however, the interrupt input detects the signals by the hardware. Therefore, delay in signal detection (about 0.05 ms) occurs only with the filter circuit of E11~E18.</p> <p>(3) The in-position [INP] signal shown in the figure assumes the level output mode.</p>
-------------	---

4.4.9 Torque Limit

Torque limit is always enabled in the position control, speed control and torque control mode.

If the torque is limited under position or torque control, the designated position or designated speed may not be achieved.

This function is enabled during positioning data operation.

(1) Position control/speed control

The following limits can be set through combination of the “torque limit 0” and “torque limit 1” sequency inputs.

Torque limit 1	Torque limit 0	Torque limit
OFF	OFF	Value set at P1.27 and P1.28.
OFF	ON	Smaller value between torque command voltage [TREF] and P1.27 (P1.28).
ON	OFF	Smaller value between P1.27 (P1.28) and P2.58.
ON	ON	Smaller value between torque command voltage [TREF] and P2.58.

If neither “torque limit 0” nor “torque limit 1” is used, P1.27, P1.28 are enabled.

(2) Torque control

Forward rotation torque limit P1.27 and reverse rotation torque limit P1.28 are always enabled under torque control.

The output torque is in proportion to the voltage applied at the torque command voltage [TREF] terminal.

(3) Forced stop

The torque limit in forced stop follows parameter P2.60.

4.4.10 Positioning Data Operation

Enter “1” to parameter P2.40 (internal positioning data selection) to perform positioning data operation. PTP (point-to-point) positioning operation is made according to EI/EOUT signals or commands sent via RS-485 communications.

When in-position [INP] is active, enter the desired positioning address (AD0~AD3) and turn start positioning (START) on (activating edge) to execute positioning.

The positioning data can be registered with the PC Loader or keypad (front panel of motor drive) or through teaching. To enable positioning data operation, you can allocate “77”(positioning data selection) to EI signal and turn the signal on.

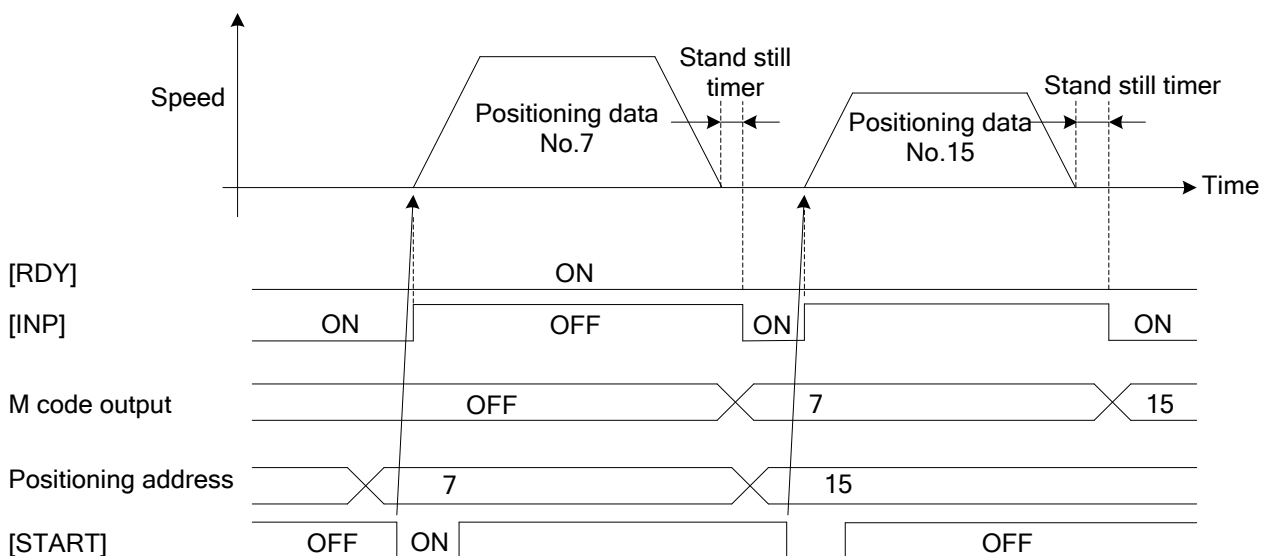

4.4.11 Immediate Value Data Operation

To enable operation with immediate value data, enter “0” to parameter P2.40 (internal positioning, data selection), or enter “1” to that parameter and “3” (immediate value data operation) to parameter P2.41 (sequential start selection). Point-to-point (PTP) positioning operation is made according to commands sent via RS-485 communications. When in-position [INP] is active, enter desired positioning data and so on and turn start positioning (START) on to execute positioning.

To enable immediate value data operation, you can allocate “77” (positioning data selection) to a EI signal and turn the signal off. Use the Modbus-RTU protocol.

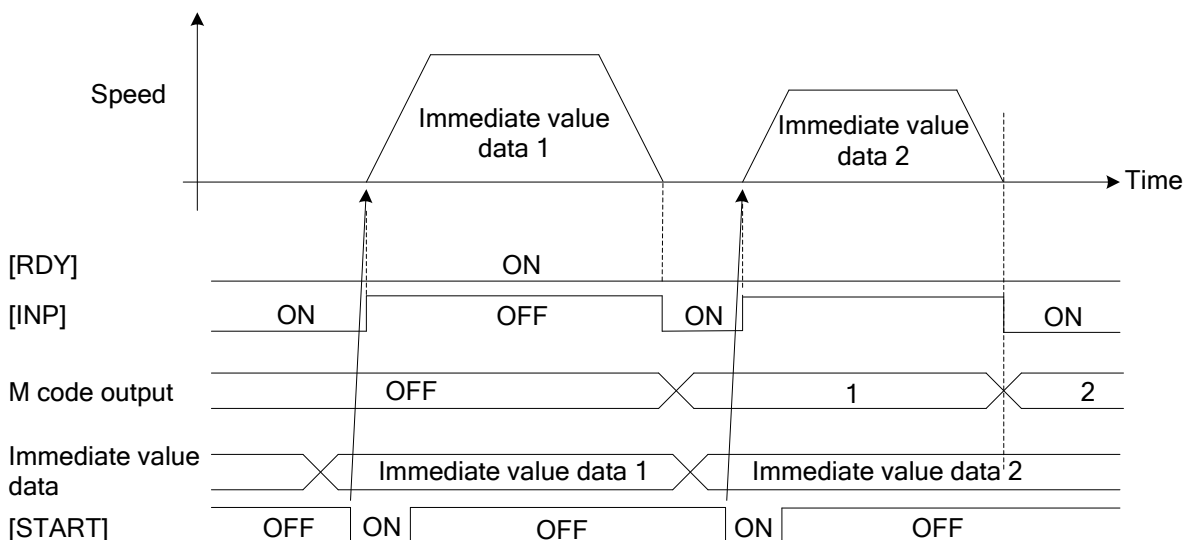

Note	To perform immediate value data operation with the Modbus-RTU protocol in a system consisting of two or more servo system axes, you can use broadcasting to start multiple axes simultaneously, so that pseudo interpolation operation is realized.
-------------	---

4.4.12 Interrupting /Stopping Operation

The following input signals interrupt or stop each operation.

- Servo ON [S-ON]
- +OT/-OT
- Forced stop [EMG]
- Pause
- Positioning cancel
- Deviation clear
- Free-run

(1) Servo ON [S-ON]

If servo-on[S-ON] is turned off during motor rotation, operation is stopped and the motor is stopped according to the setting of the parameter P2.61 (action state at servo-on OFF). If immediate deceleration is selected, deceleration is made at the torque specified in parameter P2.60 (third torque limit).

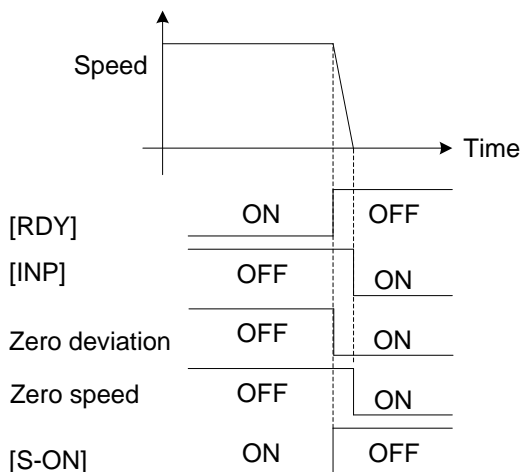

Note	<p>(1) If "free-run at deceleration" is selected at parameter P2.61 (action state at servo-on OFF), the motor coasts for a while due to inertia.</p> <p>(2) The in-position [INP] signal shown in the figure indicates the state in the level output mode.</p> <p>(3) If the forward rotation torque limit (parameter P1.27) or reverse rotation torque limit (parameter P1.28) is smaller than the third torque limit (parameter P2.60), the torque setting of the forward torque limit and reverse torque limit are effective.</p>
-------------	--

(2) +OT/-OT/ positive software OT/ negative software OT

If +OT or -OT is detected during motor rotation (inactive due to normally closed contacts) or positive software OT or negative software OT is detected, operation is stopped and immediate controlled stop is caused according to the torque specified in parameter P2.60 (third torque limit).

·When +OT is detected with hardware

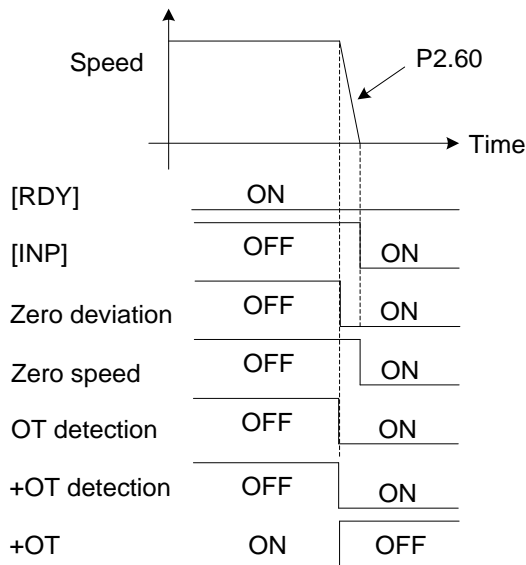

·When +OT is detected with software

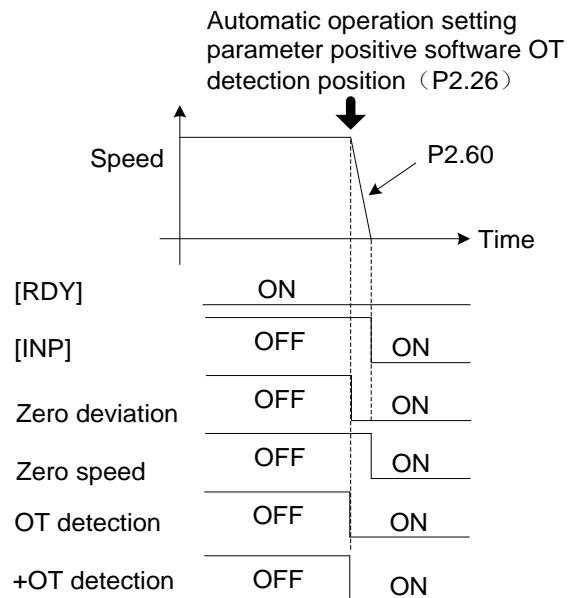

Note	<p>(1)The servo motor does not stop immediately when OT signal is detected at homing.In addition, deceleration follows the setting of parameter P2.18 (selection of operation at OT during homing)</p> <p>(2)The in-position [INP] signal shown in the figure indicates the state in the level output mode.</p> <p>(3)If the forward torque limit (parameter P1.27) or reverse torque limit (parameter P1.28) is smaller than the third torque limit (parameter P2.60), the torque settings of the forward torque limit and reverse torque limit are effective.</p>
-------------	---

(3) Forced stop [EMG]

If forced stop [EMG] is detected during motor rotation, operation is stopped and immediate controlled stop is caused according to the torque specified in parameter P2.60 (third torque limit).

While forced stop [EMG] is detected, the motor is stopped at zero speed and the current position is not retained.

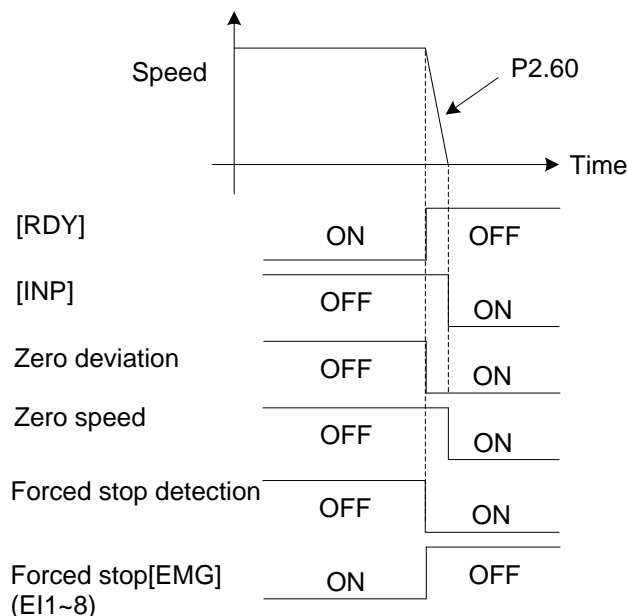

Note	(1) Forced stop [EMG] is normally closed contact signal if it is allocated to EI 1~6 signals.
	(2) The in-position [INP] signal shown in the figure indicates the state in the level output mode.
	(3) If the forward torque limit (parameter P1.27) or reverse torque limit (parameter P1.28) is smaller than the third torque limit (parameter P2.60), the torque settings of the forward torque limit and reverse torque limit are effective.

(4) Pause

If the pause signal is turned on during homing, interrupt positioning, positioning data operation or immediate value data operation, operation is interrupted and the motor is stopped while the signals remains turned on. After the signal is turned off, the operation continues. In-position [INP] is not turned on in a pause.

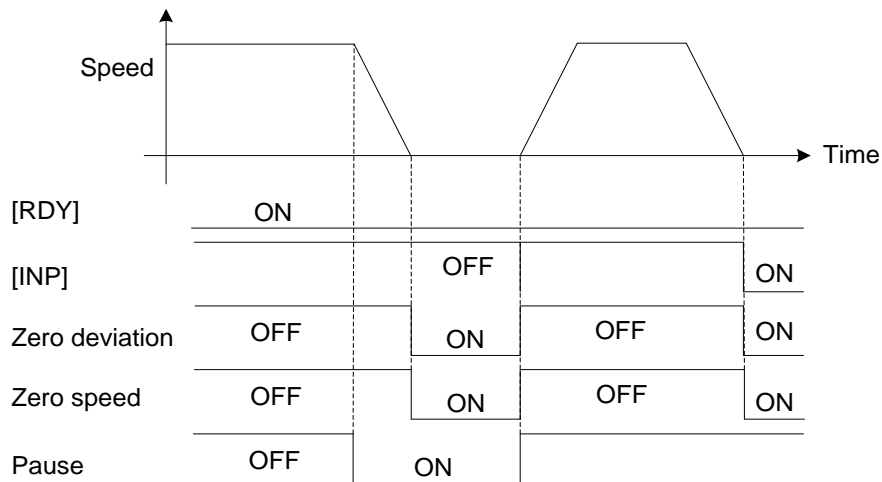

Note	(1) Acceleration/ deceleration follow the settings of parameters P1.37 through 40 and the state of input signal ACC0, or the settings of acceleration/deceleration time data.
	(2) The in-position [INP] signal shown in the figure indicates the state in the level output mode.

(5) Positioning cancel

If the positioning cancel signal is turned on during motor rotation, operation is stopped and controlled stop is caused according to the deceleration time setting. While the positioning cancel signal remains active, homing, interrupt positioning, positioning data operation or immediate value data operation does not start.

The signal is enabled for speed operation and pulse operation.

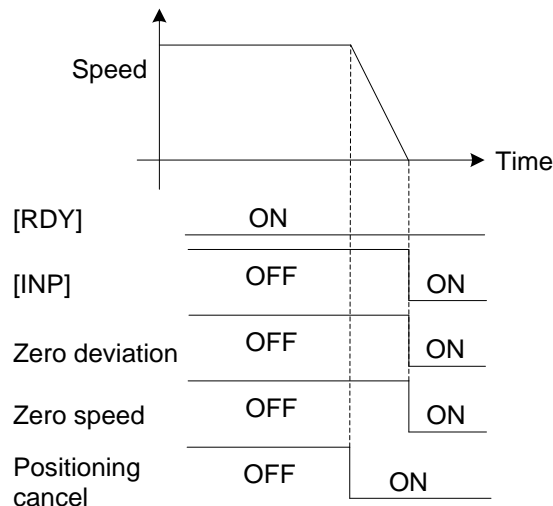

Note	<p>(1)Acceleration/ deceleration follow the settings of parameters P1.37 through 40 and the state of input signal ACC0, or the settings of acceleration/deceleration time data.</p> <p>(2)The in-position [INP] signal shown in the figure indicates the state in the level output mode.</p>
-------------	--

(6) Deviation clear

If the deviation clear signal is detected during motor rotation, operation is stopped and immediate controlled stop is caused according to the selected torque limit. (The maximum torque is assumed if parameter setting is selected with the default setting). If “1”(level signal) is selected for parameter P3.36 (deviation clear input form), the motor is stopped at zero speed and the current position is not retained while the deviation reset signal remains active.

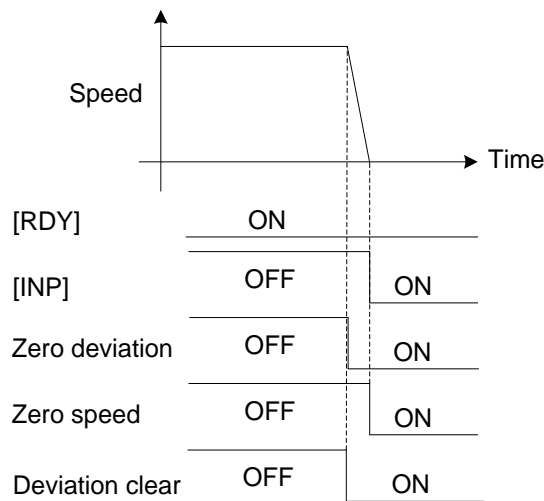

Note	The in-position[INP] signal shown in the figure indicates the state in the level output mode
-------------	--

(7) Free-run

While the free-run signal is turned on, outputs of the servo motor drive are turned off and servo motor coasts to stop (at zero torque). (The motor rotation is not controlled.) If the free-run signal is turned on during motor rotation, operation is stopped and the motor keeps rotating due to the inertia of the load.

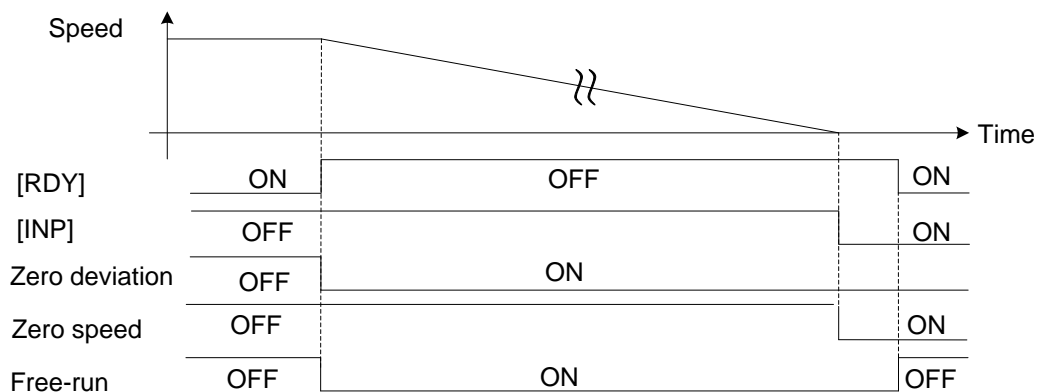

Note	In regular cases, free-run is not used for vertical traveling machines. If the function is used for a vertical traveling machine, examine adaptability with the brake carefully.
-------------	--

In addition to operation stop and interruption caused by input signals, detection of an alarm causes the operation to be stopped. The stopping motion upon an alarm follows the setting of parameter P2.62 (serious alarms: fixed at free-run).

(8) Positive limiter detection/negative limiter detection

If the target position is set with overshooting positive/negative limiter detection value, operation is cancelled before reaching to the target position and stopped at positive/negative limiter detection position.

Limiter detection signals are turned on after the stopping

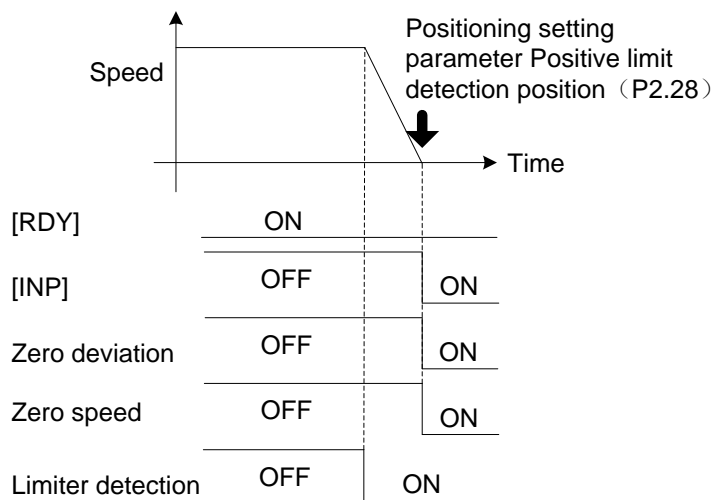

Note	<p>(1)Acceleration/deceleration follows the settings of parameters P1.38 and 40 and the state of input signal ACC0, or the setting of deceleration time data.</p> <p>(2)During pulse operation, the motor is stopped at the limiter detecting position.when the pulse input position reaches the limiter detecting position. The stopping motion follows the torque limit specified in a parameter.</p> <p>(3)The in-position [INP] signal shown in the figure indicates the state in the level output mode.</p>
-------------	--

5 List of Function Parameter

5.1 Parameter Division

⚠ CAUTION

Never add an extreme change to parameters. Otherwise machine motion will become unstable.
Risk of injuries.

Parameters of SDV3 servo motor drive are divided into the following setting items according to the function.

Parameter setting item	Major description
Basic setting parameters (P1.01~50)	Be sure to check or enter these parameters before starting operation.
Control gain and filter setting parameters (P1.51~99)	Use to adjust the gain manually.
Automatic operation setting parameters (P2.01~50)	Use to enter or change the positioning operation speed and homing function.
Extended function setting parameters (P2.51~99)	Use to enter or change the extended function such as the torque limit
Input terminal function setting parameters (P3.01~50)	Use to enter or change input signals of the servo motor drive
Output terminal function setting parameters (P3.51~99)	Use to enter or change output signals of the servo motor drive.

5.2 List of Function Parameter

Note	Parameters marked "○" in the table are enabled in the corresponding control mode.
	Parameters marked "*" in the 1st column of the table indicate that they are enabled only when power on again after parameter setting.

5.2.1 List of Basic Parameter

	Parameter	Name	Default value	Control mode		
				Position	Speed	Torque
*	P1.01	Control mode selection	0	<input type="radio"/>	<input type="radio"/>	<input type="radio"/>
*	P1.02	INC/ABS System Selection	0	<input type="radio"/>	<input type="radio"/>	<input type="radio"/>
*	P1.03	Command pulse input method and form setting	000	<input type="radio"/>	<input type="radio"/>	—
*	P1.04	Rotation direction selection	0	<input type="radio"/>	<input type="radio"/>	<input type="radio"/>
*	P1.05	Number of command input pulses per revolution	0	<input type="radio"/>	<input type="radio"/>	—
	P1.06	Numerator 0 of electric gear	16	<input type="radio"/>	<input type="radio"/>	—
	P1.07	Denominator of electric gear	1	<input type="radio"/>	<input type="radio"/>	—
*	P1.08	Number of command output pulses per revolution	2048	<input type="radio"/>	<input type="radio"/>	<input type="radio"/>
*	P1.09	Numerator of electric gear for output pulses	1	<input type="radio"/>	<input type="radio"/>	<input type="radio"/>
*	P1.10	Denominator of electric gear for output pulses	16	<input type="radio"/>	<input type="radio"/>	<input type="radio"/>
*	P1.11	Output pulse phase selection at CCW rotation	0	<input type="radio"/>	<input type="radio"/>	<input type="radio"/>
*	P1.12	Z-phase position offset	0	<input type="radio"/>	<input type="radio"/>	<input type="radio"/>
	P1.13	Tuning mode selection	10	<input type="radio"/>	<input type="radio"/>	—
	P1.14	Load inertia ratio	1.0	<input type="radio"/>	<input type="radio"/>	—
	P1.15	Auto tuning gain 1	12	<input type="radio"/>	<input type="radio"/>	—
	P1.16	Auto tuning gain 2	4	<input type="radio"/>	—	—
	P1.20	Easy tuning: stroke setting	2.00	<input type="radio"/>	<input type="radio"/>	<input type="radio"/>
	P1.21	Easy tuning: speed setting	500.00	<input type="radio"/>	<input type="radio"/>	<input type="radio"/>
	P1.22	Easy tuning: timer setting	1.500	<input type="radio"/>	<input type="radio"/>	<input type="radio"/>
	P1.23	Easy tuning: direction selection	0	<input type="radio"/>	<input type="radio"/>	<input type="radio"/>
	P1.25	Max. rotation speed (For position and speed control)	Adjust according to the motor model	<input type="radio"/>	<input type="radio"/>	—
	P1.26	Max. rotation speed (For torque control)		—	—	<input type="radio"/>
	P1.27	Forward rotation torque limit	300	<input type="radio"/>	<input type="radio"/>	<input type="radio"/>
	P1.28	Forward rotation torque limit	300	<input type="radio"/>	<input type="radio"/>	<input type="radio"/>
	P1.29	Speed coincidence range	50	<input type="radio"/>	<input type="radio"/>	—
	P1.30	Zero speed range	50	<input type="radio"/>	<input type="radio"/>	<input type="radio"/>
	P1.31	Deviation unit selection	0	<input type="radio"/>	—	—
	P1.32	Zero deviation range/ in-position range	100	<input type="radio"/>	—	—
*	P1.33	In-position output format	0	<input type="radio"/>	—	—
	P1.34	In-position minimum OFF time/Single shot ON time	20	<input type="radio"/>	—	—
	P1.35	In-position judgement time	0	<input type="radio"/>	—	—

Parameter	Name	Default value	Control mode		
			Position	Speed	Torque
P1.36	Acceleration/deceleration selection at speed control	0	—	○	○
P1.37	Acceleration time 1	100.0	○	○	○
P1.38	Deceleration time 1	100.0	○	○	○
P1.39	Acceleration time 2	500.0	○	○	○
P1.40	Deceleration time 2	500.0	○	○	○
P1.41	Manual feed speed 1 for position and speed control/speed limit 1 for torque control	100.00	○	○	○
P1.42	Manual feed speed 2 for position and speed control/speed limit 2 for torque control	500.00	○	○	○
P1.43	Manual feed speed 3 for position and speed control/speed limit 3 for torque control	1000.00	○	○	○
P1.44	Manual feed speed 4 for position and speed control/speed limit 4 for torque control	100.00	○	○	○
P1.45	Manual feed speed 5 for position and speed control/speed limit 5 for torque control	100.00	○	○	○
P1.46	Manual feed speed 6 for position and speed control/speed limit 6 for torque control	100.00	○	○	○
P1.47	Manual feed speed 7 for position and speed control/speed limit 7 for torque control	100.00	○	○	○

5.2.2 List of Parameter Setting (Control Gain, Filter)

Default value: *** Decided by auto-tuning.

Parameter	Name	Default value	Control mode		
			Position	Speed	Torque
P1.51	Moving average S curve time	***	○	—	—
P1.52	Low-pass filter (for S-curve) time constant	0.0	○	○	—
P1.53	Command pulse smoothing function	0	○	—	—
P1.54	Position command response time constant	***	○	—	—
P1.55	Position loop gain 1	***	○	—	—
P1.56	Speed loop gain 1	***	○	○	—
P1.57	Speed loop integration time constant 1	***	○	○	—
P1.58	Feed forward gain 1	0.000	○	—	—
P1.59	Torque filter time constant for position and speed control	***	○	○	—
P1.60	Torque filter time constant for torque control	0.00	—	—	○
P1.61	Gain switch cause	1	○	○	—
P1.62	Gain switch level	50	○	○	—

Parameter	Name	Default value	Control mode		
			Position	Speed	Torque
P1.63	Gain switch time constant	1	○	○	—
P1.64	Position loop gain 2	100	○	—	—
P1.65	Speed loop gain 2	100	○	○	—
P1.66	Speed loop integration time constant 2	100	○	○	—
P1.67	Feed forward gain 2	100	○	—	—
P1.68	Acceleration compensation gain	0	○	—	—
P1.70	Automatic notch filter selection	1	○	○	—
P1.71	Notch filter 1 frequency	4000	○	○	—
P1.72	Notch filter 1 attenuation	0	○	○	—
P1.73	Notch filter 1 width	2	○	○	—
P1.74	Notch filter 2 frequency	4000	○	○	—
P1.75	Notch filter 2 attenuation	0	○	○	—
P1.76	Notch filter 2 width	2	○	○	—
P1.77	Auto vibration suppressing control selection	0	○	—	—
P1.78	Vibration suppressing anti-resonance frequency 0	300.0	○	—	—
P1.79	Vibration suppressing workpiece inertia ratio(Vibration suppressing resonance frequency) 0	0	○	—	—
P1.80	Vibration suppressing anti-resonance frequency 1	300.0	○	—	—
P1.81	Vibration suppressing workpiece inertia ratio (Vibration suppressing resonance frequency) 1	0	○	—	—
P1.82	Vibration suppressing anti-resonance frequency 2	300.0	○	—	—
P1.83	Vibration suppressing workpiece inertia ratio(Vibration suppressing resonance frequency) 2	0	○	—	—
P1.84	Vibration suppressing anti-resonance frequency 3	300.0	○	—	—
P1.85	Vibration suppressing workpiece inertia ratio (Vibration suppressing resonance frequency) 3	0	○	—	—
P1.86	Vibration suppressing damping coefficient	0.0000	○	—	—
P1.87	Model torque filter time constant	***	○	○	—
P1.88	Position loop integration time constant	***	○	—	—
P1.89	Position loop integration limiter	0	○	—	—
P1.90	Load torque observer	0	○	○	—
P1.91	P/PI auto-switch selection	0	○	○	—
P1.92	Speed range for friction compensation	10.0	○	○	—
P1.93	Coulomb friction torque for friction compensation	0	○	○	—
P1.94	Torque filter setting mode	1	○	○	—
P1.95	Model torque calculation selection/Speed observer selection	3	○	○	—
P1.96	Speed limit gain for torque control	4.0	—	—	○

5.2.3 List of Parameter Setting (Auto-operation)

	Parameter	Name	Default value	Control mode		
				Position	Speed	Torque
	P2.01	Decimal point position of positioning data	0	○	○	○
	P2.06	Homing speed	500.00	○	—	—
	P2.07	Homing creeping speed	50.00	○	—	—
*	P2.08	Starting direction for homing	0	○	—	—
	P2.09	Reverse traveling unit amount for homing	0	○	—	—
*	P2.10	Homing direction	0	○	—	—
*	P2.11	Reference signal for shift operation	1	○	—	—
*	P2.12	Reference signal for homing	0	○	—	—
*	P2.13	Home position LS signal edge selection	0	○	—	—
	P2.14	Home position shift unit amount	1000	○	—	—
*	P2.15	Deceleration operation for creep speed	0	○	—	—
	P2.16	Home position after homing completion	0	○	—	—
	P2.17	Home position detection range	0	○	—	—
	P2.18	Deceleration time at OT during homing	100.0	○	—	—
	P2.19	Preset position	0	○	—	—
	P2.20	Interrupt traveling unit amount	100000	○	—	—
	P2.22	Detection time for contact-stopper	0	○	—	—
	P2.23	Torque limit for contact-stopper	0	○	—	—
*	P2.24	Selection of operation at OT during homing	0	○	—	—
*	P2.25	Software OT selection (P1.01=1 to 6) / Position command format (P1.01=7)	0	○	○	—
	P2.26	Positive software OT detection position	2000000 000	○	○	—
	P2.27	Negative software OT detection position	-200000 0000	○	○	—
	P2.28	Positive limiter detection position	2000000 000	○	—	—
	P2.29	Negative limiter detection position	-200000 0000	○	—	—
	P2.31	Point detection, area detection	0	○	○	○
	P2.32	Point detection, area detection position 1	0	○	○	○
	P2.33	Point detection area detection position 2	0	○	○	○
	P2.34	Point detection range	100	○	○	○

	Parameter	Name	Default value	Control mode		
				Position	Speed	Torque
	P2.36	Override 1	10	○	○	—
	P2.37	Override 2	20	○	○	—
	P2.38	Override 4	40	○	○	—
	P2.39	Override 8	80	○	○	—
*	P2.40	Internal positioning data selection	0	○	○	—
*	P2.41	Sequential start selection	0	○	—	—
	P2.42	Decimal point position of stand still timer	0	○	—	—
*	P2.43	Output selection at M code OFF	1	○	—	—
*	P2.44	Positioning extended function	0	○	—	—

5.2.4 List of Extended Function Setting Parameter

	Parameter	Name	Default value	Control mode		
				Position	Speed	Torque
	P2.51	Numerator 1 of electronic gear	1	○	○	—
	P2.52	Numerator 2 of electronic gear				
	P2.53	Numerator 3 of electronic gear				
	P2.54	Command pulse ratio 1	1.00	○	—	—
	P2.55	Command pulse ratio 2	10.00	○	—	—
*	P2.56	Speed limit selection at torque control	0	—	—	○
*	P2.57	Torque limit selection	0	○	○	—
	P2.58	Second torque limit	300	○	○	—
*	P2.59	Deviation hold selection at torque limit	0	○	—	—
	P2.60	Third torque limit	300	○	○	—
*	P2.61	Action state at servo-on OFF	5	○	○	○
*	P2.62	Action state at alarm	5	○	○	○
*	P2.63	Action state at main power shutoff	5	○	○	○
	P2.64	Torque keeping time to holding brake	0.00	○	○	○
	P2.65	Reserved	1	—	—	—
*	P2.66	Flying start at speed control	0	—	○	—
*	P2.67	Alarm detection at undervoltage	1	○	○	○
	P2.69	Deviation detection overflow value	15.0	○	—	—
	P2.70	Overload warning value	50	○	○	○
*	P2.72	Station number	1(RS485)	○	○	○

	Parameter	Name	Default value	Control mode		
				Position	Speed	Torque
*	P2.73	Communication baud rate (RS-485)	0	○	○	○
	P2.74	Parameter write protection	0	○	○	○
	P2.75	Positioning data write protection	0	○	—	—
*	P2.77	Initial display of the keypad	0	○	○	○
	P2.78	Reserved	0	—	—	—
*	P2.80	Parameter in RAM 1	0	○	○	○
	P2.81	Parameter in RAM 2				
	P2.82	Parameter in RAM 3				
	P2.83	Parameter in RAM 4				
	P2.84	Parameter in RAM 5				
	P2.85	Parameter in RAM 6				
*	P2.86	Positioning data in RAM 1	0	○	—	—
*	P2.87	Positioning data in RAM 2	0	○	—	—
*	P2.88	Positioning data in RAM 3	0	○	—	—
*	P2.89	Sequence test mode: mode selection	0	○	○	○
*	P2.90	Sequence test mode: encoder selection	0	○	○	○
*	P2.93	Parity/stop bit selection	0	○	—	—
	P2.94	Response time	0.00	○	—	—
	P2.95	Communication time over	0	○	—	—
	P2.97	Communication protocol selection	1	○	—	—
*	P2.99	Encoder selection	1	○	○	○

5.2.5 List of Parameter Setting (Input terminal function)

	Parameter	Name	Default value	Control mode		
				Position	Speed	Torque
*	P3.01	E11 signal assignment	1	○	○	○
	P3.02	E12 signal assignment	11			
	P3.03	E13 signal assignment	0			
	P3.04	E14 signal assignment	0			
	P3.05	E15 signal assignment	0			
	P3.09	Communication E19 signal assignment	0			
	P3.10	Communication E110 signal assignment	0			
*	P3.11	Communication E111 signal assignment	0	○	○	○

	Parameter	Name	Default value	Control mode		
				Position	Speed	Torque
	P3.12	Communication EI12 signal assignment	0			
	P3.13	Communication EI13 signal assignment	0			
	P3.14	Communication EI14 signal assignment	0			
	P3.15	Communication EI15 signal assignment	0			
	P3.16	Communication EI16 signal assignment	0			
	P3.17	Communication EI17 signal assignment	0			
	P3.18	Communication EI18 signal assignment	0			
	P3.19	Communication EI19 signal assignment	0			
	P3.20	Communication EI20 signal assignment	0			
*	P3.21	Communication EI21 signal assignment	0	○	○	○
	P3.22	Communication EI22 signal assignment	0			
	P3.23	Communication EI23 signal assignment	0			
	P3.24	Communication EI24 signal assignment	0			
	P3.25	Virtual EI input	0			
	P3.26	EI always on 1	0			
	P3.27	EI always on 2	0			
	P3.28	EI always on 3	0			
	P3.29	EI always on 4	0			
	P3.30	EI always on 5	0			
	P3.31	Speed command scale	5.0	○	○	○
	P3.32	Speed command offset	Factory default	○	○	○
	P3.33	Torque command scale	3.0	○	○	○
	P3.34	Torque command offset	Factory default	○	○	○
	P3.35	Zero clamp level	0	○	○	—
*	P3.36	Deviation clear input format	0	○	—	—
	P3.39	Speed command fine adjustment gain	1.0000	○	○	○
	P3.40	Torque command fine adjustment gain	1.0000	○	○	○
	P3.42	Command pulse filter setting	3	○	○	—
	P3.49	VREF filter time constant	0.50	○	○	○
	P3.50	TREF filter time constant	0.50	○	○	○

5.2.6 List of Parameter Setting (Output terminal function)

	Parameter	Name	Default value	Control mode		
				Position	Speed	Torque
	P3.51	EOUT 1 signal assignment	1			
	P3.52	EOUT 2 signal assignment	2			
	P3.53	EOUT 3 signal assignment	76			
	P3.56	Communication EOUT 6 signal assignment	0			
	P3.57	Communication EOUT 7 signal assignment	0			
	P3.58	Communication EOUT 8 signal assignment	0			
	P3.59	Communication EOUT 9 signal assignment	0			
	P3.60	Communication EOUT 10 signal assignment	0			
	P3.61	Communication EOUT 11 signal assignment	0			
*	P3.62	Communication EOUT12 signal assignment	0	○	○	○
	P3.63	Communication EOUT13 signal assignment	0			
	P3.64	Communication EOUT14 signal assignment	0			
	P3.65	Communication EOUT15 signal assignment	0			
	P3.66	Communication EOUT16 signal assignment	0			
	P3.67	Communication EOUT17 signal assignment	0			
	P3.68	Communication EOUT18 signal assignment	0			
	P3.69	Communication EOUT19 signal assignment	0			
	P3.70	Communication EOUT20 signal assignment	0			
	P3.71	Communication EOUT21 signal assignment	0			
*	P3.90	Servo motor model setting	00	○	○	○
	P3.92	Range 1 of position: Setting 1	0	○	—	—
	P3.93	Range 1 of position: Setting 2	0	○	—	—
	P3.94	Range 2 of position: Setting 1	0	○	—	—
	P3.95	Range 2 of position: Setting 2	0	○	—	—

5.2.7 Application Function Parameters

	Parameter	Name	Default value	Control mode		
				Position	Speed	Torque
	P4.20	Position deviation exceeds timeout value	00	○	—	—
	P4.21	Speed out-of control level	1000	○	○	—
	P4.22	Speed out-of control timeout value	3000	○	○	—
	P4.25	Homing timeout value	0	○	—	—
	P4.69	Brake release delay time after SON	0.00	○	○	○

6 Detail Description of Function Parameter

6.1 Basic Setting Parameters (P1.01~50)

◆ The parameters with “*” indicate that they are enabled only when power on again after parameter setting.

*P1.01	Control mode selection	Default value	0
	Setting range	0: Position 3: Position↔Speed 6: Extension mode 1: Speed	4: Position↔Torque 7: Positioning operation 2: Torque 5: Speed↔Torque

 Specify the desired control mode in the parameter with a value.

To switch during operation, change over the control mode selection of the EI input signal (Function NO.36).

For details, refer to the below table:

P1.01: Control mode selection Setting value	Control mode	
	Control mode selection =OFF	Control mode selection =ON
0	Position control	
1	Speed control	
2	Torque control	
3	Position control	Speed control
4	Position control	Torque control
5	Speed control	Torque control
6	Extension mode	
7	Positioning operation mode	

(1) If P1.01 (control mode selection) is between 0 and 5

Change over the control mode selection (function NO.36) to change the control mode even during operation.

Position control can be made only during pulse operation.

[Example] The operation pattern of control mode selection 3 (position↔ speed) is shown in the figure below.

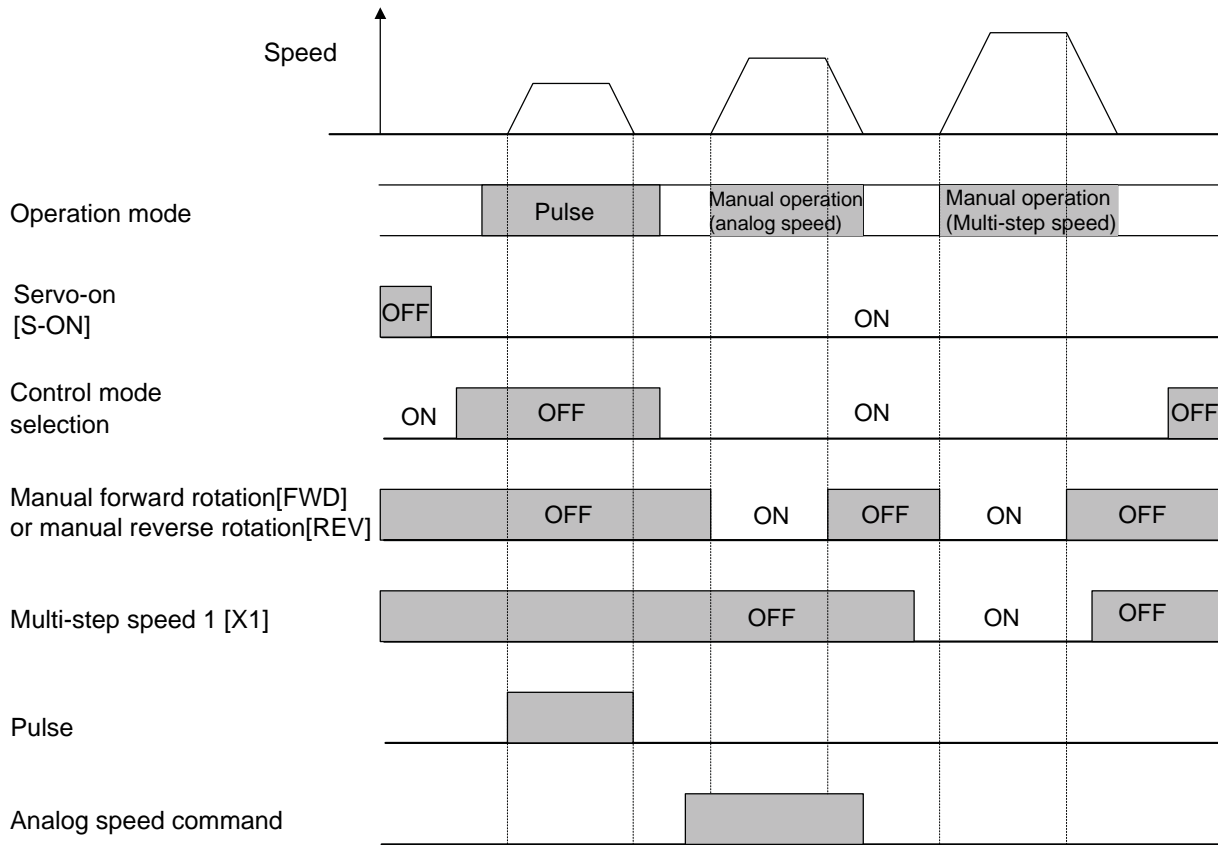

(2) If P1.01 (control mode selection) is 6

The power-on state is the speed control mode (see the figure below).

To perform homing and interrupt positioning, select this mode.

Speed control

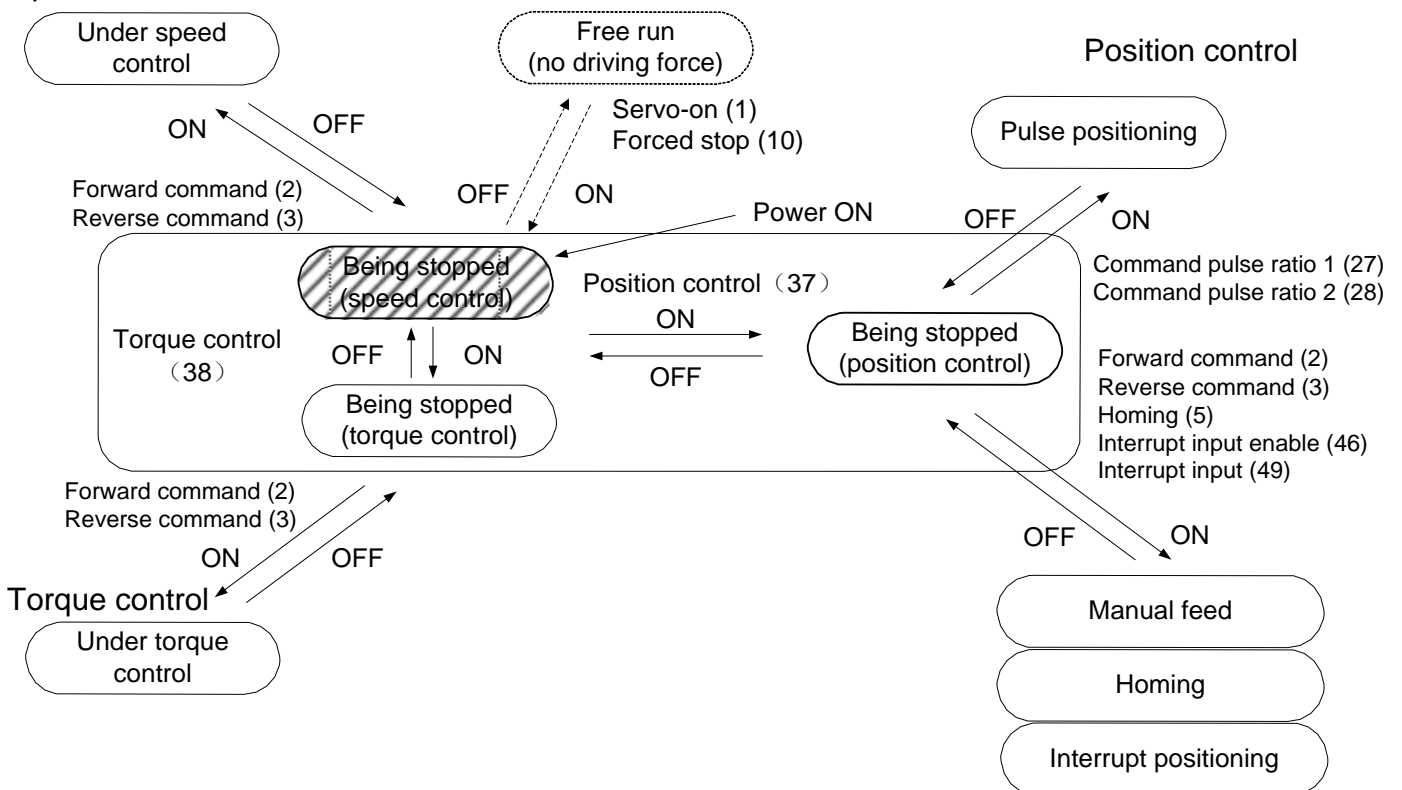

(3) If P1.01 (positioning operation mode selection) is "7"

Positioning (positioning data operation, immediate value data operation and homing) can be made.

The position control mode is selected immediately after the power is turned on (see the figure below).

Speed control

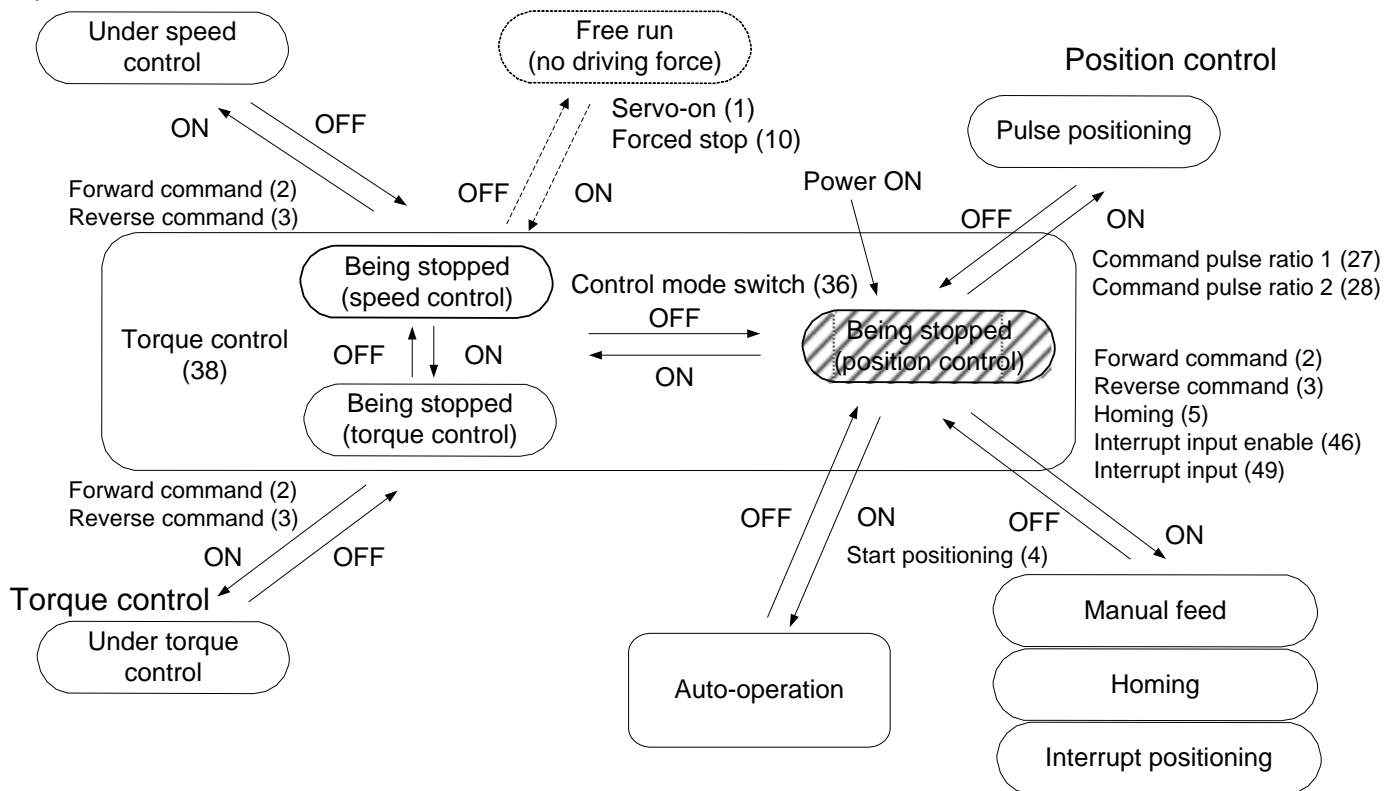

*P1.02	INC/ABS system selection	Default Value	0
	Setting Range	0: Incremental system 1: Absolute system 2: Non-overflow absolute system (not detect the multi-turn overflow)	

Select either the relative position (incremental) system or absolute position system.

Reference value	Function	Description
0	Relative position (incremental) system	The current position is lost after the power is turned off. Homing must be performed again.
1	Absolute position system	The current position is stored in memory even after the power is turned off. Homing is unnecessary. You can operate in the limited range. If the operation range is exceeded, an alarm and stoppage are caused. (Operation range: between -32767 and +32766 revolutions of motor shaft)
2	Non-overflow absolute system (not detect the multi-turn overflow)	The current position is stored in memory even after the power is turned off. Homing is unnecessary. Because there is no limit in the operation range, this system is best for the control of the rotating body. (The multi-turn data over flow alarm is not detected.) Multi-rotation data should be processed at the host controller suitably.

 To establish an absolute position system, set this parameter at "1" or "2." In addition, install the optional absolute backup battery.

Because a multi-turn data over flow alarm (dL1 alarm) is detected when the power is turned on, perform position presetting to remove the alarm and start operation.

*P1.03	Command pulse input method and form selection and input source selection		Default value	000
	Setting range	Lower 2 bits: 00: Differential, command pulse / symbol 01: Differential, forward / reverse pulse 02: Differential, A / B phase pulse signal 03: Open collector, command pulse / symbol 04: Open collector, forward pulse / reverse pulse 05: Open collector, A / B phase pulse signal Highest bit: 0: Normal command pulse direction 1: Reverse command pulse direction		

 This parameter is enabled only under position control and speed control.

You can select the signal format of command pulse input terminal.

The pulse format of command pulse input terminals [SIGN+], [SIGN-], [PULS+], and [PULS-] of the servo motor drive can be specified.

The maximum input frequency is 500 [KHz] at differential input or 200 [kHz] at open collector input.

In case of A/B phase pulse, the rising or falling edge of the A-phase signal or B-phase signal is counted as a single pulse, so that a single-pulse input is equivalent to four pulse counts.

*P1.04	Rotation direction selection		Default value	0
	Setting range	0: CCW rotation at forward command 1: CW rotation at forward command		

 The parameter keeps consistency between the direction of rotation of the servo motor and the traveling direction of the machine.

The servo motor rotates forward if it rotates counterclockwise (CCW: figure on the right) when the output shaft is viewed from the front. Clockwise rotation is reverse rotation.

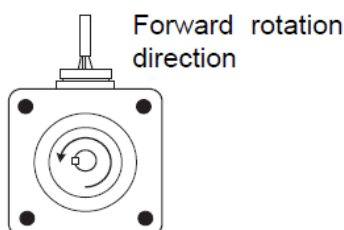

*P1.05	Number of command input pulses per revolution	Default value	0
	Setting range	0: Electronic gear (P1.06/07) is enabled 64~1048576 [pulse]: This parameter setting is enabled	

 The parameter is enabled only under position control and speed control.

Enter the number of command pulses necessary to rotate the servo motor a full turn.

When the default value ("0"), the settings of P1.06 and 07 (electronic gear numerator and denominator) are enabled.

P1.06	Numerator 0 of electric gear	Default value	16
P1.07	Denominator of electric gear	Default value	1
	Setting range	1~4194304	

 These parameters are enabled only under position control and speed control.

With these parameters, the traveling amount of the mechanical system per each command pulse is adjusted to a unit amount.

Calculate according to the following equation:

· Equation of numerator 0 of electronic gear and denominator of electronic gear

Cancel down so that numerator 0 divided by the denominator of the electronic gear is an integer (65535 or less).

$$\frac{\text{Traveling amount of the mechanical system per servo motor revolution}}{\text{Number of encoder pulses}} \times \frac{\text{Numerator 0 of electric gear}}{\text{Denominator of electric gear}} = \text{unit amount}^*$$

* The unit amount is the machine travel amount to one command pulse. Its unit is [unit].

(mm/pulse, degree/pulse=[unit])

$$\frac{\text{Numerator 0 of electric gear}}{\text{Denominator of electric gear}} = \frac{\text{Number of encoder pulses}}{\text{Traveling amount of the mechanical system per servo motor revolution}} \times \text{unit amount}$$

【Calculation example of electronic gear】

To connect the ball screw (lead 10 mm) directly to the output shaft of the servo motor and set the unit amount at 1/100, the number of encoder pulses (17 bits) is 131072 rev

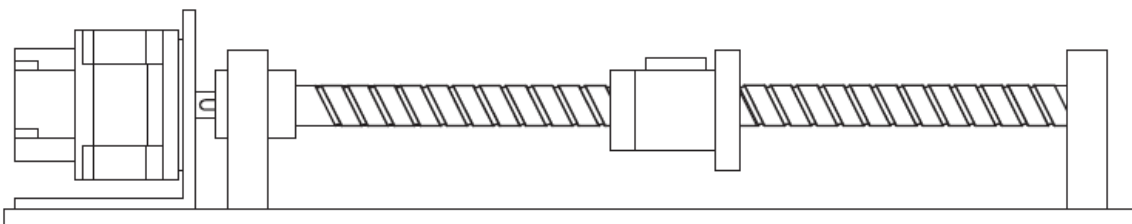

$$\frac{\text{Traveling amount of the mechanical system per servo motor revolution}}{131072/\text{rev}} \times \frac{\text{Numerator 0 of electric gear}}{\text{Denominator of electric gear}} = \text{unit amount}$$

$$\frac{10\text{mm}}{131072/\text{rev}} \times \frac{\text{Numerator 0 of electric gear}}{\text{Denominator of electric gear}} = 1/100$$

$$\frac{\text{Numerator 0 of electric gear}}{\text{Denominator of electric gear}} = \frac{131072/\text{rev}}{10\text{mm}} \times \frac{1}{100} = \frac{16384}{125}$$

Therefore, numerator 0 and denominator of the electronic gear are 16384 and 125, respectively.

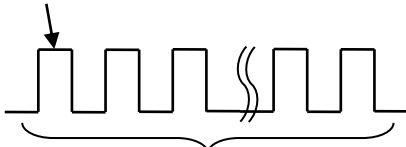
Tips	<p>If the traveling amount of the mechanical system per servo motor revolution includes π, you can approximate to 355/113.</p> <p>The number of output pulses is irrelevant to command pulse correction.</p> <p>Compliant with P1.08: Set value of the number of output pulses per revolution.</p> <p style="text-align: center;">0.01 mm per pulse</p>  <p style="text-align: center;">10 mm per 1000 pulses (One full motor revolution)</p>
-------------	---

*P1.08	Number of command output pulses per revolution	Default value	2048
	Setting range	0: Electronic gear (P1.09/10) is enabled 16~262144 [pulse]: This parameter setting is enabled	

 Enter the number of pulses output per motor rotation from pulse output terminal (A-phase or B-phase).

As the output format applies A/B phase pulse, the setting range is set as follows: 17-bit motor: 16 to 32768 pulses.

If the reference value is other than 0, the Z-phase output synchronizes with the A-phase output, and an output having the same pulse width as that of the A-phase is obtained.

With default value "0," settings of parameters P1.09 and P1.10 are followed.

*P1.09	Numerator of electric gear for output pulses	Default value	1
	Setting range	1~4194304	
*P1.10	Denominator of electric gear for output pulses	Default value	16
	Setting range	1~4194304	

 Specify the ratio of the output pulse per revolution of the servomotor.

Calculate according to the following equation.

- In case of a 17-bit encoder, specify "1/16" to output 2048 (32768 x 1/16) A-phase and B-phase pulses per revolution.
- The Z-phase output is issued asynchronously to the A- and B-phases at a constant pulse width of 125 μ s. Enter parameters so that P1.09 \leq P1.10. If P1.09 > P1.10, the division ratio is 1.

*P1.11	Output pulse phase selection at CCW rotation	Default value	0
	Setting range	0: A-phase pulse lead at CCW rotation 1: B-phase pulse lead at CCW rotation	

The phase of the output pulse of the servo motor is adjusted to the traveling direction of the machine.

Select the phase of forward rotation (CCW rotation) of the servo motor.

The pulse is output at connector CN2 (OA+,OA-,OB+,OB-).

·If the reference value is 0

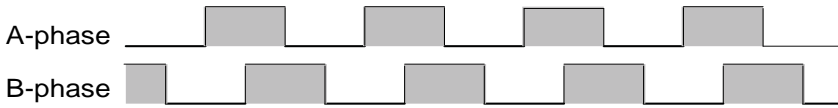

·If the reference value is 1

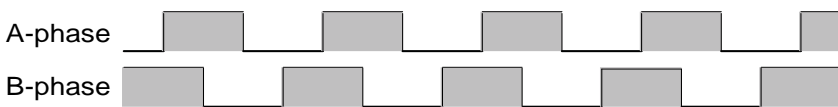

*P1.12	Z-phase position offset	Default value	0
	Setting range	20bitPG: 0~1048575 17bitPG: 0~131071	

The Z-phase output position shifts. The Z-phase output position shifts in the CCW direction by the specified pulse amount.

This parameter is irrelevant to the rotation direction selection (parameter P1.04).

The Z-phase used for homing is also the position that is offset with this parameter.

·Z-phase output position (17-bit encoder)

If the Z-phase position offset is 0

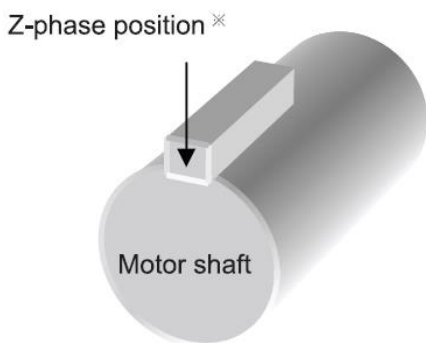

If the Z-phase position offset is 32768

$$\frac{32768 \text{ pulses}}{131072 \text{ pulses/rev}} = 0.25 \text{ rev}$$

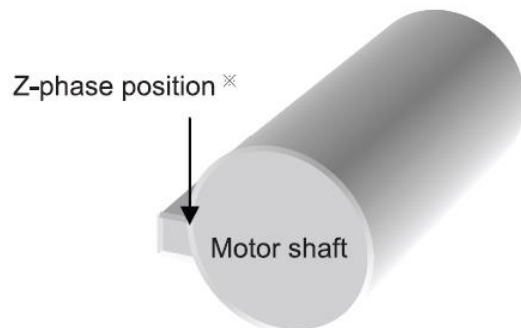

※The position of the key is not always the Z-phase position.

The position of the key is supposed to be the Z-phase position in this explanation.

P1.13	Tuning mode selection		Default value	10
	Setting range	10: Auto tuning 11: Semi-auto tuning 12: Manual tuning 13: Interpolation operation mode 14: Trace operation mode 15: Shorter cycle time operation mode		

 This parameter is enabled under position and speed control.

Select the tuning method of the servo motor drive. Refer to the following description to select the mode.

▪ **Auto tuning(Default value)**

In this mode, the ratio of moment of inertia of the load of the machine is always assumed inside the servo motor drive and the gain is automatically adjusted to the best one.

▪ **Semi-auto tuning**

Use this mode if the ratio of moment of inertia of the load of the machine has relatively large fluctuation or the ratio of moment of inertia of the load is not estimated correctly inside the servo motor drive.

The gain is automatically adjusted to the best one in relation to the setting of P1.15 (auto tuning gain 1), P1.16 (auto tuning gain 2), and P1.14 (load inertia ratio).

▪ **Manual tuning**

Use this mode if auto tuning and semi-auto tuning modes do not function satisfactorily.

Manually enter the ratio of moment of inertia of the load and various gains.

▪ **Interpolation operation mode**

Use this mode to adjust responses of each shaft to the command during interpolation of two or more servo motor axes of an X-Y table or similar.

In this mode, P1.51 (moving average S-curve time) and P1.54 (position command response time constant) that determine the following characteristics to commands must be entered manually.

As well, P1.14 (load inertia ratio) must be entered, too, manually.

The other gain adjustment parameters are automatically entered according to the value of P1.15 (auto tuning gain 1).

▪ **Trace operation mode**

Use this mode to adjust responses of each shaft to the command during trace control of two or more servomotor axes of an X-Y table or similar.

In this mode, P1.14 (load inertia ratio) and P1.51 (moving average S-curve time) must be entered manually.

As well, the parameter P1.95 is set to "0" (model torque calculation is disabled/speed observer is disabled).

P1.54 (position command response time constant) is enabled only when P1.58 (feed forward gain 1) is set to other than 0.000.

As well, P1.14 (load inertia ratio) must be entered, too, manually.

The other gain adjustment parameters are automatically entered according to the value of P1.15 (auto tuning gain 1).

▪ **Shorter cycle time operation mode**

Use this mode to improve tact (reduce the settling time) on a machine with high rigidity such as a ball screw.

P1.14 (load inertia ratio) must be entered manually.

The other gain adjustment parameters are automatically entered according to the values of P1.15 (auto tuning gain 1) and P1.16 (auto tuning gain 2).

Parameters that must be entered in each tuning mode and automatically adjusted parameters are shown below.

Parameters	Name	Tuning mode					
		10: Auto	11: Semi-auto	12: Manual	13: Interpolation	14: Trace	15: Shorter cycle time
P1.14	Load inertia ratio	—	○	○	○	○	○
P1.15	Auto tuning gain 1	○	○	×	○	○	○
P1.51	Moving average S-curve time	—	—	○	○	○	—
P1.54	Position command response time constant	—	—	○	○	○	—
P1.55	Position loop gain 1	—	—	○	—	—	—
P1.56	Speed loop gain 1	—	—	○	—	—	—
P1.57	Speed loop integration time constant 1	—	—	○	—	—	—
P1.59	Torque filter time constant for position and speed control	△	△	○	△	△	△
P1.87	Model torque filter time constant for position	△	△	○	△	×	△
P1.88	Position loop integration time constant	—	—	○	—	—	—

○: Items that must be entered.

△: The item is entered automatically or manually according to a parameter (P1.94: torque filter setting mode).

—: Entry is unnecessary. (The item is automatically calculated inside the amplifier and the result is reflected on the parameter.)

×: Entry can be made, but the setting is ineffective.

P1.14	Load inertia ratio	Default value	1.0
	Setting range	0.0~300.0	

 This parameter is enabled under position and speed control.

Enter the moment of inertia of the load of the mechanical system in relation to the motor shaft (moment of inertia of load converted to motor shaft) in a ratio to the moment of inertia of the motor.

$$\text{Load inertia torque ratio} = \frac{\text{Servo motor shaft conversion load inertia torque}}{\text{Servo motor inertia torque}}$$

The parameter must be entered according to some settings of P1.13 (tuning mode selection).

With auto tuning, the value is automatically updated and saved in EEPROM every 10 minutes.

The value must be entered in the mode other than auto tuning.

How to enter the ratio of inertia of load

(1) Entering the value monitored on display

Use the monitor mode dP-14 of the display to monitor.

Enter the monitored value.

- If the value drifts, enter an average value.

If fluctuation is substantial and the ratio of the maximum to the minimum exceeds two, adopt entry method (2).

(2) Entering the calculated value

Calculate the moment of inertia of load converted to the motor shaft and enter the ratio to the moment of inertia of the motor.

P1.15	Auto tuning gain 1	Default value	12
	Setting range	1~40	

 This parameter is enabled under speed and position control.

Specify the response of the servo motor in the mode other than manual tuning.

While a larger setting shortens command following characteristic and positioning settling time, too large a value causes vibration of the servo motor.

·Setting method

(1) Parameter entry with keypad (parameter setting mode)

After the parameter is established, the setting is updated.

(2) Entry using "auto tuning gain setting (AF-11)" of keypad (additional function mode)

After the value is switched, the setting is updated at real time.

Approximate reference value

Mechanical configuration (division by mechanism)	Auto tuning gain 1 (approximate reference value)
Large transfer machine	1~10
Arm robot	5~20
Belt mechanism	10~25
Ball screw + Belt mechanism	15~30
Mechanism directly coupled with ball screw	20~40

P1.16	Auto tuning gain 2	Default value	4
	Setting range	1~12	

 This parameter is enabled only under position control.

The parameter is enabled if P1.13 (tuning mode selection) is 10 (auto tuning), 11 (semi-auto tuning) or 15(Shorter cycle time operation mode).

Adjust P1.15 (Auto tuning gain 1) before adjusting this parameter.

With this parameter, the positioning and settling time of auto tuning and semi-auto tuning is reduced, so that the cycle time is effectively reduced. While a larger value reduces the positioning and settling time, an overshoot is likely to be caused.

P1.51 (moving average S-curve time) and P1.54 (position command response time constant) are automatically adjusted in relation to the reference value of this parameter.

What is positioning and settling time
 Time from completion of issuance of command frequency to issuance of in-position signal.
 The time varies according to various conditions such as the frequency matching the traveling distance, acceleration/deceleration rate, and stopping accuracy.
 Adjustment of the entire system including the host and servo to optimum conditions is necessary to reduce the positioning and settling time.

Tips

P1.20	Easy tuning:stroke setting	Default value	2.00
	Setting range	0.01~200.00 [rev]	
P1.21	Easy tuning:speed setting	Default value	500.00
	Setting range	10.00 to max. rotation speed [r/min]	
P1.22	Easy tuning:timer setting	Default value	1.500
	Setting range	0.000~5.000 [s]	
P1.23	Easy tuning:direction selection	Default value	0
	Setting range	0: Forward⇔reverse rotation 1: Forward rotation only 2: Reverse rotation only	

Enter the parameter to perform easy tuning.

P1.25	Max. rotation speed (for position and speed control)	Default value	3000.00
P1.26	Max. rotation speed (for torque control)	Default value	3000.00
	Setting range	Specify according to the motor model	

Enter the maximum rotation speed of the servo motor for position, speed and torque control.

However, this parameter is disabled at pulse operation.

There is a difference of about 100r/min between the reference value and actual servo motor rotation speed under torque control.

Use P1.96 (speed limit gain for torque control) to adjust the error.

P1.27	Forward rotation torque limit	Default value	300
P1.28	Reverse rotation torque limit	Default value	300
	Setting range	0~300%	

 Enter the limit to be set on the output torque of the servo motor.

If the input signal (EI signal: torque limit 0, 1, etc.) is turned off, this limit is enabled.

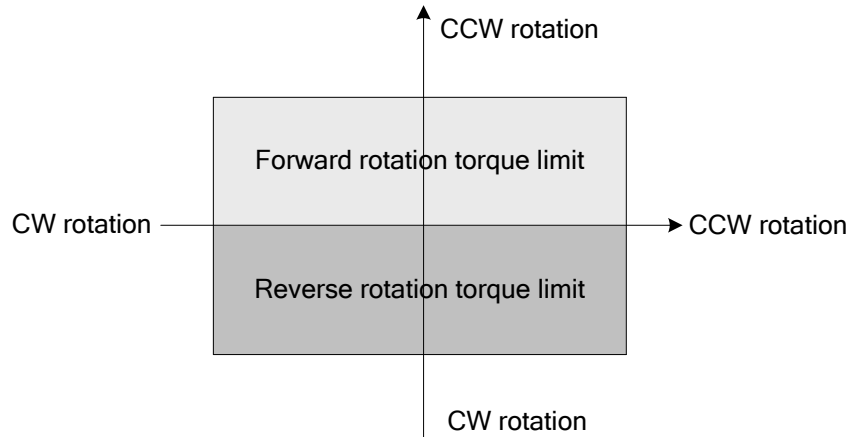

P1.29	Speed coincidence range	Default value	50
	Setting range	10 to max. rotation speed [r/min]	

 Enter the range in which the "speed coincidence" output signal (EOUT signal) is turned on.

The speed coincidence signal is turned on if the actual servo motor rotation speed is nearly the command speed.

In case of a default value of 50r/min, the speed coincidence signal is turned on in the range of ± 50 r/min to the command speed.

If the command speed is not reached due to P1.25 (maximum rotation speed), override or similar, the signal is turned off.

The speed coincidence signal does not turn on if the [FWD] or [REV] signal is turned off.

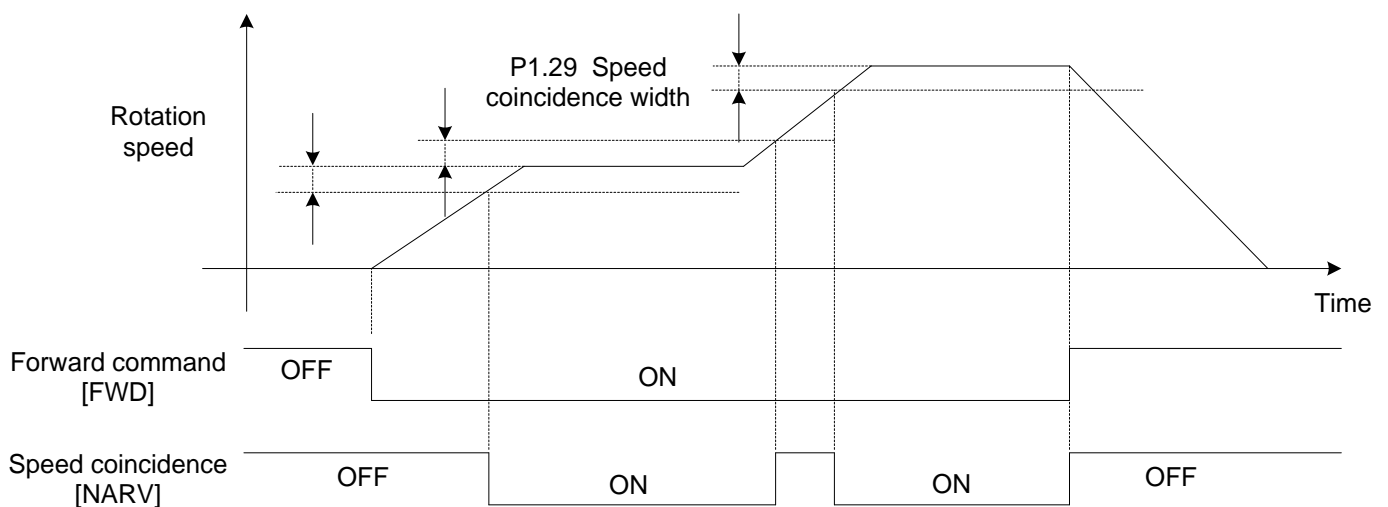

- For the speed coincidence signal, refer to "Speed coincidence [NARV]".

P1.30	Zero speed range	Default value	50
	Setting range	10 to max. rotation speed [r/min]	

 The EOUTn signal is turned ON at servomotor rotation speeds within the reference value.

P1.31	Deviation unit selection	Default value	0
	Setting range	0: Unit 1: Pulse	

 Enter the unit of position deviation.

Select 0 (unit) for the unit after multiplication by the electronic gear ratio. Unit is displayed.

Select 1 (pulse) for the unit before multiplication by the electronic gear ratio. (Unit of encoder pulse amount).

This setting is related to the unit of all position deviation monitored with the keypad, DA Loader or analog output 1/2 signal.

P1.32	Zero deviation range/In-position range	Default value	100
	Setting range	0~200000 [pulse] / [units]	

• Zero deviation range

Enter the activation level of the "zero deviation" output signal(EOUT signal).

The signal is turned on at position deviation within the reference value.

• In-position range

Enter the deviation condition of the "in-position (INP)" output signal(EOUT signal).

The in-position (INP) signal is turned on if position deviation is within this reference value and the motor rotation speed is within the reference value of the "zero speed range."

However, the condition includes completion of pulse elimination from the inside of the servo motor drive for motion by positioning, homing and manual position control.

• The setting unit is the one specified with P1.31 (deviation unit selection).

*P1.33	In-position output format	Default value	0
	Setting range	0: Level 1: Single shot	
P1.34	In-position minimum OFF time/Single shot ON time	Default value	20
	Setting range	1~1000 [ms]	
P1.35	In-position judgment time	Default value	0
	Setting range	0~1000 [ms]	

 Enter the output format, minimum OFF time / Single shot ON time and judgment time of the in-position [INP] signal.

In-position output format: Select the format of the output signal (refer to the timing chart shown below).

In-position minimum OFF time / Single shot ON time: For the single shot output format, enter the time for which the output signal is turned on.

In-position judgment time: Enter the judgment time needed to recognize in-position.

In-position signal

The in-position signal is turned on if position deviation is within the reference value of "zero deviation range" and the motor rotation speed is within the reference value of "zero speed range"(AND condition of zero speed and zero deviation).

The output timing of this signal substantially varies according to the setting of P1.31 (deviation unit selection).

Check the reference value again to use. Refer to the following timing chart.

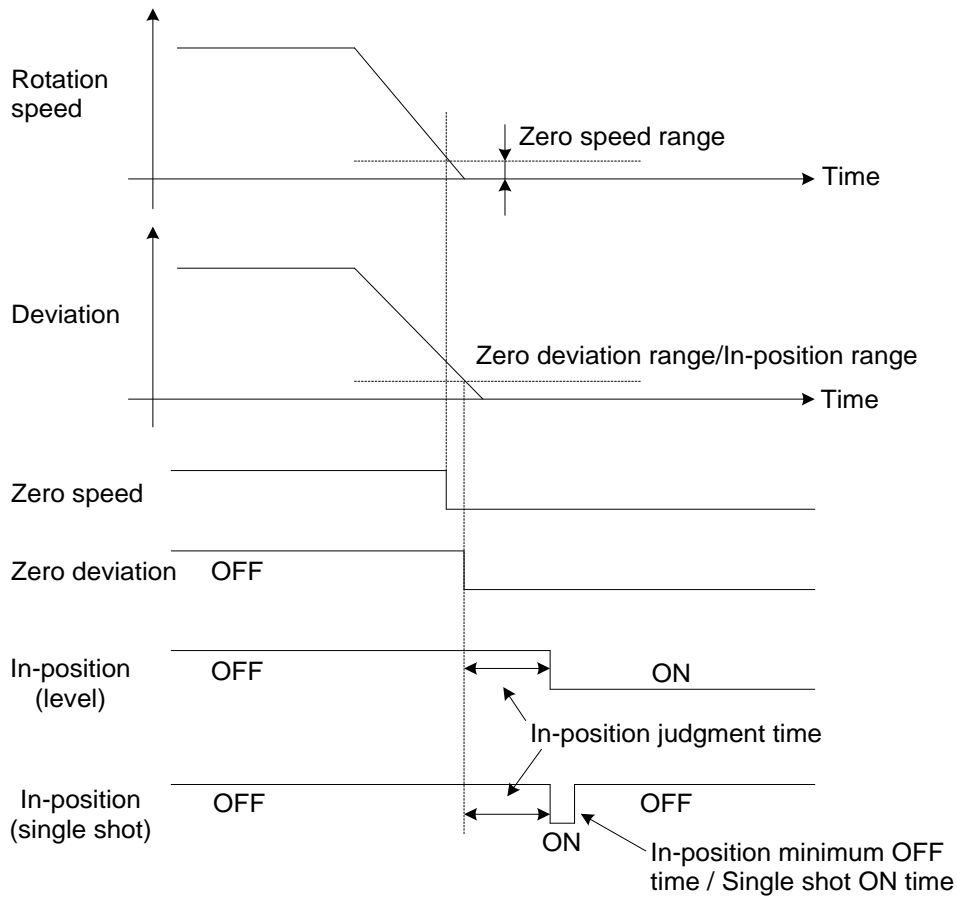

P1.36	Acceleration/deceleration selection at speed control		Default value	0
	Setting range	0: Disable 1: Enable		
P1.37	Acceleration time 1		Default value	100.0
P1.38	Deceleration time 1		Default value	100.0
P1.39	Acceleration time 2		Default value	500.0
P1.40	Deceleration time 2		Default value	500.0
	Setting range	0.0~99999.9 [ms]		

The parameter is enabled for acceleration and deceleration motions under speed control and position control (automatic operation, homing and manual position control operation).

These parameters are disabled during pulse operation.

The acceleration/deceleration time setting indicates the time from 0 (zero) to 2000r/min.

Acceleration time 2 and deceleration time 2 are enabled while the "ACC0" selection signal remains turned on.

ACC0 can be turned on or off at any time and the acceleration time and deceleration time are similarly changed.

ACC0 is assigned to an input signal (EI signal). Selection follows the table below.

ACC0(14)	Acceleration time	Deceleration time
OFF	P1.37	P1.38
ON	P1.39	P1.40

Use P1.36 (acceleration / deceleration selection at speed control) to select acceleration/deceleration of speed control.

To perform position control at the host control unit and to perform speed control at the servo system, enter "0" to P1.36 (control method to output analog speed command voltage at host control unit).

To perform speed control independently in the servo system, enter "1" to P1.36 to enable P1.37 through P1.40. To perform position control independently in the servo system, P1.37 through P1.40 are enabled regardless of the setting of P1.36.

The acceleration and deceleration of speed limit under torque control is in accord with the parameter P1.36.

Acceleration and deceleration occurs according to the table shown above if P1.36 is set at "1" (enable).

If the acceleration/deceleration time data is "0" during operation with position data, the values specified in these parameters are enabled.

Timing chart

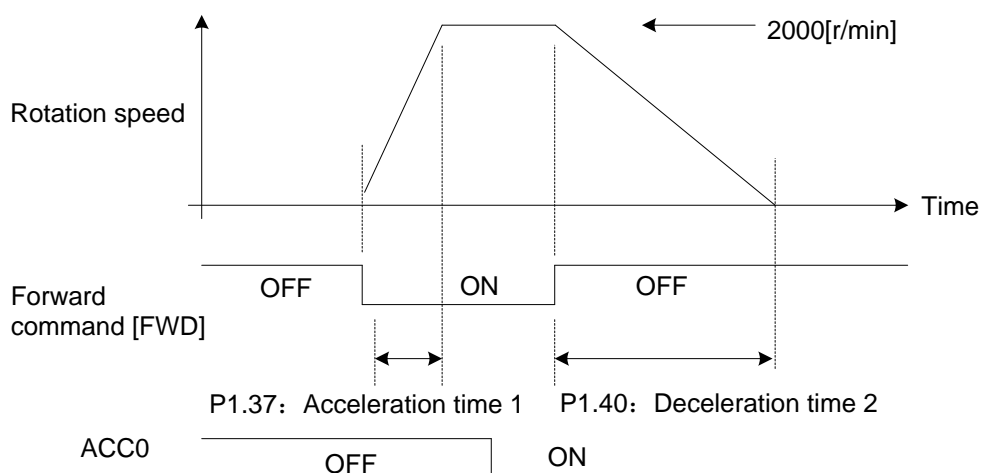

P1.41	Manual feed speed 1 for position and speed control/speed limit 1 for torque control	Default value	100.00
P1.42	Manual feed speed 2 for position and speed control/speed limit 2 for torque control	Default value	500.00
P1.43	Manual feed speed 3 for position and speed control/ speed limit 3 for torque control	Default value	1000.00
P1.44	Manual feed speed 4 for position and speed control/speed limit 4 for torque control	Default value	100.00
P1.45	Manual feed speed 5 for position and speed control/speed limit 5 for torque control	Default value	100.00
P1.46	Manual feed speed 6 for position and speed control/speed limit 6 for torque control	Default value	100.00
P1.47	Manual feed speed 7 for position and speed control/speed limit 7 for torque control	Default value	100.00
	Setting range	0.01 to max. rotation speed [r/min]	

 Enter the speed of manual feed for speed control and position control.

For torque control, if P2.56 (speed limit selection at torque control) is "0," the reference value of P1.26 (maximum rotation speed) becomes the speed limit.

If P2.56 (speed limit selection at torque control) is "1," the speed limit is enabled as shown in the table below.

Combine input signals (EI signal: multi-step speed selection 1 [X1] to 3 [X3]) to select.

Multi-step speed selection			Enabled parameter	
X3	X2	X1	Under speed/ control	Under torque control
OFF	OFF	OFF	VREF terminal voltage (analog speed command)	VREF terminal voltage (analog speed limit)
OFF	OFF	ON	41: Manual feed speed 1	41: Speed limit 1 for torque control
OFF	ON	OFF	42: Manual feed speed 2	42: Speed limit 2 for torque control
OFF	ON	ON	43: Manual feed speed 3	43: Speed limit 3 for torque control
ON	OFF	OFF	44: Manual feed speed 4	44: Speed limit 4 for torque control
ON	OFF	ON	45: Manual feed speed 5	45: Speed limit 5 for torque control
ON	ON	OFF	46: Manual feed speed 6	46: Speed limit 6 for torque control
ON	ON	ON	47: Manual feed speed 7	47: Speed limit 7 for torque control

6.2 Control Gain and Filter Setting Parameters (P1.51~99)

◆ The parameters with “***” indicate that they are enabled only when power on again after parameter setting.

P1.51	Moving average S-curve time	Default value	***
	Setting range	0、 2~500 (× 0.125 [ms])	
P1.52	Low-pass filter (for S-curve) time constant	Default value	0.0
	Setting range	0.0~1000.0 [ms]	
P1.53	Command pulse smoothing function	Default value	0
	Setting range	0: Disable 1: Enable	

 Filters can be added to commands for smoother follow-up.

Moving average S-curve time	<p>This parameter is enabled under position control.</p> <p>Specify the moving average S-curve filter time to position commands.</p> <p>A larger setting at low command pulse frequencies or large electronic gear ratios can reduce the torque ripple caused by fluctuation of the command pulse.</p> <p>The new setting of this parameter is reflected when both the position command and filter accumulation pulse are "0".</p> <p>If P1.13 (tuning mode selection) is 10 (auto tuning), 11 (semi-auto tuning) or 15(shorter cycle time operation mode) automatic adjustment is made inside the servo motor drive.</p>
Low-pass filter (for S-curve) time constant	<p>Enter the low-pass filter (for S-curve) filter time constant in relation to position commands and speed commands.</p> <p>Acceleration and deceleration are made so that an approximate S-curve is drawn.</p>
Command pulse smoothing function	<p>The parameter is enabled under position control.</p> <p>If the function is enabled, smoothing is added to the position command every 2 ms intervals.</p> <p>A larger setting at low command pulse frequencies or large electronic gear ratios can reduce the torque ripple caused by fluctuation of the command pulse.</p> <p>While the setting can be changed at any time, the new setting is reflected when both the position command and filter accumulation pulse are "0".</p>

Function configuration block

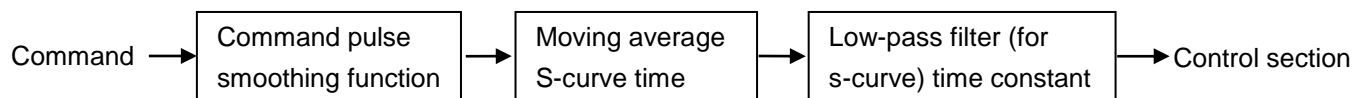

P1.54	Position command response time constant	Default value	***
	Setting range	0.00~250.00 [ms]	

 Specify the following response characteristics to commands. A smaller setting improves the response characteristics.

Automatic adjustment is made inside the amplifier if P1.13 (tuning mode selection) is 10 (auto-tuning), 11 (semi-auto tuning) or 15(shorter cycle time operation mode).

P1.55	Position loop gain 1	Default value	***
	Setting range	1~2000 [rad/s]	
P1.56	Speed loop gain 1	Default value	***
	Setting range	1~2000 [Hz]	
P1.57	Speed loop integration time constant 1	Default value	***
	Setting range	0.5~1000.0 [ms]	

 Position loop gain 1: Position disturbance response setting. A larger setting improves the response characteristics.

Speed loop gain 1: Speed disturbance setting. A larger setting improves the response characteristics.

Speed loop integration time constant 1: Integration time constant setting of speed response. A smaller setting improves the response.

Too much a response characteristic may cause vibration or noise.

Automatic adjustment is made inside the amplifier if P1.13 (tuning mode selection) is other than 12 (manual tuning).

P1.58	Feed forward gain 1	Default value	0.000
	Setting range	0.000~1.500	

 A larger setting decreases the position deviation amount, improving the response characteristics.

Set at 1.000 to reduce the position deviation at a constant speed to almost zero (except during acceleration or deceleration).

Use this parameter to increase the synchronization accuracy between two axes of synchronous control or similar.

For regular point-to-point operation, set the parameter at 0.500 or less (approximate value).

P1.59	Torque filter time constant for position and speed control	Default value	***
P1.60	Torque filter time constant for torque control	Default value	0.00
	Setting range	0.00~20.00 [ms]	

Torque filter time constant for position and speed control	<p>This parameter is enabled under speed and position control.</p> <p>Add a filter to internal torque commands.</p> <p>The response of the servo system is improved and resonance is suppressed.</p> <p>In particular, the reference value should be larger with large load inertia.</p> <p>Automatic adjustment is made inside the amplifier in other than the manual tuning mode.</p> <p>Set P1.94 at 0 to allow manual settings.</p>
Torque filter time constant for torque control	<p>The parameter is enabled under torque control. Add a filter to external torque commands. Good effects can be expected for a system prone to electric noise or one with fluctuation in the command voltage.</p>

P1.61	Gain switch cause	Default value	1
	Setting range	0: Position deviation (x10) 1: Feedback speed 2: Command speed 3: External switch (EI signal switch)	
P1.62	Gain switch level	Default value	50
	Setting range	P1.61 = 0: 1~1000 [pulse] P1.61 = 1, 2: 1~1000 [r/min]	
P1.63	Gain switch time constant	Default value	1
	Setting range	0~100 [ms]	
P1.64	Position loop gain 2	Default value	100
	Setting range	30~200 [%]	
P1.65	Speed loop gain 2	Default value	100
	Setting range	30~200 [%]	
P1.66	Speed loop integration time constant 2	Default value	100
	Setting range	30~200 [%]	
P1.67	Feed forward gain 2	Default value	100
	Setting range	30~200 [%]	

 The gain of the servo system is switched from the first gain (P1.55 to 58) to the second gain (P1.64 to 67).

Noise and vibration during stoppage can be reduced through gain switching.

Select the gain switch cause with P1.61.

The unit of the reference value of the second gain (P1.64 to 67) is "%." Specify the ratio to the first gain.

[Example] If P1.56 (speed loop gain 1) is 100 Hz and P1.65 (speed loop gain 2) is 80%, the second gain is 80 Hz.

P1.64 (position loop gain 2) is similar. If P1.57 (speed loop integration time constant 1) is 20 ms and P1.66 (speed loop integration time constant 2) is 50%, integration time constant 2 is 40 ms.

The timing chart of each signal is shown below.

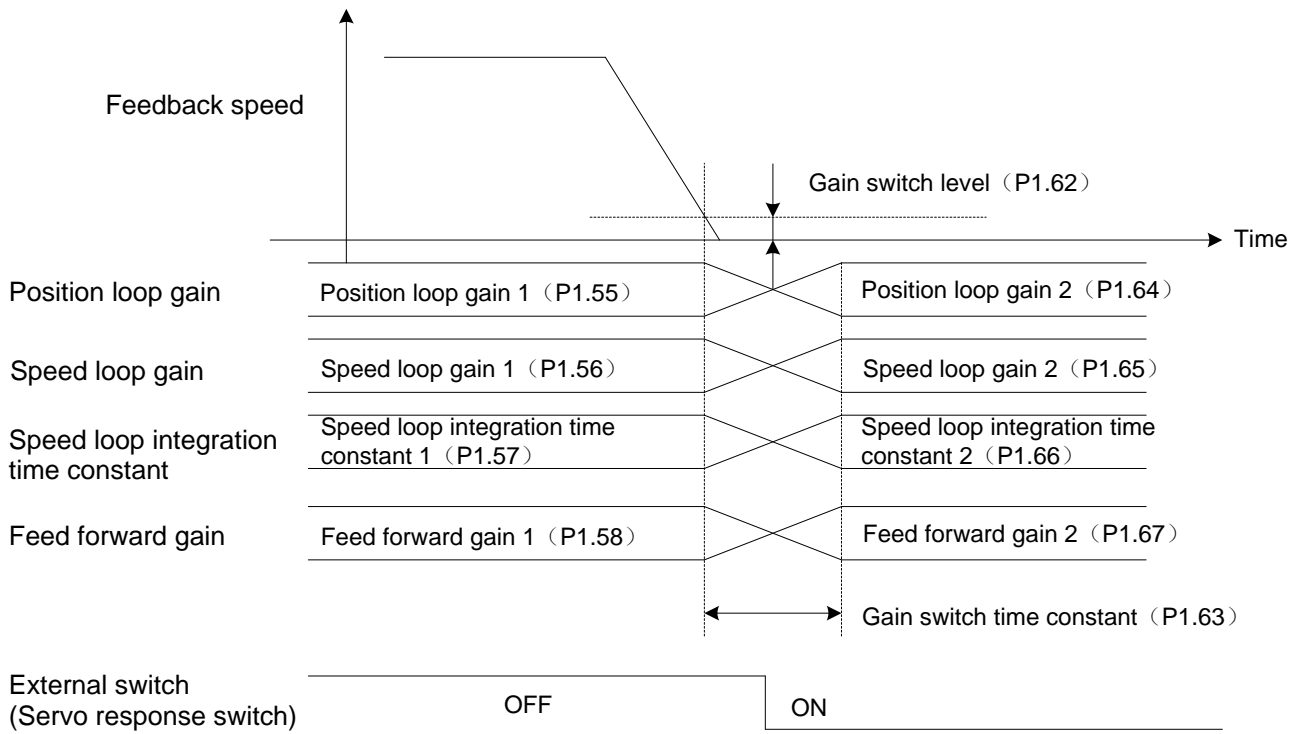

If external switch is selected as a gain switch cause, changeover to the second gain occurs during OFF-to-ON transition as shown above.

In this case, you can turn on or off at an arbitrary timing without relations to the motor motion.

The gain of the go stroke and that of the return stroke of a reciprocal motion can be switched.

P1.68	Acceleration compensation gain	Default value	0
	Setting range	0~200 [%]	

- Enter the following characteristics to the command.
- A larger reference value reduces the position deviation caused during acceleration or deceleration while improving following characteristic to position commands.
- Too large reference value may cause vibration or noise.

P1.70	Automatic notch filter selection	Default value	1
	Setting range	0: Disable 1: Enable 2: Enable (notch filter 1 only)	
P1.71	Notch filter 1, frequency	Default value	4000
	Setting range	10~4000 [Hz]	
P1.72	Notch filter 1, attenuation	Default value	0
	Setting range	0~40 [dB]	
P1.73	Notch filter 1, width	Default value	2
	Setting range	0~3	
P1.74	Notch filter 2, frequency	Default value	4000
	Setting range	10~4000 [Hz]	

P1.75	Notch filter 2, attenuation		Default value	0
	Setting range	0~40 [dB]		
P1.76	Notch filter 2, width		Default value	2
	Setting range	0~3		

 Specify to suppress resonance of the mechanical system. Up to two resonance points can be suppressed. Select 1 (enable) for automatic notch filter selection to adjust the notch filter automatically to the best value and suppress resonance.

Parameters automatically adjusted in this case include P1.71 to 76. Values are stored in the EEPROM every 10 minutes.

• How to set the notch filter

(1) If there is resonance in the mechanical system, a notch filter is automatically set.

If resonance is not suppressed, set P1.70 (automatic notch filter selection) at 0 (disable) and follow the procedure below to manually adjust the notch filter.

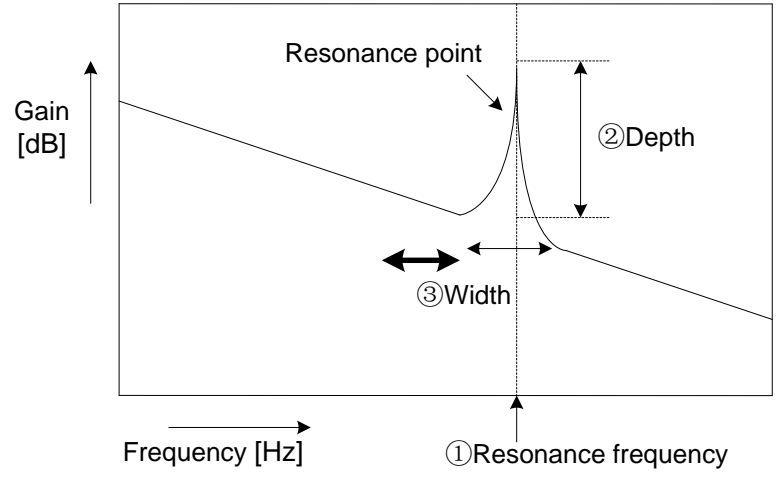

(2) Enter the resonance frequency of and attenuation of the resonance point of the machine into parameters.

- ① Resonance frequency: P1.71 (Notch filter 1 frequency)
- ② Depth: P1.72 (Notch filter 1 attenuation)※
- ③ Width: P1.73 (Notch filter 1 width)

※ Too much attenuation may undermine stability of the control. Do not enter too much setting. (Set at 0dB to disable the notch filter.)

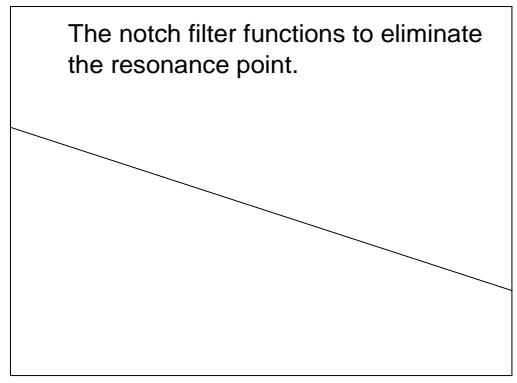
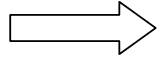
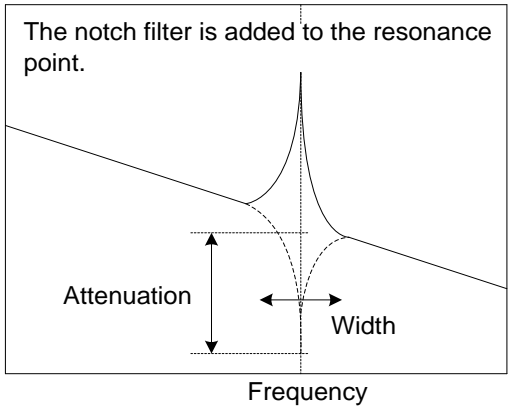

(3) Approximate reference value

Refer to the table below for the approximate reference value.

Frequency [Hz]	200	500	700	1000
Attenuation [dB]	-5	-10	-15	-20
Width	2,3			

- Setting the notch filter

Relation between automatic notch filter and manual notch filter

P1.70(Automatic notch filter selection)	Notch filter 1	Notch filter 2
0	Manual	Manual
1	Auto	Auto
2	Auto	Manual

Notch filter setting at parameter change

P1.70(Automatic notch filter selection)	Notch filter setting value	
	Notch filter 1	Notch filter 2
0 → 1	Cleared	Cleared
1 → 0	Remained	Remained
0 → 2	Cleared	Remained
1 → 2	Cleared	Remained
2 → 0	Remained	Remained
2 → 1	Cleared	Cleared

P1.77	Auto vibration suppressing control selection	Default value	0
	Setting range	0: Disable 1: Enable 2: Communications setting	
P1.78	Vibration suppressing anti resonance frequency 0	Default value	300.0
	Setting range	1.0~300.0 [Hz]	
P1.79	Vibration suppressing workpiece inertia ratio (vibration suppressing resonance frequency) 0	Default value	0
	Setting range	0~80 [%]	
P1.80	Vibration suppressing anti resonance frequency 1	Default value	300.0
	Setting range	1.0~300.0 [Hz]	
P1.81	Vibration suppressing workpiece inertia ratio (vibration suppressing resonance frequency) 1	Default value	0
	Setting range	0~80 [%]	

P1.82	Vibration suppressing anti resonance frequency 2	Default value	300.0
	Setting range	1.0~300.0 [Hz]	
P1.83	Vibration suppressing workpiece inertia ratio (vibration suppressing resonance frequency) 2	Default value	0
	Setting range	0~80 [%]	
P1.84	Vibration suppressing anti resonance frequency 3	Default value	300.0
	Setting range	1.0~300.0 [Hz]	
P1.85	Vibration suppressing workpiece inertia ratio (vibration suppressing resonance frequency) 3	Default value	0
	Setting range	0~80 [%]	
P1.86	Vibration suppressing damping coefficient	Default value	0.0000
	Setting range	0.0000~0.1000	

 These parameters are enabled only under position control.

Use these parameters to specify the anti resonance frequency to suppress workpiece vibration (vibration control).

Set at 300.0 Hz (Default value) to disable vibration suppressing control function.

Set P1.77 (automatic vibration suppressing control selection) at 1 (enable) to repeat starting and stopping the motor multiple times while automatically detecting the anti resonance frequency of the machine and adjusting P1.78 (vibration suppressing anti resonance frequency 0) to the best value.

To use this function, always reserve 1.5s or longer stopping time.

Use vibration suppressing workpiece inertia ratio (vibration suppressing resonance frequency) 0 to enter the ratio of a vibrating inertial body such as the arm to the inertia of the entire system.

The enabled parameter is selected through the EI input signal as shown in the following table.

The RS-485 communications setting is enabled if the parameter P1.77 (automatic vibration suppressing control selection) is set at 2 (communications setting).

Anti resonance frequency 1	Anti resonance frequency 0	Enabled vibration suppressing anti resonance frequency	Enabled vibration suppressing workpiece inertia ratio
OFF	OFF	P1.78	P1.79
OFF	ON	P1.80	P1.81
ON	OFF	P1.82	P1.83
ON	ON	P1.84	P1.85

P1.87	Model torque filter time constant	Default value	***
	Setting range	0.00~20.00 [ms]	

 Specify the feed forward control filter time constant of the torque for a model of inertia moment.

Automatic adjustment is made inside the servo motor drive in other than the manual tuning mode.

This function is not used when P1.13 (tuning mode selection) is set to "14" (trace operation mode).

P1.88	Position loop integration time constant	Default value	***
	Setting range	1.0~1000.0 [ms]	
P1.89	Position loop integration limiter	Default value	0
	Setting range	0 to Max. rotation speed [r/min]	

 Use to improve interpolation accuracy of axes when interpolating two or more servo motor axes of an X-Y table or similar.

P1.88 (position loop integration time constant) is automatically adjusted inside the amplifier in other than the manual tuning mode.

The position loop integration time constant is disabled if P1.89 (position loop integration limiter) is 0.

To enter manually, enter settings so that the following equation is satisfied: Position loop integration time constant \geq Speed loop integration time constant x 5.

P1.90	Load torque observer	Default value	0
	Setting range	0: Disable 1: Enable	

 Set at 1 (enable) to suppress effects of load disturbance torque and improve speed fluctuation.

Use the parameter to reduce the positioning settling time due to effects of the load torque such as friction.

P1.91	P/PI auto switch selection	Default value	0
	Setting range	0: Disable 1: Enable	

 The speed adjuster switches to P (proportional) or PI (proportional + integral) control.

Set at 1 (enable) to automatically switch according to the setting of P1.61 (Gain switch cause).

The switching level follows the reference value of P1.62 (gain switch level).

The state at switching is shown below.

P1.61(Gain switch cause)	Condition	State
Position deviation, feedback speed, Command frequency, command speed	Reference value level or over	P Control
	Reference value level or less	PI Control
External signal switch (EI signal switch)	ON	P Control
	OFF	PI Control

To apply the brake from an external unit, arrange the P control state.

P1.92	Speed range for friction compensation	Default value	10.0
	Setting range	0.1~20.0 [r/min]	
P1.93	Coulomb friction torque for friction compensation	Default value	0
	Setting range	0~50 [%]	

 Specify in a system with reversing speeds if smooth reversing motions are not obtained due to friction.

Specify the speed at which static friction changes to dynamic friction, in these parameters.

Set P1.92 (speed range for friction compensation) at about 1.0 to 10.0 r/min.

Set P1.93 (Coulomb friction torque for friction compensation) at the torque equivalent to dynamic friction (Coulomb friction).

Friction compensation is disabled if the friction compensation torque reference value is 0.

P1.94	Torque filter setting mode		Default value	1
	Setting range	Setting value	P1.59	P1.87
		0	Do not set automatically	Set automatically.
		1	Set automatically.	Set automatically.
		2	Do not set automatically	Do not set automatically
		3	Set automatically.	Do not set automatically

 This parameter is enabled under position and speed control.

Select either to set P1.59 (torque filter time constant) and P1.87 (model torque filter time constant) automatically or not in other than the manual tuning mode.

Select “do not set automatically” to manually specify P1.59 (torque filter time constant) and P1.87 (model torque filter time constant) regardless of the setting of P1.13 (tuning mode selection).

When “1(set automatically)” is selected, the parameter is automatically adjusted in the servo motor drive in other than the manual tuning mode.

The setting of P1.87 (model torque filter time constant) becomes disabled when P1.13 (tuning mode selection) is set to “14” (trace operation motion).

P1.95	Model torque calculation and speed observer selection		Default value	3
	Setting range	Setting	Model torque calculation	Speed observer
		0	Disable	Disable
		1	Enable	Disable
		2	Disable	Enable
		3	Enable	Enable

 This parameter is enabled under position and speed control.

Select whether model torque calculation and speed observer are enabled or disabled.

If model torque calculation is disabled, the torque feed forward calculation using a model of moment of inertia of load is disabled.

Use the parameter to perform position and speed control at the host controller.

Select "enable" for speed observer during regular operation. Speed compensation is made and stability is improved.

Parameters related to response of the control system are automatically adjusted according to the setting of auto tuning 1 or 2. However, the function of P1.54 (position command response time constant) is canceled internally.

P1.96	Speed limit gain for torque control		Default value	4.0
	Setting range	0.0~50.0		

 This parameter is enabled under torque control.

If the rotation speed exceeds the reference value of P1.26 (maximum rotation speed (for torque control)) under torque control, the command torque is reduced so that the rotation speed becomes near the reference value. At this time, an error is caused in the rotation speed in relation to the reference value. Take into consideration that the parameter adjusts the error. While a larger reference value decreases the error, excessive value will cause instability.

6.3 Automatic Operation Setting Parameters (P2.01~50)

◆The parameters with “*” indicate that they are enabled only when power on again after parameter setting.

P2.01	Decimal point position of positioning data	Default value	0
	Setting range	0: 0 1: 0.1 2: 0.01 3: 0.001 4: 0.0001 5: 0.00001	

Specify the decimal point position of the displayed position data.

P2.06	Homing speed	Default value	500.00
	Setting range	0.01 to Max. rotation speed [r/min]	

Specifies the homing speed.

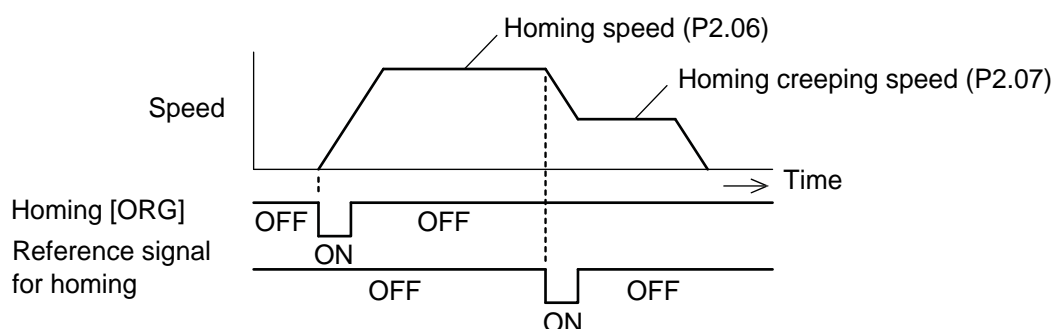

P2.07	Homing creeping speed	Default value	50.00
	Setting range	0.01 to Max. rotation speed [r/min]	

Specify the motion speed taken after the reference signal for homing (deceleration starting signal) is detected.

*P2.08	Starting direction for homing	Default value	0
	Setting range	0: Forward rotation 1: Reverse rotation 2: Condition judgment start	

Specify the starting direction of the homing motion.

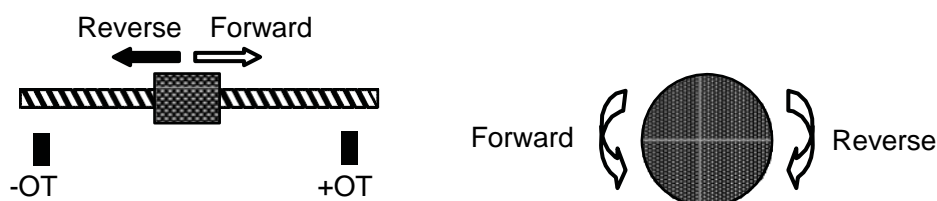

- For the direction of 2: condition judgment start.
Forward direction: direction of position increase.
Reverse direction: direction of position decrease.
The forward/reverse direction depends on parameter P1.04 (rotation direction selection).

P2.09	Reverse traveling unit amount for homing	Default value	0
	Setting range	0 to 2000000000 [units]	

Not a compulsory item

Specify the reverse traveling amount taken in the direction opposite to the starting direction for homing at the start of homing motion.

If a reference signal for homing (deceleration starting signal) or reference signal for shift operation is detected during reverse travel, movement toward the homing direction after reference signal detection begins.

Use the setting to reduce the homing time.

Use if the stopping position is in the direction opposite to the starting direction for homing and the maximum distance from the stopping position to the zero position is always known.

The unit amount depends on P1.06 (numerator 0 of electronic gear) and P1.07 (denominator of electronic gear).

If neither the reference signal for homing nor reference signal for shift operation is detected during reverse motion, movement in the starting direction for homing begins after reverse motion by the preset traveling amount.

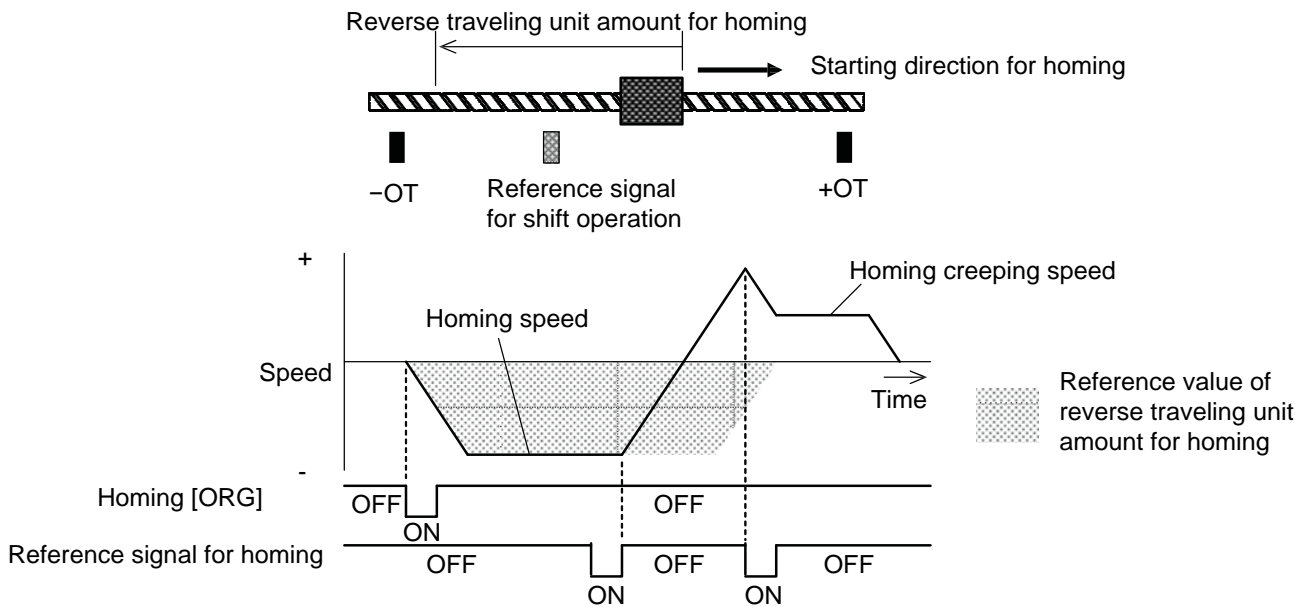

*P2.10	Homing direction	Default value	0
	Setting range	0: Forward rotation direction 1: Reverse rotation direction	

Specify the direction of the zero position when viewed from the reference signal for shift operation. The reference signal for shift operation is passed during home position shift unit amount travel in this direction.

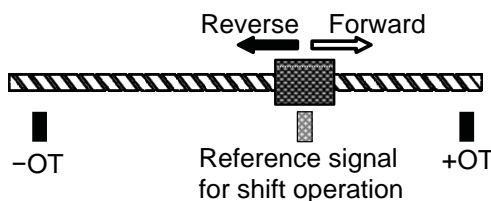

• If +OT or -OT is set as a reference signal for homing (deceleration starting signal), this parameter is disabled and the direction opposite to the one toward the specified OT signal is the homing direction.

The definition of the direction of motion is shown below.

Forward: direction of position increase

Reverse: direction of position decrease

*P2.11	Reference signal for shift operation	Default value	1
	Setting range	0: Home position LS 1: Encoder Z-phase 2: +OT 3: -OT 4: Interrupt input 5: Stopper	

Specify the signal serving as a standard of the home position.

Specify the signal serving as a standard of the home position.

The position of a travel from the specified reference signal toward the homing direction after reference signal detection by the home position shift unit amount is the home position.

The home position accuracy (reproducibility of zero position) is the highest with 1 (encoder Z-phase).

If the Z-phase is selected, the reference signal for shift operation can be installed.

Except the encoder Z-phase, 4 (interrupt input) has higher home position accuracy than other signal (reproducibility of zero position).

This is because 4 (interrupt input) detects the interrupt position with a signal while 0 (home position LS), 2 (+OT) and 3 (-OT) detects a level.

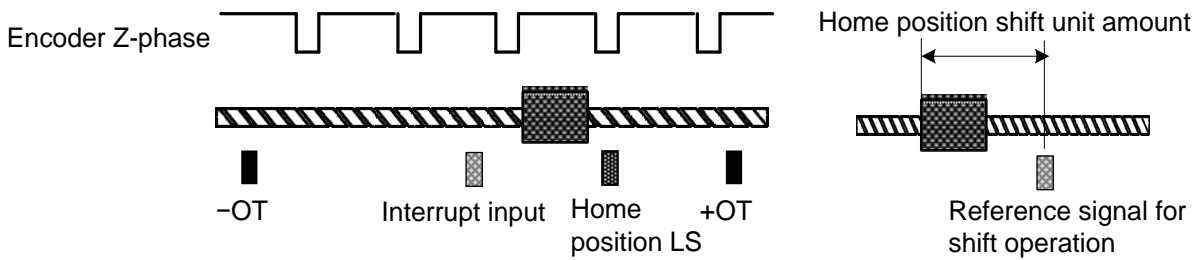

- If one among 0 (home position LS), 2 (+OT) and 3 (-OT) is selected, there is an error of ± 250 pulses in the zero position at a creep speed for homing of 50 r/min.

*P2.12	Reference signal for homing	Default value	0
	Setting range	0: Home position LS 1: +OT 2: -OT	

If the encoder Z-phase is selected as a reference signal for shift operation, specify the timing signal for deceleration to the creep speed for homing. The first encoder Z-phase after reference signal for shift operation detection is the starting point of the home position shift unit amount.

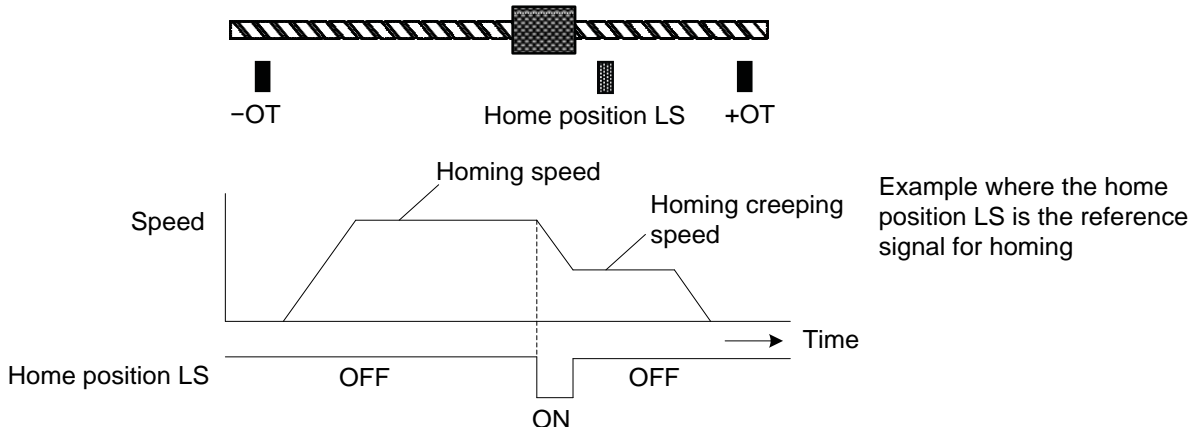

*P2.13	Home position LS signal edge selection	Default value	0
	Setting range	0: ON Rising edge 1: OFF Rising edge	

Not a compulsory item

Specify the enabling timing of the home position LS signal if the home position LS is specified as a reference signal for shift operation reference signal for homing.

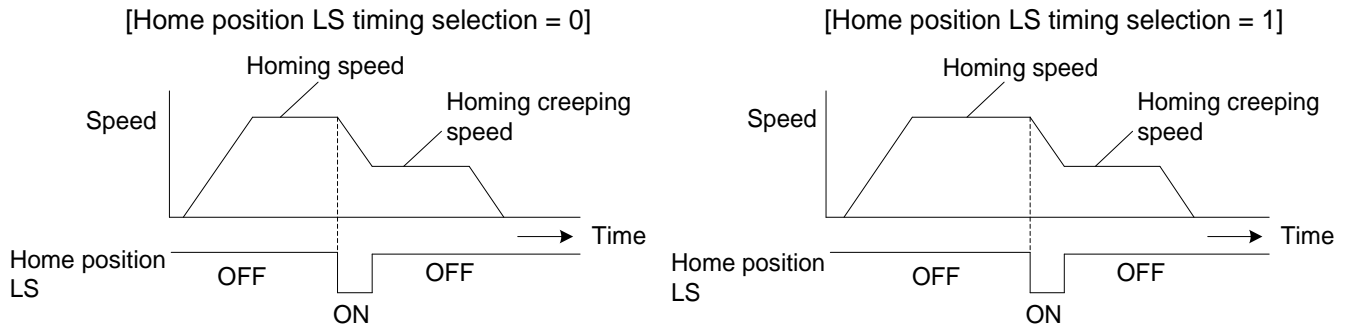

P2.14	Home position shift unit amount	Default value	1000
	Setting range	0 to 2000000000 [units]	

Specify the distance (traveling amount) from the reference signal for shift operation to the home position.

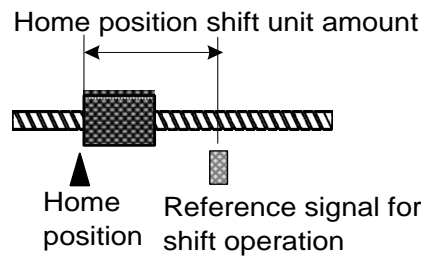

*P2.15	Deceleration operation for creep speed	Default value	0
	Setting range	0: Reverse rotation is disabled	1: Reverse rotation is enabled

Not a compulsory item

Specify 1 (reverse rotation is enabled) to return upon detection of the reference signal for shift operation during movement at the homing speed in the homing direction after reference signal detection temporarily to the point ahead of the reference signal for shift operation and move at the creep speed for homing again in the homing direction after reference signal detection to the position (home position) the home position shift unit amount away from the reference signal for shift operation.

Accurate homing can be executed only with the reference signal for shift operation without a reference signal for homing.

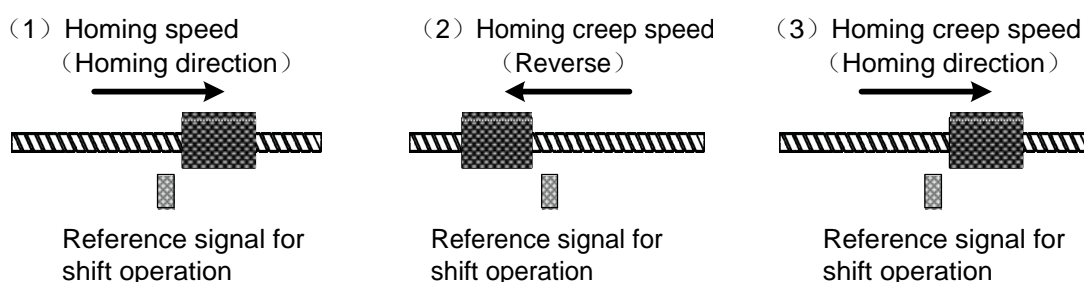

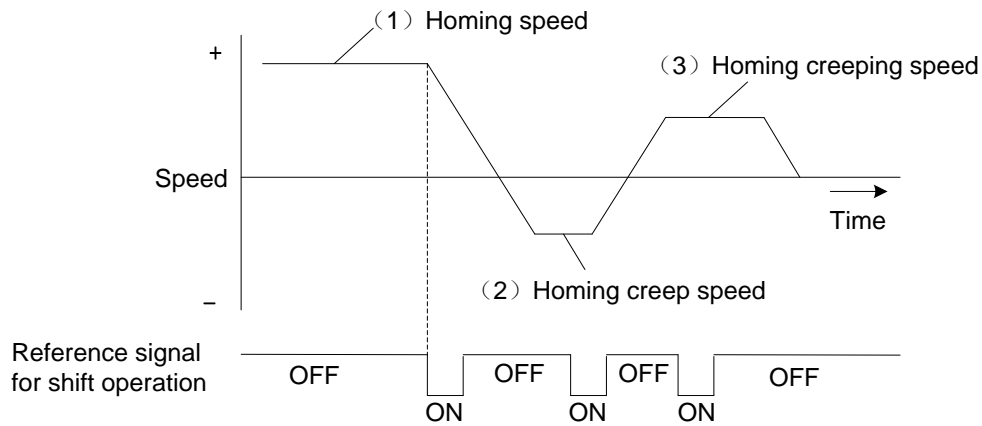

P2.16	Home position after homing completion	Default value	0
	Setting range	-2000000000 to 2000000000 [units]	

Not a compulsory item

Specify the coordinate position of the homing completion point.

After a homing is normally finished, the current position is replaced with the reference value of this parameter.

Specify if the homing motion completion point is other than zero.

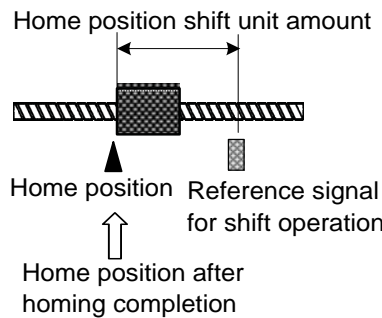

P2.17	Home position detection range	Default value	0
	Setting range	0: Always ON after homing completion	1 to 2000000000 [units]

Not a compulsory item

Specify the range in which the homing completion signal is turned on.

If the current position is between the positive home position detection range and negative home position detection range around the home position, homing completion is turned on.

Specify 0 to always turn the homing completion signal on after a homing is finished.

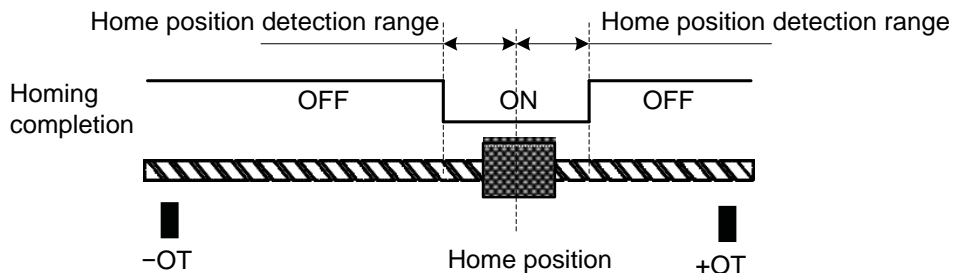

The zero position is not necessarily 0. The home position is the position specified as a home position after homing completion (P2.16) or preset position (P2.19).

P2.18	Deceleration time at OT during homing	Default value	100.00
	Setting range	0.0 to 99999.9 [ms]	

 Specify the deceleration time taken after +OT or -OT is detected during homing motion.

Specify the time taken to decelerate from 2000 to 0 r/min. Determine the setting under consideration of the homing speed and moving range after the OT sensor. ("0.7" in the equation indicates the safety factor.)

[Example of calculation of reference value]

$$\begin{aligned}
 \text{Moving range after OT} \times 0.7 &= \text{Homing speed} \times \text{Reduction ratio} \times \text{Ball screw lead} \\
 &\quad \times (\text{Homing speed}/2000 \text{ r/min} \times \text{Deceleration time after homing OT}/1000/60) \\
 &\quad \times 1/2 \\
 30 \text{ mm} \times 0.7 &= 1000.00 \text{ r/min} \times (1/5) \times 20 \text{ mm} \times (1000.00 / 2000 \text{ r/min} \\
 &\quad \times \text{Deceleration time at OT during homing} / 1000/60) \times 1/2
 \end{aligned}$$

Deceleration time at OT during homing = 1260.0 ms

- If 1 (stop) is selected with parameter P2.24 (selection of operation at OT during homing), stoppage occurs according to parameter P2.60 (third torque limit).

In this case, the homing motion is stopped upon detection of OT.

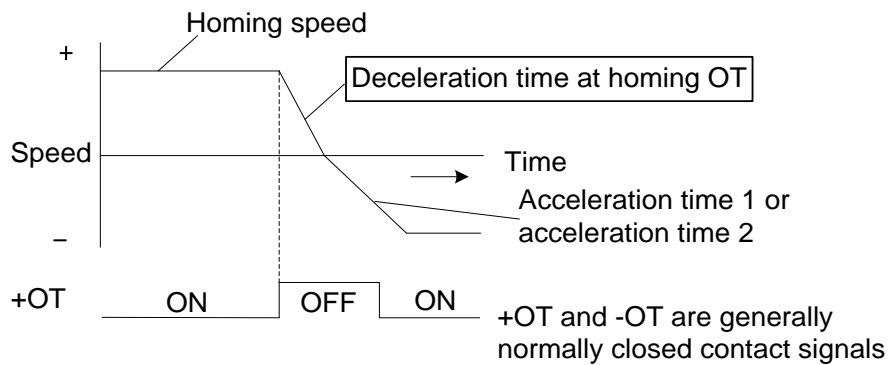

The acceleration time and deceleration time are based on 2000 r/min.

P2.19	Pre-set position	Default value	0
	Setting range	-2000000000 to 2000000000 [Units]	

 Use input signal to specify the modified value (position) of current position ("position pre-set (16) assigned to EI signal")

If the position pre-set signal is turned ON, it says that current position is the setting value of this parameter.

P2.20	Interrupt traveling unit amount	Default value	100000
	Setting range	1 to 2000000000 [Units]	

 Specifies at interrupt positioning

Take the position of timing when input signal ("interrupt input"(49) assigned to EI signal) is turned ON as a standard and specify interrupt traveling unit amount.

P2.22	Detection time for contact-stopper	Default value	0
	Setting range	0~10000 [ms]	
P2.23	Torque limit for contact-stopper	Default value	0
	Setting range	0~100 [%]	

 These parameters are enabled if "5" (stopper) is selected for P2.11 (Reference signal for shift operation).
 Enter these parameters to perform homing in applications such as positioning of a cylinder or the like where the home position LS or +/-OT cannot be used.
 Enter the detection time and the torque limit on contact with the stopper.

*P2.24	Selection of operation at OT during homing	Default value	0
	Setting range	0: Reverse rotation 1: Stop and cancel the homing	

 Specify the motion taken upon first OT detection during homing motion.
 Specify 0 to reverse the motion upon first OT detection.
 Specify 1 to cancel homing and stop upon detection of OT.
 Selection of operation at OT detection during homing =0

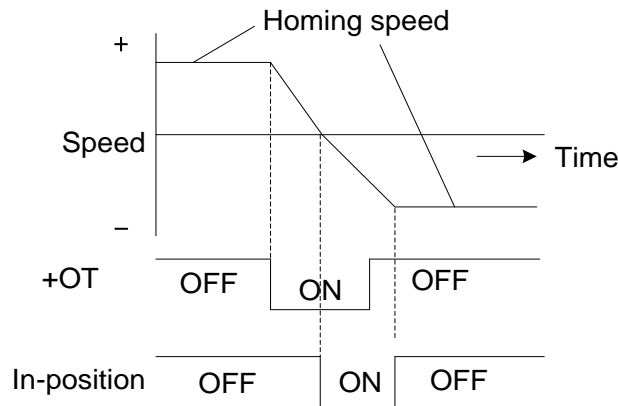

Selection of operation at OT detection during homing =1

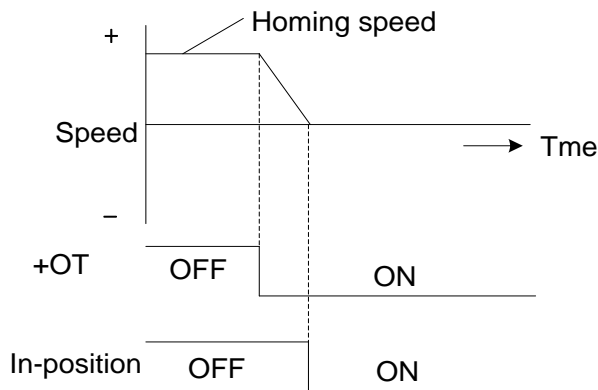

Parameters related to homing

◆The parameters with “*” indicate that they are enabled only when power on again after parameter setting.

Parameters	Name	Setting range	Default value
P2.06	Homing speed	0.01 [r/min]~Max. rotation speed [r/min]	500.00
P2.07	Homing creeping speed	0.01 [r/min]~Max. rotation speed [r/min]	50.00
P2.08	Starting direction for homing	0: Forward 1: Reverse 2: Starting conditional judgment	0
P2.09	Reverse traveling unit amount for homing	0 to 2000000000 [Units]	0
*P2.10	Homing direction	0: Forward rotation direction 1: Reverse rotation direction	0
*P2.11	Reference signal for shift operation	0: Homing position LS 1: Encoder-Z-phase 2: +OT 3: -OT 4: Interrupt input 5: Stopper	1
*P2.12	Reference signal for homing	0: Homing position LS 1: +OT 2: -OT	0
*P2.13	Home position LS signal edge selection	0: ON Rising edge 1: OFF Rising edge	0
P2.14	Home position shift unit amount	0 to 2000000000 [Units]	1000
*P2.15	Deceleration operation for creep speed	0: Reverse rotation is disabled 1: Reverse rotation is enabled	0
P2.16	Home position after homing completion	-2000000000 to 2000000000 [Units]	0
P2.17	Home position detection range	0: Always ON after homing completion 1 to 2000000000 [Units]	0
P2.18	Deceleration time at OT during homing	0.0 to 99999.9 [ms]	100.0
P2.22	Detection time for contact-stopper	0~10000 [ms]	0
P2.23	Torque limit for contact-stopper	0~100 [%]	0
*P2.24	Selection of operation at OT during homing	0: Reverse rotation 1: Stop (suspend)	0

SDV3 can combine parameter settings to create the desired homing profile.

The homing profile is configured with combination of the following parameters.

(1) Starting direction for homing

Specify the starting direction (forward/reverse rotation) of homing. The direction opposite to the homing direction after reference signal detection can be specified.

(2) Homing direction

Select the side of the home position (forward or reverse rotation side) in relation to the reference signal for homing (Deceleration starting signal) and reference signal for shift operation.

(3) Reference signal for shift operation

Select the signal serving as the direct standard of the zero position. You can select +OT or -OT.

(4) Reference signal for homing

Specify the creep speed deceleration signal that is used if the encoder Z-phase is selected as a reference signal for shift operation. You can select LS, +OT or -OT. When the encoder Z-phase is selected, it becomes the creep speed from the start of homing operation.

• Homing profile setting procedure

The basic procedure for specifying the homing profile (homing parameter) is described.

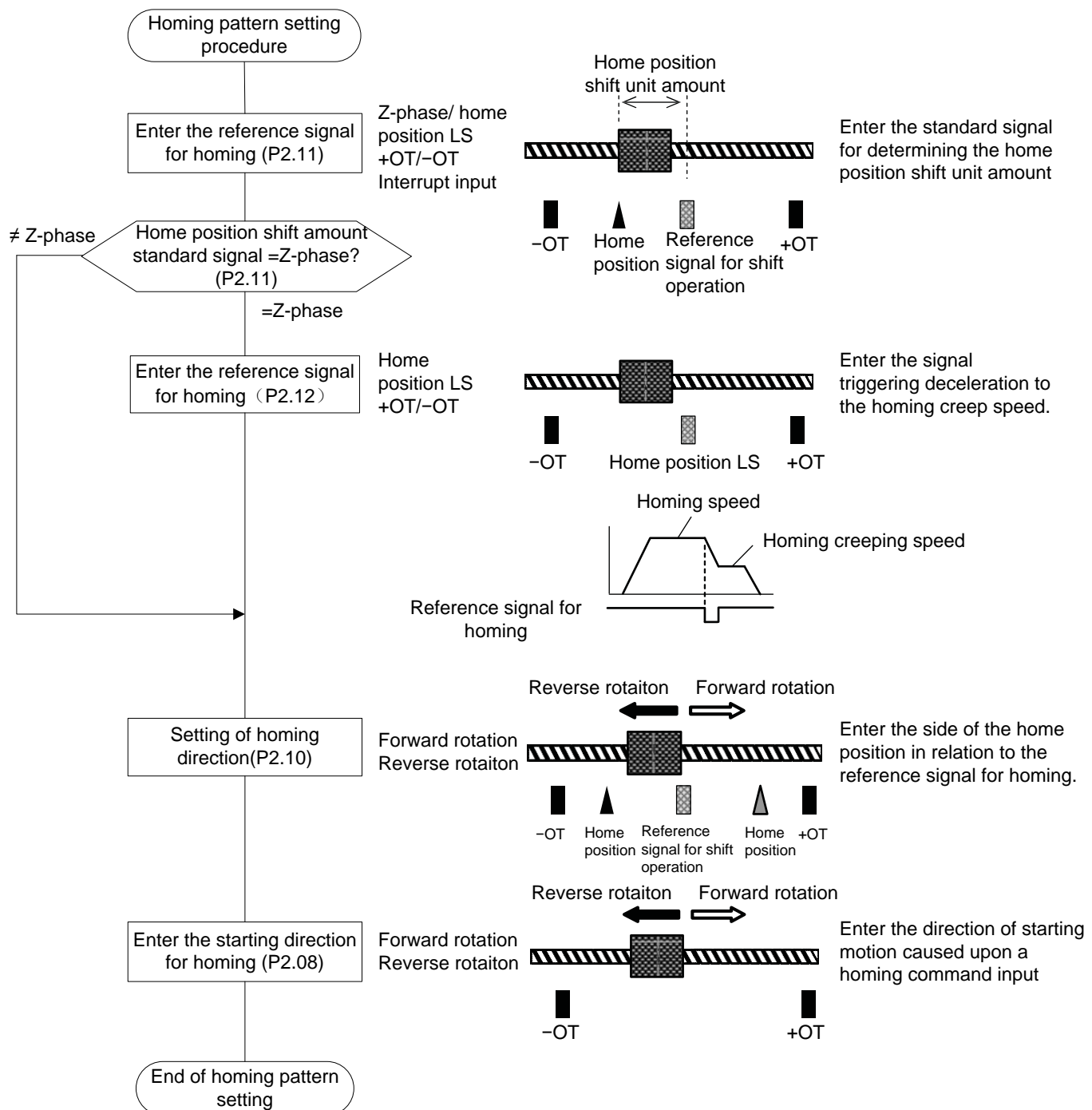

- Basic homing profile

Described here is the homing profile of the most basic motion, in which homing is started, the reference signal for homing (deceleration starting signal) is detected and deceleration to the creep speed for homing occurs, and the reference signal for shift operation is detected and movement by the home position shift unit amount is caused until the motion is stopped.

Use the profile if the machine stopping position is less than the reference signal for homing (deceleration starting signal) or reference signal for shift operation.

Because neither +OT nor -OT is installed for homing of a rotating body as an indicator of the traveling limit, this homing profile is used in principle.

[Parameter setting example]

Parameters	Name	Setting range	Default value
*P1.01	Control mode selection	6: Extension mode	0
P2.06	Homing speed	500.00 [r/min]	500.00
P2.07	Homing creeping speed	50.00 [r/min]	50.00
*P2.08	Starting direction for homing	0: Forward rotation	0
P2.09	Reverse traveling unit amount for homing	0 [Units]	0
*P2.10	Homing direction	0: Forward rotation direction	0
*P2.11	Reference signal for shift operation	1: Encoder Z-phase	1
*P2.12	Reference signal for homing	0: Home position LS	0
*P2.13	Home position LS signal edge selection	0:ON Rising edge	0
P2.14	Home position shift unit amount	1000 [Units]	1000
*P2.15	Deceleration operation for creep speed	0: Reverse rotation is disabled	0
P2.16	Home position after homing completion	0 [Units]	0
P2.17	Home position detection range	0: Always ON after homing completion	0
P2.18	Deceleration time at OT during homing	100.0 [ms]	100.0
*P2.24	Selection of operation at OT during homing	0: Reverse rotation	0

- To cancel homing upon detection of +OT or -OT, specify 1 (stop) to parameter P2.24 (selection of operation at OT during homing).

The motion proceeds in the following procedure:

- (1) The motion starts upon homing [ORG] (OFF → ON) in the starting direction for homing (P2.08) at homing speed (P2.06).
- (2) When the home position LS (P2.12, P2.13) is detected, the motion changes in the homing direction after reference signal detection (P2.10) at the creep speed for homing (P2.07).
- (3) After the home position LS (P2.12) is detected during travel in the homing direction after reference signal detection and the first encoder Z-phase (P2.11) is detected, a travel occurs by the home position shift unit amount (P2.14), followed by stoppage. The stopping point changes to the home position and homing completion is turned on and the homing process is finished.

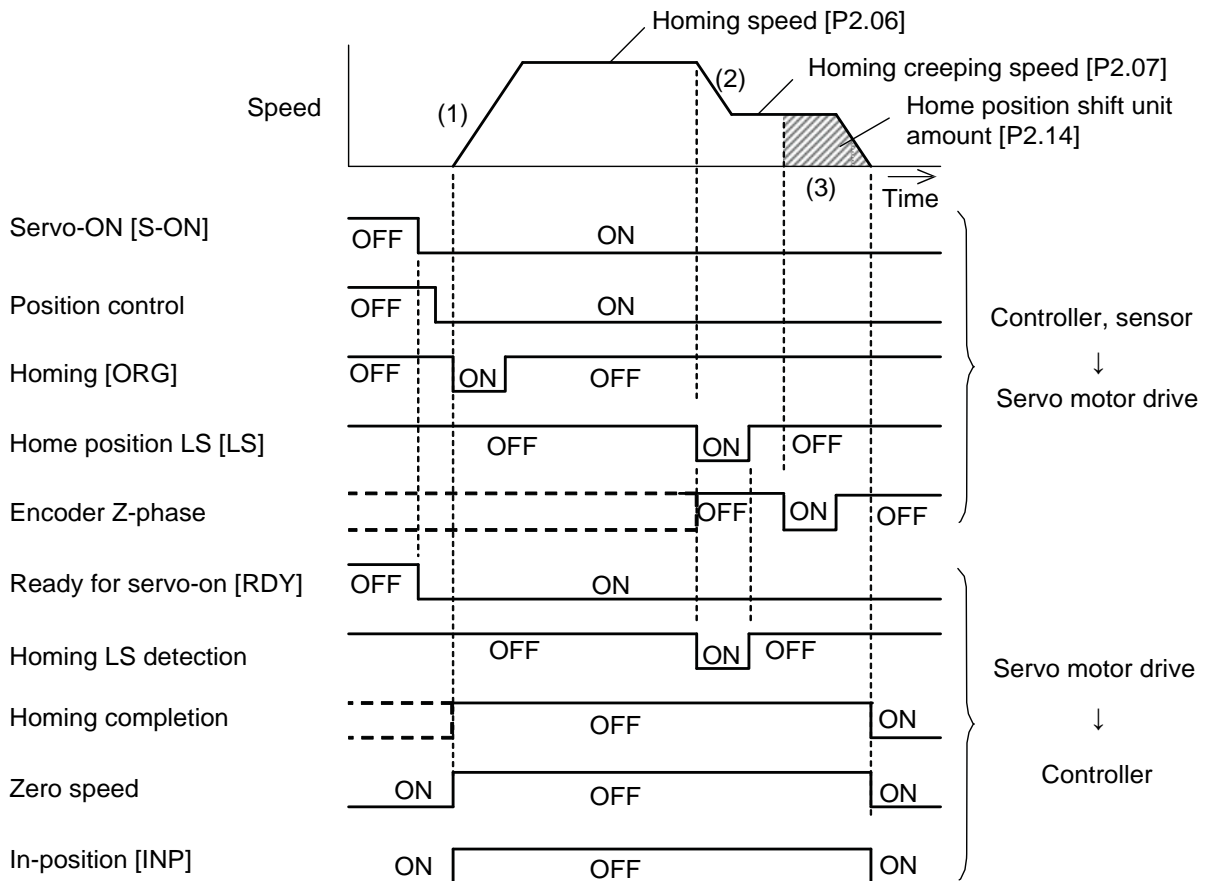
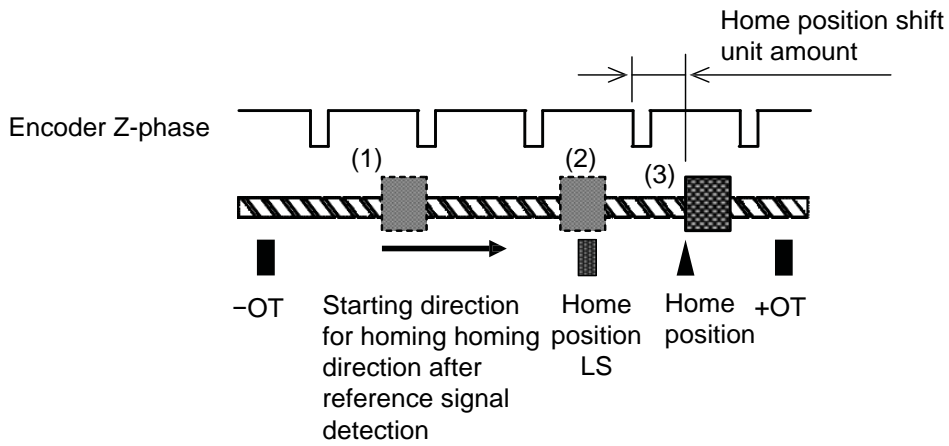

*P2.25	Software OT selection(P1.01 = 1 to 6)	Default value	0
	Setting range	0: Disable 1: Enable	
*P2.25	Position command format (P1.01 = 7)	Default value	0
	Setting range	0: Normal PTP 1: Positioning start with zero position preset	
P2.26	Positive software OT detection position	Default value	2000000000
P2.27	Negative software OT detection position	Default value	-2000000000
	Setting range	-2000000000 to 2000000000 [Units]	

(1) Software OT selection

Forced stop is caused, different from +OT or -OT external input signal, if the servomotor position exceeds the reference value.

Enter settings so that positive software OT detection position is larger than negative software OT detection position.

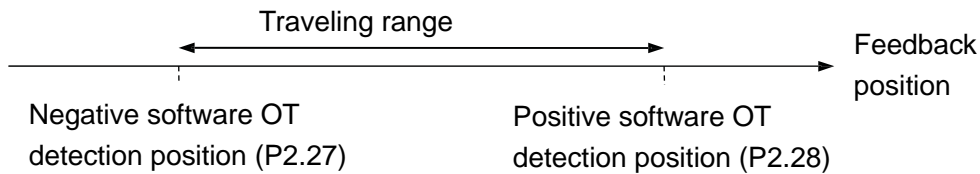

(2) Position command format

Normal PTP: Motion is conducted in the range from -2000000000 to 2000000000 units.

Absolute/incremental positioning data designation and various position detection functions can be used.

Positioning start with zero position preset: Repetitive rotation in the same direction can be made.

The position is preset at the start, and all position data is handled as an incremental value (INC).

The OT function, software OT and hardware OT functions allocated to input signals are disabled.

P2.28	Positive limiter detection position	Default value	2000000000
P2.29	Negative limiter detection position	Default value	-2000000000
	Setting range	-2000000000 to 2000000000 [Units]	

Enter the position of the limiter detection function.

While each setting can be positive or negative, the setting of P2.28 must not be smaller than the setting of P2.29.

P2.31	Point detection, area detection	Default value	0
	Setting range	0: Point detection 1: ON for positive side 2: ON for negative side	
P2.32	Point detection, area detection position 1	Default value	0
P2.33	Point detection, area detection position 2	Default value	0
	Setting range	-2000000000 to 2000000000 [Units]	
P2.34	Point detection range	Default value	100
	Setting range	0 to 2000000000 [Units]	

Specify the output format of the "point detection, area detection" signal that is output as an output signal (EOUT signal).

In case of point detection setting, the signal is output if the servomotor is located nearly in the reference value (point detection range)

In case of area setting, the signal is turned on or off if the servomotor position exceeds the reference value.

(1) Point detection (If P2.31 (point detection, area detection) is 0)

The signal is turned on if the current position is nearly the position specified in the standard parameter.

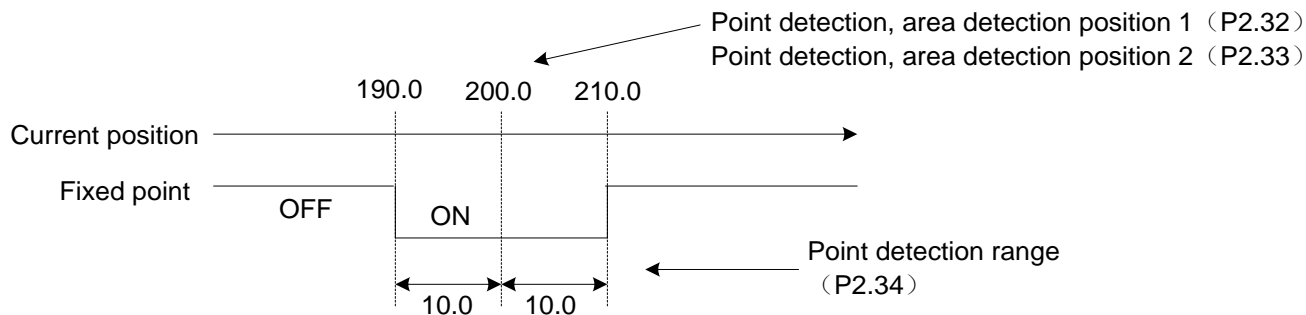

(2) Area OFF → ON (If P2.31 (point detection, area detection) is 1)

The signal is turned on if the current position is exactly or larger than the setting of the standard parameter. It is turned off if the position is less than the setting.

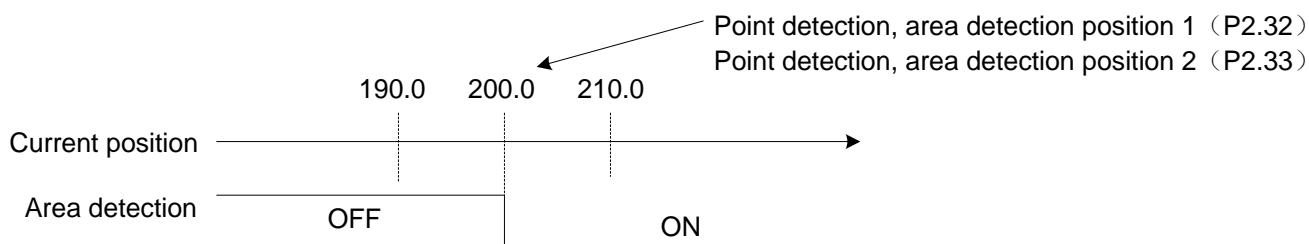

(3) Area ON → OFF (If P2.31 (point detection, area detection) is 2)

The signal is turned on if the current position is exactly or less than the setting of the standard parameter. It is turned off if the position exceeds the setting.

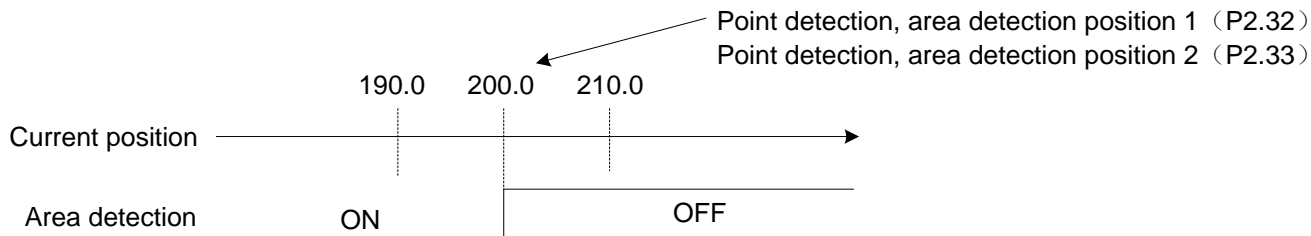

P2.36	Override 1	Default value	10
P2.37	Override 2	Default value	20
P2.38	Override 4	Default value	40
P2.39	Override 8	Default value	80
	Setting range	0~150 [%]	

These parameters are enabled under speed and position control.

To use these signals, be sure to turn on "override enable."

With this setting, the speed can be changed during operation. For the weight of the override, refer to the table below.

Override 8	Override 4	Override 2	Override 1	Traveling speed (%)
OFF	OFF	OFF	OFF	0
OFF	OFF	OFF	ON	10
OFF	OFF	ON	OFF	20
OFF	OFF	ON	ON	30
OFF	ON	OFF	OFF	40
OFF	ON	OFF	ON	50
OFF	ON	ON	OFF	60
OFF	ON	ON	ON	70
ON	OFF	OFF	OFF	80
ON	OFF	OFF	ON	90
ON	OFF	ON	OFF	100
ON	OFF	ON	ON	110
ON	ON	OFF	OFF	120
ON	ON	OFF	ON	130
ON	ON	ON	OFF	140
ON	ON	ON	ON	150

*P2.40	Internal positioning data selection	Default value	0
	Setting range	0: Disable 1: Enable	

 Select whether the internal positioning data is enabled or disabled.

Setting "0": Immediate value data operation over RS-485 Modbus communications.

Setting "1": Positioning data operation with address settings AD3 to AD0

*P2.41	Sequential start selection	Default value	0
	Setting range	0: Disable 1: Enable 2: Homing 3: Immediate value data operation	

 Select whether to enable the sequential start or not, and select the motion when AD0 through AD3 are inactive.

If "1" is selected and AD0 through AD3 are inactive, sequential start operation is conducted.

If "2" is selected and AD0 through AD3 are inactive, homing is conducted.

If "3" is selected and AD0 through AD3 are inactive, immediate value data operation is conducted.

P2.42	Decimal point position of stand still timer	Default value	0
	Setting range	0: 0.01 1: 0.001	

 Select the least input increment of the stand still timer.

Selection can be made between 1 and 10 ms.

*P2.43	Output selection at M code OFF	Default value	1
	Setting range	0: 00'H	1: FF'H

 Select the output signal status at M code shutoff.

*P2.44	Positioning extended function	Default value	0
	Setting range	0: Internal command completion 1: Internal feedback completion	

 Select the condition for reversing in a case “when the travel directions between two continuous motions are opposite” as the followings:

- (a) In continuous operation by the immediate continuous command in immediate data operation
- (b) In continuous operation with the step mode = CO (continuous) and the stop timer = “0” in positioning data operation

Setting value: 0 (Internal command completion.)

After the command in-position of each motion, next operation will be carried out continuously (in continuous operation) as shown in the chart below.

The current feedback position while continuous operation is carried out may not reach the target position due to delay of following behavior.

To approach the target position, adjust the tuning setting and increase the response.

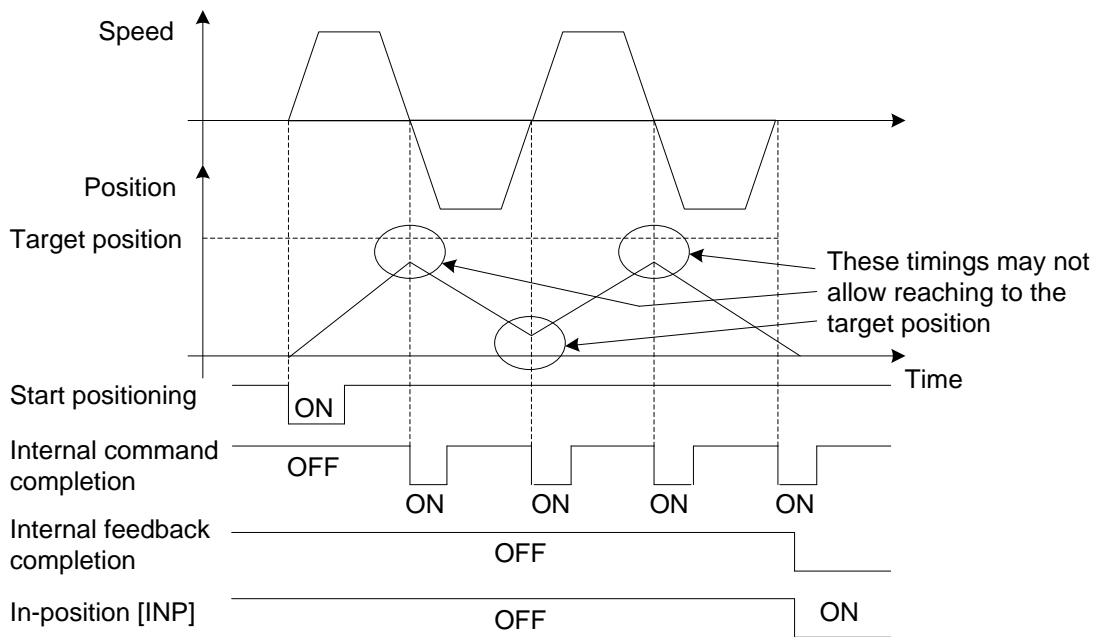

Setting value: 1 (Internal feedback completion.)

The operation will shift to the next motion continuously after each motion enters in-position conditions (※) as shown in the chart below.

The current feedback position while continuous operation is carried out will start the following motion to the target position after positioning is complete normally.

※Conditions for in-position is all of the following (a), (b) and (c).

- (a) Internal command completion;
- (b) The position deviation is within the deviation zero range (P1.32);
- (c) The speed is within the zero speed range (P1.30)

Moreover, the in-position [INP] signal is not output during continuous operation.

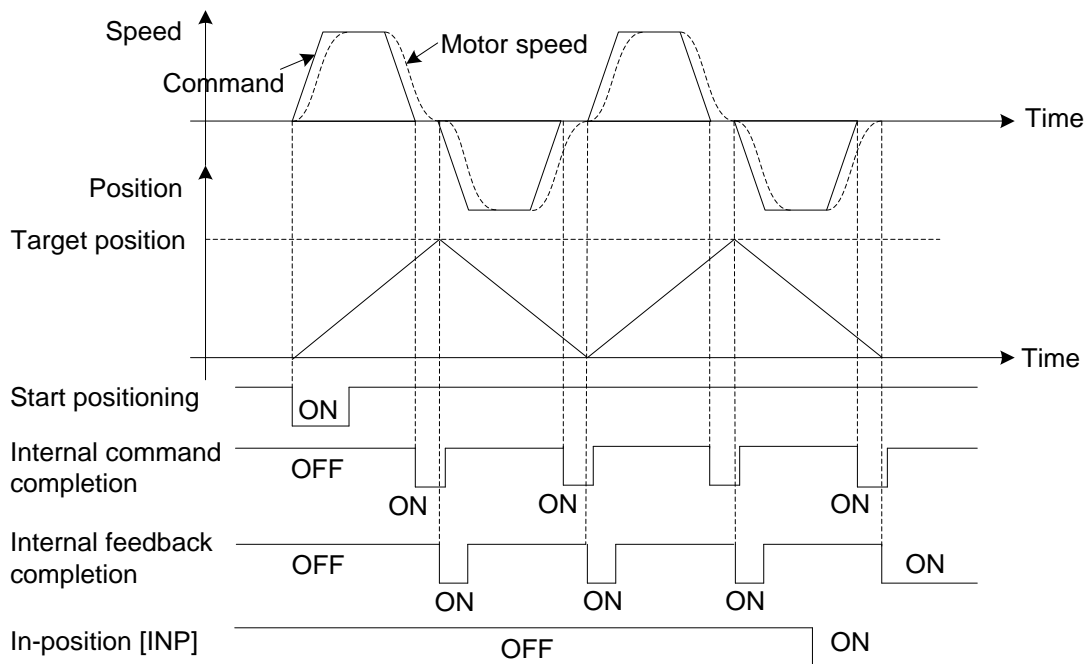

6.4 Extended Function Setting Parameters (P2.51~99)

◆The parameters with "*" indicate that they are enabled only when power on again after parameter setting.

P2.51	Numerator 1 of electronic gear	Default value	1
P2.52	Numerator 2 of electronic gear	Default value	1
P2.53	Numerator 3 of electronic gear	Default value	1
	Setting range	1~4194304	

📖 Specify the electronic gear ratio, using the input signal ("electronic gear numerator selection 0, 1" assigned to EI signal).

Electronic gear numerator selection 1	Electronic gear numerator selection 0	Numerator of electronic gear
OFF	OFF	P1.06 Numerator 0 of electronic gear
OFF	ON	P2.51 Numerator 1 of electronic gear
ON	OFF	P2.52 Numerator 2 of electronic gear
ON	ON	P2.53 Numerator 3 of electronic gear

Do not change the electronic gear ratio in case of interrupt positioning or homing.

P2.54	Command pulse ratio 1	Default value	1.00
P2.55	Command pulse ratio 2	Default value	10.00
	Setting range	0.01~100.00	

📖 Specify the multiplication of the command pulse.

The reference value selected with an input signal ("command pulse ratio 1, 2" assigned to a EI signal) is enabled.

This function is only enabled in extended mode and positioning operation mode(P1.01 = 6 or 7)

*P2.56	Speed limit selection at torque control	Default value	0
	Setting range	0: Parameter (P1.26) 1: As per multi-step speed selection inc. VREF terminal voltage	

 Select the method of setting limitation on the speed under torque control.

If the setting is 0, the reference value of P1.26 (maximum rotation speed) is the speed limit.

If the setting is 1, the limit is shown in the table below.

EI input signal			Enabled speed limit
X3	X2	X1	
OFF	OFF	OFF	VREF
OFF	OFF	ON	Speed limit 1 under torque control
OFF	ON	OFF	Speed limit 2 under torque control
OFF	ON	ON	Speed limit 3 under torque control
ON	OFF	OFF	Speed limit 4 under torque control
ON	OFF	ON	Speed limit 5 under torque control
ON	ON	OFF	Speed limit 6 under torque control
ON	ON	ON	Speed limit 7 under torque control

*P2.57	Torque limit selection	Default value	0
	Setting range	0: As per EI signal torque limit 0/1 1:TREF terminal voltage	
P2.58	Second torque limit	Default value	300
	Setting range	0~300 [%]	
*P2.59	Deviation hold selection at torque limit	Default value	0
	Setting range	0: No deviation hold 1: Deviation hold at second torque limit 2: TREF terminal voltage	
P2.60	Third torque limit	Default value	300
	Setting range	0~300 [%]	

The enabled torque limit is described below.

(1) In case of position control and speed control (If P2.57 is 0).

EI signal		State of each limit	Enabled torque limit	
Torque limit 1	Torque limit 0	TL:TREF(analog torque limit)	CCW: Powering, CW: Regeneration	CW: Powering CCW: Regeneration
OFF	OFF	No condition judgment	Forward rotation torque limit	Reverse rotation torque limit
OFF	ON	TL ≥ Forward/Reverse rotation torque limit	Forward rotation torque limit	Reverse rotation torque limit
		TL < Forward/Reverse rotation torque limit	TL	TL

EI signal		State of each limit	Enabled torque limit	
ON	OFF	Second torque limit \geq Forward/Reverse rotation torque limit	Forward rotation torque limit	Reverse rotation torque limit
		Second torque limit < Forward/Reverse rotation torque limit	Second torque limit	Second torque limit
ON	ON	TL \geq Second torque limit	Second torque limit	Second torque limit
		TL < Second torque limit	TL	TL

Add a positive voltage to TL. The negative voltage is limited to zero.

If P2.57 is 1, the torque limit is always the TL value.

(2) In case of torque control

The forward rotation torque limit and reverse rotation torque limit are followed.

(3) Torque limit for controlled stop action (under position or speed control) (If P2.57 is 0)

EI signal		State of each limit	Enabled torque limit	
Torque limit 1	Torque limit 0	TL:TREF(analog torque limit)	CW deceleration stop	CCW deceleration stop
OFF	OFF	Forward/Reverse rotation torque limit \geq Third torque limit	Third torque limit	Third torque limit
		Forward/Reverse rotation torque limit < Third torque limit	Forward rotation torque limit	Reverse rotation torque limit
OFF	ON	TL, forward/reverse torque limit \geq Third torque limit	Third torque limit	Third torque limit
		TL, forward/reverse torque limit < Third torque limit	TL or forward rotation torque limit, whichever is less	TL or reverse rotation torque limit, whichever is less
ON	OFF	Second torque limit, forward/reverse rotation torque limit \geq Third torque limit	Third torque limit	Third torque limit
		Second torque limit, forward/reverse rotation torque limit < Third torque limit	Second torque limit or forward rotation torque, whichever is less	Second torque limit or reverse rotation torque, whichever is less
ON	ON	TL, second torque limit \geq Third torque limit	Third torque limit	Third torque limit
		TL, second torque limit < Third torque limit	TL or second torque limit, whichever is less	TL or second torque limit, whichever is less

If P2.57 is 1, the torque limit is always the TL value.

(4) Third torque limit

This parameter is enabled under position or speed control.

The reference value of this parameter becomes the torque limit under the following conditions.

- Sudden controlled stop caused by servo-on (function NO.1) turned off.
- Sudden controlled stop caused by forced stop (function NO.10) turned off.
- Sudden controlled stop caused by \pm OT (function NO.7 or 8) turned off.
- Controlled stop caused by minor failure alarm (If P2.62 is 4 or 5).

(5) Deviation holds selection at torque limit

This parameter is enabled under position control.

Position deviation is held with this function after a contact stop. Position deviation is held so that the position deviation count does not reach the limit at the contact stop.

The function is enabled under the following conditions. (If P2.57 is 0).

EI signal		P2.59 Deviation hold selection at torque limit	Torque limit for holding deviation
Torque limit 1	Torque limit 0		
OFF	OFF	—	None
OFF	ON	1: Second torque limit	None
		2:TREF terminal voltage	TL
ON	OFF	1: Second torque limit	Second torque limit
		2:TREF terminal voltage	None
ON	ON	1: Second torque limit	Second torque limit
		2:TREF terminal voltage	TL

If P2.57 is 1 and P2.59 is 2, TL is TREF.

【Reference example】

Example: Timing chart

To hold deviation at TL (TREF) (Torque limit 1 = OFF, Torque limit 0 = ON)

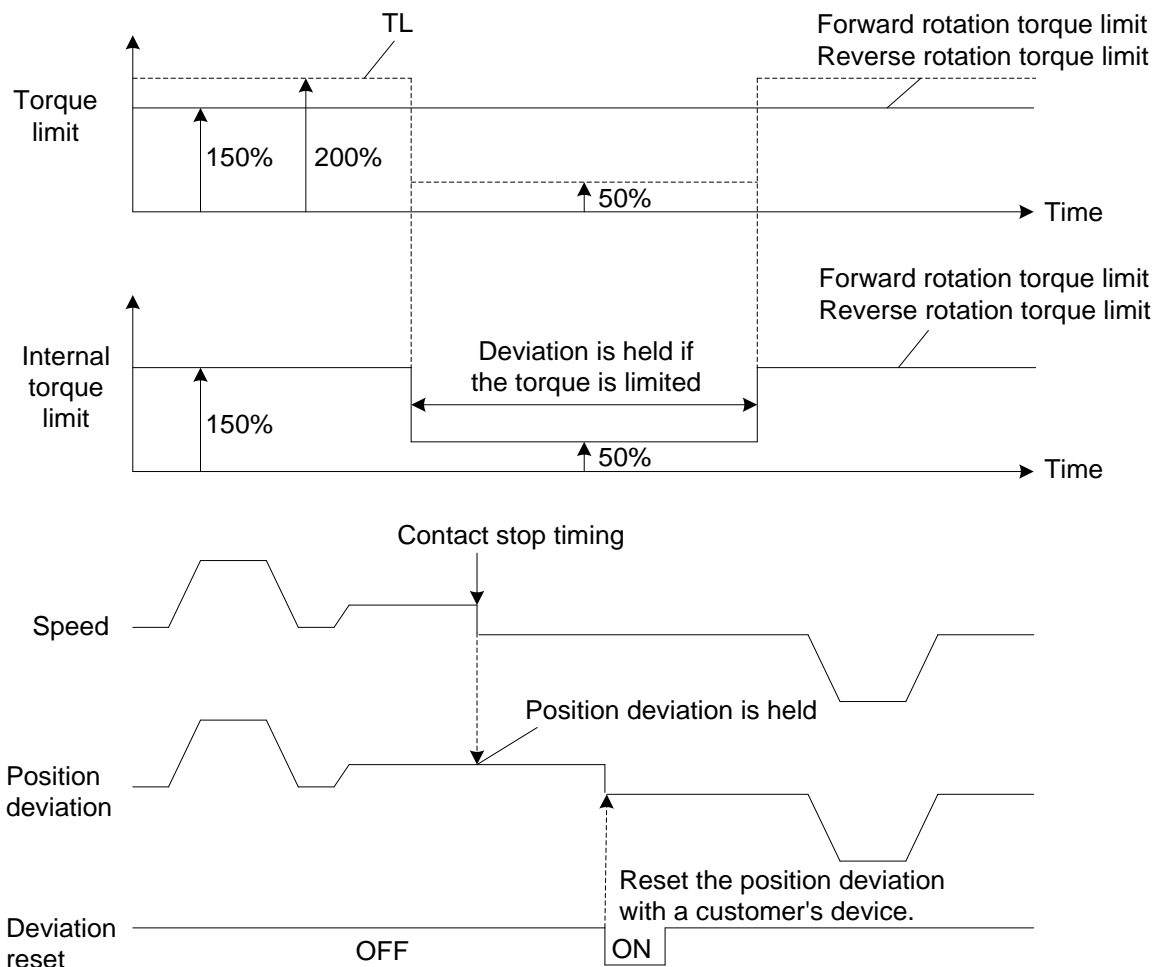

*P2.61	Action state at servo-on OFF	Default value	5
	Setting range	3: Free-run at deceleration, free-run at stop 5: Emergency stop at deceleration , free-run at stop	
*P2.62	Action state at alarm	Default value	5
	Setting range	3: Free-run at deceleration, free-run at stop 5: Emergency stop at deceleration (*1), free-run at stop	
*P2.63	Action state at main power shutoff	Default value	5
	Setting range	3: Free-run at deceleration, free-run at stop 5: Emergency stop at deceleration , free-run at stop	

 (*1) Free-run causes deceleration upon major failure alarm.

Specify the deceleration and stopping states for each condition as shown in the previous table.

P2.64	Torque keeping time to holding brake	Default value	0.00
	Setting range	0.00~9.99 [s]	

 Assign the "brake output (Function NO.14)" signal to the output signal.

The reference value of this parameter indicates the delay taken from shutoff of servo-on (Function NO.1) to free-run.

Specify a time larger than the one taken from excitation of the brake to actual brake application.

The brake output signal is turned off when servo-on is turned off.

*P2.66	Flying start at speed control	Default value	0
	Setting range	0: No flying start 1: Flying start	

 The parameter is enabled under speed control.

If servo-on is turned on during free-run operation, the speed at the timing is picked and acceleration begins at the speed.

The speed at the timing of power-on is not picked in this case.

*P2.67	Alarm detection at undervoltage	Default value	1
	Setting range	0: No detection 1: Detection	

 Select whether or not to detect alarms when undervoltage is detected.

The detected alarms include main power undervoltage.

P2.69	Deviation detection overflow value	Default value	15.0
	Setting range	0.1~100.0 [rev]	

 Specify the value for detecting a "deviation overflow" alarm.

Enter the parameter in a rotation amount of the motor output shaft.

P2.70	Overload warning value	Default value	50
	Setting range	10~100 [%]	

Specify the output level of the "overload warning (27) signal that is issued as an output signal (EOUT signal). Use the signal as a warning of an "overload (OL)" alarm.

- Standard series

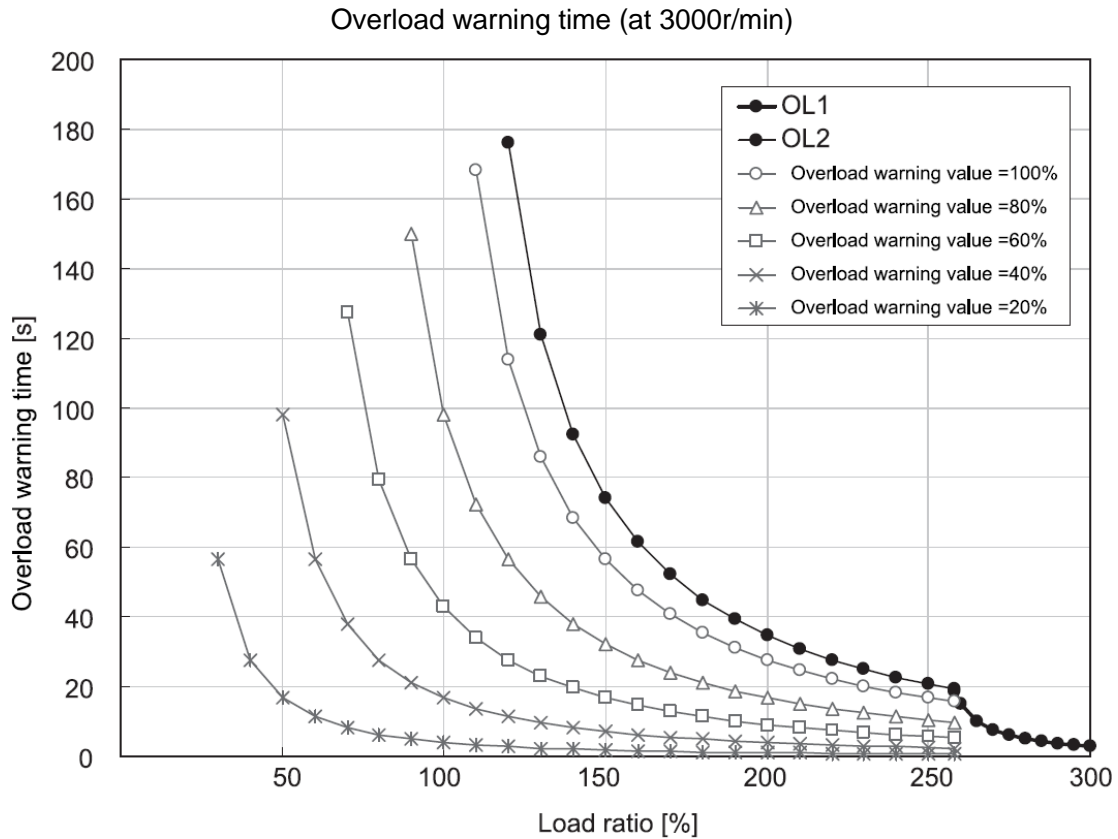

*P2.72	Station number	Default value	1
	Setting range	Station number:1~31	

Specify the station number of RS485 communication.

*P2.73	Communication baud rate (RS485)	Default value	0
	Setting range	0: 38400 [bps] 1:19200 [bps] 2: 9600 [bps] 3:115200 [bps] 4: 57600 [bps] 5: 4800 [bps] 6: 2400 [bps] 7: 1200 [bps]	

Specify the communication baud rate of the system combined over RS-485.

P2.74	Parameter write protection	Default value	0
	Setting range	0: Write enable 1: Write protect	

Specify parameter write protection.

Enter "1" to prohibit parameter editing. Only this parameter can be changed.

P2.75	Positioning data write protection	Default value	0
	Setting range	0: Write enable 1: Write protect	

 Specify positioning data write protection.

Enter "1" to prohibit positioning data editing.

*P2.77	Initial display of the keypad	Default value	0
	Setting range	0: Action mode 1: Feedback speed 2: Command speed 3: Command torque 4: Motor current 5: Peak torque 6: Effective torque 7: Feedback position 8: Command position 9: Position deviation 10: Command pulse frequency 11: Feedback cumulative pulse 12: Command cumulative pulse 13: LS-Z pulse 14: Load inertia ratio 15: DC link voltage (max.) 16: DC link voltage (min.) 17: VREF input voltage 18: TREF input voltage 19: Input signals 20: Output signals 21: OL thermal value 41: Alarm at present 42: Alarm history	

 Specify the data displayed on the servo motor drive when the power is turned on.

*P2.80	Parameter in RAM 1	Default value	0
*P2.81	Parameter in RAM 2	Default value	0
*P2.82	Parameter in RAM 3	Default value	0
*P2.83	Parameter in RAM 4	Default value	0
*P2.84	Parameter in RAM 5	Default value	0
*P2.85	Parameter in RAM 6	Default value	0
	Setting range	0 :No setting 1~99 :P1.01~99 101~199 :P2.01~99 201~299 :P3.01~99 301~399 :P4.01~99	

 If you change some parameters frequently, store them in RAM. With this setting, you can change parameters infinitely.

Parameters that can be stored in RAM are those marked "Always" in the "Change" field.

The parameter stored in RAM is in the default value when the amplifier is turned on.

[Setting example] 1 to 99 = P1.01 to 99, 101 to 199 = P2.01 to 99, 201 to 299 = P3.01 to 99.

*P2.86	Positioning data in RAM 1	Default value	0
*P2.87	Positioning data in RAM 2	Default value	0
*P2.88	Positioning data in RAM 3	Default value	0
	Setting range	0: No setting 1~15 : Positioning data No.	

 If you change positioning data frequently, store them in RAM. With this setting, you can change positioning data infinitely.

The positioning data stored in RAM is in the default value when the amplifier is turned on.

*P2.89	Sequence test mode: mode selection	Default value	0
	Setting range	0: Normal mode 1: Sequence test mode	
P2.90	Sequence test mode: Encoder selection	Default value	0
	Setting range	0: 20bit 1: 18bit 2: 17bit	

 P2.89 = 0:

Select 0 to start the sequence test mode from the keypad.

Turn the power off then on again to return to the normal mode.

Specify the encoder bit according to the type of the servo motor.

P2.89 = 1:

Select 1 to always start the sequence test mode.

To return to the normal mode, change P2.89 to 0 and turn the power off then on again.

Specify the encoder bit according to the type of the servomotor.

P2.90: Specify the parameter according to the connected motor encoder bit.

*P2.93	Parity/stop bit selection	Default value	0
	Setting range	0: 8,E,1 1: 8,O,1 2: 8,N,1 3: 8,E,2 4: 8,O,2 5: 8,N,2	

 Set existence and logic of a parity and a stop bit length.

P2.94	Response time	Default value	0.00
	Setting range	0.00~1.00 [s] (※)	
P2.95	Communication time over	Default value	0.00
	Setting range	0.00 [s]: No detection 0.01~9.99 [s]	

 ※The actual response time is the setting of P2.94 or the sum of {time of 3 characters + servo motor drive's } processing time}, whichever is longer.

Specify the response time and communication time over according to the requirement.

P2.97	Communication protocol selection	Default value	1
	Setting range	0: Reserved 1:Modbus RTU(HL) 2:Modbus RTU(LH) 5:Host computer protocol	

 Modbus RTU (HL): When accessing 32-bit data, the data content is arranged in the order in which the high word precedes the low word.

Modbus RTU (LH): When accessing 32-bit data, the data content is arranged in the order of the low word in the first high word.

Host computer protocol: Used when communicating with the host computer software Savch-Soft_SRV on the PC side.

*P2.99	Encoder selection	Default value	1
	Setting range	0:20 bit 4:20 bit (With battery) 1:17 bit 5:17 bit (With battery)	

 Specify the encoder according to the encoder bit number according to the actual motor. Please make sure that the setting is correct, otherwise, the motor may not rotate in normal operation.

6.5 Input Terminal Function Setting Parameters (P3.01~50)

◆The parameters with "*" indicate that they are enabled only when power on again after parameter setting.

*P3.01	E11 signal assignment	Default value	1
*P3.02	E12 signal assignment	Default value	11
*P3.03	E13 signal assignment	Default value	0
∟	∟	Default value	0
*P3.05	E15 signal assignment	Default value	0
	Setting range	Select from EI signal assignment function	

*P3.09	Communication E19 signal assignment	Default value	0
∟	∟	Default value	0
*P3.24	Communication E124 signal assignment	Default value	0
	Setting range	Select from EI signal assignment function	

(1) Input terminal (EI input signal) list

Select the input terminal function assigned to the EI signal in the table below.

The number and the function have one-on-one relationship. To specify a desired function, assign the corresponding number to the EI input signal (EI1 to EI6).Communication data setting is enabled from EI9 through EI24.

However, the setting of "49" (interrupt input) must be assigned to from EI5.

No.	Name	No.	Name	No.	Name
1	Servo-on [S-ON]	23	Immediate value change	48	Interrupt input enable
2	Forward command [FWD]	24	Electronic gear numerator selection 0	49	Interrupt input
3	Reverse command [REV]	25	Electronic gear numerator selection 1	50	Deviation clear
4	Start positioning [START]	26	Command pulse inhibit	51	Multi-step speed selection 1[X1]
5	Homing [ORG]	27	Command pulse ratio 1	52	Multi-step speed selection 2[X2]
6	Home position LS[LS]	28	Command pulse ratio 2	53	Multi-step speed selection 3[X3]
7	+OT	29	Proportional control	54	Free-run
8	-OT	31	Pause	55	Edit permission
10	Forced stop [EMG]	32	Positioning cancel	57	Anti resonance frequency selection 0
11	Alarm reset [RST]	35	Teaching	58	Anti resonance frequency selection 1
14	ACC0	36	Control mode selection	60	AD0
16	Position preset	37	Position control	61	AD1
17	Servo response switch	38	Torque control	62	AD2
19	Torque limit 0	43	Override enable	63	AD3
18	Communication speed selection	44	Override 1	69	External terminal alarm
20	Torque limit 1	45	Override 2	70	Pulse speed command
21	Communication torque selection	46	Override 4	77	Positioning data selection
22	Immediate value continuation	47	Override 8	78	Broadcast cancel

The logic of the following signals differs between those assigned to hardware EI signals (EI 1 to 6) and those to communications EI signals (EI 9 to 24).

No.	Name	Signal logic	
		Hardware EI signal: assigned to (EI1 to 6)	Communications EI signal: assigned to (EI 9 to 24)
7	+OT	Normally closed contact	Normally open contact
8	-OT	Normally closed contact	Normally open contact
10	Forced stop [EMG]	Normally closed contact	Normally open contact

(2) Connector pin layout (CN2)

The pin layout of each signal is shown in the figure below.

Assign desired functions to signals EI1 through EI6.

Signal Name	PIN NO.
EI1	24
EI2	6
EI3	15
EI4	14
EI5	4
EI6	20
COM	5

(3) Detailed description of Input signal function

•Servo-ON [S-ON] (Reference value 1)

The signal makes the servomotor ready to rotate.

The servo motor is ready to rotate while the servo-on [S-ON] signal remains turned on.

When the servo-on signal is turned off, the gate for IGBT is turned off and the servomotor does not rotate. At this time, the servomotor is in free-run and all rotation commands are ignored.

If the signal is turned off during rotation, controlled stop is caused according to the setting of P2.61 (action state at servo-on OFF). The stopping profile follows the setting of P2.61, too.

If there is no alarm, activation of servo-on [S-ON] and forced stop [EMG] arranges the state ready to rotate.

If no signals are assigned on the EI input terminals, it is always regarded as turning ON.

•Forward command [FWD]:(Reference value 2)

•Reverse command [REV]:(Reference value 3)

The servo motor keeps rotating during the signals on.

The servo motor keeps rotating in the positive (negative-) direction while the forward command [FWD] (reverse command [REV]) signal remains turned on. Acceleration begins at the rising edge, while the trailing edge triggers deceleration.

If no signal is assigned on the EI input terminals, it is always regarded as turning OFF.

•Start positioning [START]: (Reference value 4)

Positioning motion is executed according to positioning data or immediate value data sent via RS-485 communications.

This function is enabled only if parameter P1.01 is "7" (positioning operation).

The positioning motion starts at the activating edge of the start positioning signal.

If P2.40 (internal positioning data selection) is "1" (enable), the internal positioning data is enabled. Positioning is made according to positioning addresses AD0 through AD3.

If P2.40 (internal positioning data selection) is "0" (disable), positioning is made according to the position data and speed data sent via RS-485 communications.

Check for the active state of the in-position signal (level) to turn the start positioning signal on. The motor starts to rotate. After rotation begins, the in-position signal is turned off.

If no signal is assigned on the EI input terminals, it is always regarded as turning OFF.

·Homing [ORG]: (Reference value 5)

·Home position LS [LS]: Reference value 6)

A homing motion is executed and the home position is determined.

These functions are enabled only if the extension mode (parameter P1.01= 6) and the positioning operation (parameter P1.01=7) are selected.

The rising edge of the homing signal starts a homing motion.

The homing motion follows the settings of P2.06 through P2.18.

·Over-travel in positive direction [+OT]: (Reference value 7)

·Over-travel in negative direction [-OT]: (Reference value 8)

These signals are input signals of the limit switch which prevents the over travel (OT) at the end in the machine travel direction.

Each signal is always enabled except under torque control.

If the over-travel signal is turned off, controlled stop is caused within the limit specified in P2.60 (third torque limit).

If an OT signal is detected during positioning operation, the servomotor is forcibly stopped and therefore difference may be caused between the command position and feedback position.

Take care of the reference value and sensor position so that the OT signal will not be detected during regular operation.

If no signal is assigned on the EI input terminals, it is always regarded as turning OFF.

·Forced stop [EMG]: (Reference value 10)

This signal is used to forcibly stop the servo motor.

The servo motor is forcibly stopped while the forced stop [EMG] signal remains turned off.

This signal is enabled in all control modes and it is given the highest priority. Because the safety and detection speed are significant, the forced stop signal is generally connected to the servo amplifier directly.

A self-locked pushbutton switch (command switch) provided on the operation panel or similar is connected in regular cases.

If forced stop is turned off during operation, controlled stop is caused within the limit specified in P2.60 (third torque limit).

If no signal is assigned on the EI input terminals, it is always regarded as turning ON.

·Alarm reset [RST]: (Reference value 11)

The alarm reset signal resets alarm detection of the servo motor drive.

The rising edge of the alarm reset [RST] signal resets alarm detection.

If no signal is assigned on the EI input terminals, it is always regarded as turning OFF.

·ACC0:(Reference value 14)

ACC0 switches the acceleration/deceleration time.

The acceleration time and deceleration time of the servo motor follow the setting of P1.37 to 40 (acceleration time, deceleration time). The acceleration time and deceleration time can be set separately.

The setting through ON/OFF of the ACC0 signal despite the direction of rotation, as shown in the table below can be switched.

ACC0	Acceleration time	Deceleration time
OFF	P1.37	P1.38
ON	P1.39	P1.40

If no signal is assigned on the EI input terminals, it is always regarded as turning OFF.

·Position preset: (Reference value 16)

The command position and feedback position are preset (overwritten).

The command position and the feedback position are made the reference value of P2.19 (preset position) at the rising edge. However, the deviation is subtracted from the feedback position.

The rising edge is the change point at which the EI input signal having been switched off to on.

As zero speed signal [NZERO] can be performed during ON, it is recommended to conduct position preset while the servomotor is stopped. After position preset, homing is finished.

If no signal is assigned on the EI input terminals, it is always regarded as turning OFF.

·Servo response switch: (Reference value 17)

To switch the gain (response capability) of the servo system.

When P1.61 (Gain switch cause) is set at "3" (external switch: EI signal), the EI signal assigned to this function switches the gain of the servo system.

The control gain parameters that are enabled with the servo response switch are listed in the table below.

Use the function to change the gain of the servo system between the going path and returning path in a reciprocal motion or similar.

Servo response switch	Control gain
OFF	P1.55: Position loop gain 1
	P1.56: Speed loop gain 1
	P1.57: Speed loop integration time constant 1
	P1.58: Feed forward gain 1
ON	P1.64: Position loop gain 2
	P1.65: Speed loop gain 2
	P1.66: Speed loop integration time constant 2
	P1.67: Feed forward gain 2

If no signal is assigned on the EI input terminals, it is always regarded as turning OFF..

·Communication speed selection: (Reference value 18)

Switch the source of speed command in position control mode and speed control mode.

When the current multi-stage speed selection [X1], [X2] and [X3] are all OFF, and the pulse speed command (function code 70) is OFF, this signal is ON, and the speed is controlled by the communication speed command (communication address 0x3000). , the signal is OFF, the speed is controlled by the speed command voltage (VREF).

·Torque limit 0: (Reference value 19)

·Torque limit 1: (Reference value 20)

Limitations are set on the output torque of the servo motor.

Limitation on the output torque of the servomotor by turning on the torque limit signal can be set.

Specify the torque limit in increments of 1% in the range from "0" to the maximum output torque.

The maximum output torque is 300% if the rated torque is 100%.

The torque limit function is always enabled in all control modes.

Note that the setting of P1.37 to 40 (acceleration and deceleration time) may be ineffective if the output torque is limited during acceleration or deceleration.

·Communication torque selection: (Reference value 21)

Switch the source of torque command in torque control mode.

When the signal is ON, the torque is controlled by the communication torque command (communication address 0x3002). When the signal is OFF, the torque is controlled by the torque command voltage (TREF).

The unit of the communication torque command is the rated torque percentage.

If this signal is not assigned to the EI signal input terminal, it is handled as always OFF.

·Immediate value continuation: (Reference value 22)

Positioning motion can be continued according to the next data from the target position (speed) started in the immediate value mode.

This function is enabled only if "7" (positioning operation) is selected for parameter P1.01.

After immediate value operation starts with the first data, supply desired data in an immediate value continuation command. Operation continues with the next data, following execution of the first data.

·Immediate value change: (Reference value 23)

The target position and target speed of immediate value start can be changed at an arbitrary timing.

This function is enabled only if "7" (positioning operation) is selected for parameter P1.01.

After immediate value operation is started and the in-position signal is turned off, the target position and target speed can be changed at an arbitrary timing.

Even if the positioning motion of the first data is not finished, the next data is executed immediately when the change command is accepted.

The command position and command speed change at the rising edge of the immediate value change command. They can be changed at an arbitrary timing while the in-position signal remains inactive.

·Electronic gear numerator selection 0: (Reference value 24)

·Electronic gear numerator selection 1: (Reference value 25)

These are used to change the multiplication of the traveling amount of the mechanical system.

Switch electronic gear numerator 0 or electronic gear numerator 1 to select one of four command pulse offsets.

The numerator of the electronic gear can be changed through these functions assigned to the EI input signal, as shown in the table below.

Electronic gear numerator selection 1	Electronic gear numerator selection 0	Enabled electronic gear numerator selection
OFF	OFF	P1.06: Numerator 0 of electronic gear
OFF	ON	P2.51: Numerator 1 of electronic gear
ON	OFF	P2.52: Numerator 2 of electronic gear
ON	ON	P2.53: Numerator 3 of electronic gear

If no signal is assigned on the EI input terminals, it is always regarded as turning OFF.。

·Command Pulse inhibit: (Reference value 26)

The pulse input in the position control mode is enabled or disabled.

The command pulse is not accepted while the command pulse inhibit signal remains turned on.

If no signal is assigned on the EI input terminals, it is always regarded as turning OFF.。

Therefore, in this case, only when the servo-ON [S-ON] is turned ON, the pulse input will be always enabled.

·Command pulse ratio 1: (Reference value 27)

·Command pulse ratio 2: (Reference value 28)

Use the parameters to change the multiplication of the command input pulse under position control in the extension mode.

These functions are enabled only if "6" (extension mode) or "7" (positioning operation) is selected for parameter P1.01.

To perform pulse operation in the extension mode (mode compatible with conventional α Series), be sure to assign command pulse ratio 1 or command pulse ratio 2 to a CONT input signal.

Turn servo-on, position control and command pulse ratio 1 (2) on to enable pulse operation.

If command pulse ratio 1 is turned on, the ratio set at P2.54 (command pulse ratio 1) is enabled.

If command pulse ratio 2 is turned on, the ratio set at P2.55 (command pulse ratio 2) is enabled.

$$\text{Number of input pulses} \times \frac{\text{Numerator 0 to 3 of electronic gear ratio}}{\text{Denominator of electronic gear ratio}} \times \text{Command pulse ratio} = \text{Pulse of encoder}$$

If no signal is assigned on the EI input terminals, it is always regarded as turning OFF.。

·Proportional control: (Reference value 29)

Proportional band control is adopted as a servo motor drive control method.

With S-ON signal turned on, the signal will be turned on while the servo motor shaft is mechanically locked.

If the proportional control is turned on during servo motor rotation, position control becomes unstable.

If the brake is applied under position control with the servo locked, an overload (oL) alarm is detected.

Be sure to turn off P motion before applying the brake from an external unit.

If no signal is assigned on the EI input terminals, it is always regarded as turning OFF.。

·Pause: (Reference value 31)

This signal temporarily stops the start positioning, homing motion and interrupt positioning motion.

Deceleration starts at the rising edge of the pause signal (31). While the signal is turned on, the start positioning, homing and interrupt positioning motions are interrupted and stopped. After the signal is turned off, the remaining motion continues.

The signal is ineffective to pulse ratio 1, pulse ratio 2, and manual forward and reverse rotation.

Deceleration follows the designated acceleration/deceleration time, different from forced stop (10).

The pause is enabled to the current positioning motion.

If no signal is assigned on the EI input terminals, it is always regarded as turning OFF.。

·Positioning cancel: (Reference value 32)

This signal is used to cancel the auto start, homing motion, and interrupt positioning motion on the way. To resume homing motion, turn on the positioning cancel signal and then turn on the homing signal again.

The interrupt positioning motion cancels the interrupt positioning motion after interrupt input is turned on.

This function is disabled for the pulse operation.

Unlike forced stop, controlled stop will be conducted within the selected deceleration time.

If no signal is assigned on the EI input terminals, it is always regarded as turning OFF.。

·Teaching: (Reference value 35)

The current position of the servo motor is written to the position data in the positioning data.

This function is enabled only if "7" (positioning operation) is selected for parameter P1.01.

The command current position of the servomotor is written to the position data in the positioning data at the rising edge of a teaching signal.

The status of the position is absolute (ABS).

The signal can be always executed without relations to the status of the forced stop and servo-on signals.

Teaching is executed generally according to the following procedure.

- (1) Designate the address of positioning data, to which the current position is to be written, among AD0 to AD3.
- (2) Using the manual forward rotation command, pulse operation or the like, feed the mechanical system to the target position.
- (3) The command current position of the servomotor is written to the position data in the positioning data at the rising edge of a teaching signal.

If no signal is assigned on the EI input terminals, it is always regarded as turning OFF.。

·Control mode selection: (Reference value 36)

To switch the control mode by setting the sequence input signal ON/OFF.

This function is to be used to switch to the control mode (control state) during servo motor operation.

Control mode selection is enabled only if P1.01 (control mode selection) is set at 3, 4 or 5.

The enabled control mode includes the following.

P1.01: Control mode selection	Control mode switch	
	OFF	ON
3	Position control	Speed control
4	Position control	Torque control
5	Speed control	Torque control

If no signal is assigned on the EI input terminals, it is always regarded as turning OFF.。

·Position control: (Reference value 37)

To be used to conduct position control (positioning by pulse) in the extension mode.

This function is enabled only if "6" (extension mode) is selected for parameter P1.01.

Turn on to perform position control in the extension mode.

Positioning, interrupt positioning and other functions can be executed with a pulse input.

If no signal is assigned on the EI input terminals, it is always regarded as turning OFF.

[Example] To conduct operation with a command pulse input

Operation with a command pulse input is enabled while command pulse ratio 1 or command pulse ratio 2 remains turned on after the position control signal is turned on.

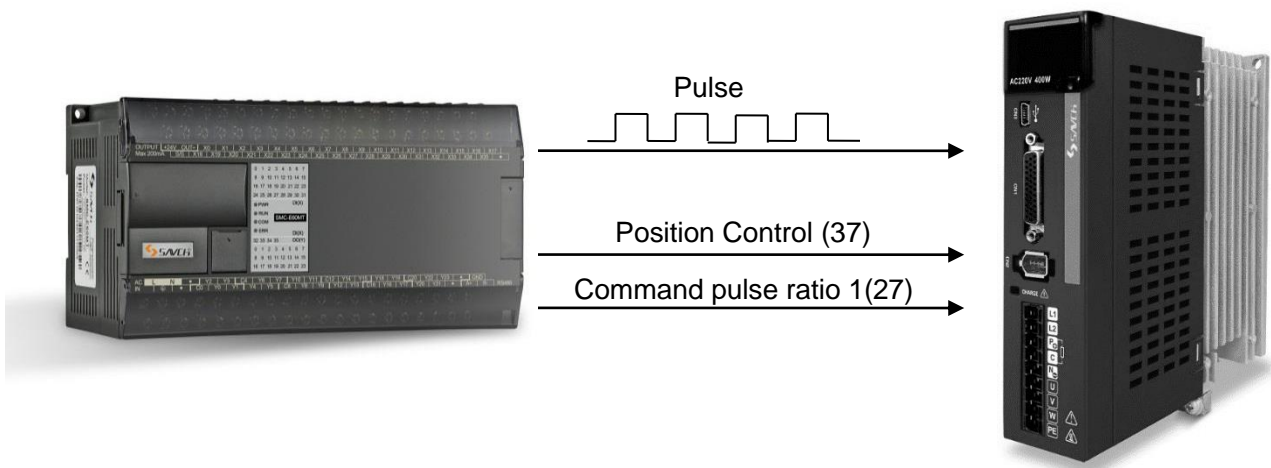

The conditions for enabling position control with the command pulse input are shown below:

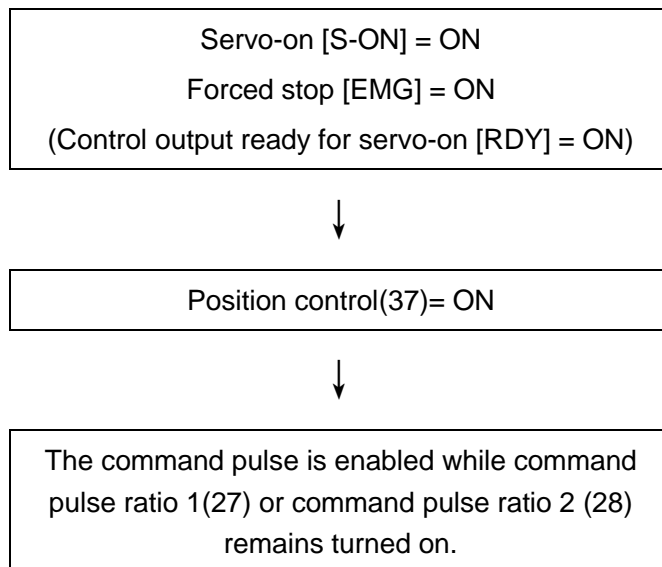

·Torque control: (Reference value 38)

Use to conduct torque control in the extension mode.

This function is enabled only if "6" (extension mode) is selected for parameter P1.01.

Turn on to conduct torque control in the extension mode.

The torque of the output shaft of the servo motor can be controlled.

The torque is actually output while the forward command [FWD] or reverse command [REV] signal remains turned on.

Besides, the rotation direction depends on the different forward command [FWD] or reverse command [REV] signal.

The torque command value depends on the input voltage applied to the TREF terminal. (Refer to the table below.)

Voltage applied to TREF terminal	Output torque (rated torque 100%)
±3[V]	±100[%]*

*P3.33: If the torque command scale value is the default value.

If no signal is assigned on the EI input terminals, it is always regarded as turning OFF. .

·Override enable:(Reference value 43)

·Override 1:(Reference value 44)

·Override 2:(Reference value 45)

·Override 4:(Reference value 46)

·Override 8:(Reference value 47)

The rotation speed of the servomotor can be changed during operation.

The rotation speed can be changed with the multiplication designated with override 1/2/4/8 while the override enable signal remains turned on.

The speed can be increased up to 150% of the current rotation speed (within the maximum rotation speed).

The weight of the multiplication corresponding to override 1/2/4/8 can be changed with the parameter.

This parameter is enabled for all rotation commands except for torque control and command pulse input (command pulse ratio 1/2).

If no signal is assigned on the EI input terminals, it is always regarded as turning OFF.

·Interrupt input enable: (Reference value 48)

·Interrupt input: (Reference value 49)

Use to realize the interrupt positioning function.

These functions are enabled only if "6" (extension mode) or "7" (positioning operation) is selected for parameter P1.01.

These functions are enabled with the forward command [FWD] / reverse command [REV], positioning data operation, and immediate value operation.

If the interrupt input enable signal assigned to a EI input signal is turned on, stoppage is caused after a travel of a certain amount since the interrupt input signal is turned on.

Specify the traveling amount after the interrupt input in P2.20 (interrupt traveling unit amount).

The rotation speed after an interrupt input keeps the speed at the rising edge effective.

The override is enabled even after the rising edge.

To change the rotation speed in the interrupt positioning mode, use the override.

If no signal is assigned on the EI input terminals, it is always regarded as turning OFF.。

Note: Interrupt input can only be assigned to EI5

·Deviation clear: (Reference value 50)

The difference (deviation) between the command position and feedback position is zeroed.

The command position changes to the feedback position.

Use P3.36 (deviation clear input form) to select either the edge or level signal.

If the edge is selected, deviation is reset at the rising edge.

The activation time must be 2 ms or over.

All rotation commands are ignored while the deviation clear signal is turned on.

If the deviation clear signal is turned on during servomotor rotation, the manual forward rotation [FWD] signal and so on are ignored.

The feedback position does not change even if deviation clear is executed.

You can zero the accumulated deviation due to the mechanical stop or similar, thereby avoiding the travel by the deviation amount that may appear when the load is released.

If no signal is assigned on the EI input terminals, it is always regarded as turning OFF.。

·Multi-step speed selection [X1]:(Reference value 51)

·Multi-step speed selection [X2]:(Reference value 52)

·Multi-step speed selection [X3]:(Reference value 53)

The manual feed speed is specified for the position or speed control mode.

These values are used to select the speed limit in the torque control mode.

The rotation speed while the forward command [FWD] (reverse command [REV]) signal is turned on is selected.

(1) Under speed and position control

The motor turns at the speed selected with multi-step speed [X1], [X2] and [X3].

The setting speed is shown in the table below.

X3	X2	X1	Parameters	Rotation speed for enabling
OFF	OFF	OFF	-	Rotation corresponding to speed command voltage (VREF)
OFF	OFF	ON	P1.41	Manual feed speed 1 / Speed limit under torque control 1
OFF	ON	OFF	P1.42	Manual feed speed 2 / Speed limit under torque control 2
OFF	ON	ON	P1.43	Manual feed speed 3 / Speed limit under torque control 3
ON	OFF	OFF	P1.44	Manual feed speed 4 / Speed limit under torque control 4
ON	OFF	ON	P1.45	Manual feed speed 5 / Speed limit under torque control 5
ON	ON	OFF	P1.46	Manual feed speed 6 / Speed limit under torque control 6
ON	ON	ON	P1.47	Manual feed speed 7 / Speed limit under torque control 7

(2) Under torque control

The rotation speed of the servomotor is limited with the speed selected with multi-step speed [X1], [X2] and [X3].

The speed limit under torque control is shown in the table below.

X3	X2	X1	Parameters	Rotation speed for enabling
OFF	OFF	OFF	-	Rotation corresponding to speed command voltage (VREF)
OFF	OFF	ON	P1.41	Manual feed speed 1 / Speed limit under torque control 1
OFF	ON	OFF	P1.42	Manual feed speed 2 / Speed limit under torque control 2
OFF	ON	ON	P1.43	Manual feed speed 3 / Speed limit under torque control 3
ON	OFF	OFF	P1.44	Manual feed speed 4 / Speed limit under torque control 4
ON	OFF	ON	P1.45	Manual feed speed 5 / Speed limit under torque control 5
ON	ON	OFF	P1.46	Manual feed speed 6 / Speed limit under torque control 6
ON	ON	ON	P1.47	Manual feed speed 7 / Speed limit under torque control 7

If no signal is assigned on the EI input terminals, it is always regarded as turning OFF.

·Free-run [BX]: (Reference value 54)

To put the servo motor forcibly into free-run

Priority is given to this signal in all control modes.

While the free-run [BX] signal assigned to a EI input signal remains turned on, the output of the servo amplifier is shut off and the servomotor free-run.

The output shaft of the servomotor decelerates (accelerates) according to the torque of the load.

The free-run signal is enabled in all control modes (position control, speed control and torque control modes).

Under position control, the number of output pulses sent from the host controller deviates from the revolution amount of the servomotor because the servomotor free-run while the signal remains turned on.

Under speed control and torque control, as the servomotor automatically become free-run.in case it is used for vertical transportation purpose, note that there is a risk of falling.

If no signal is assigned on the EI input terminals, it is always regarded as turning OFF.。

·Edit permission: (Reference value 55)

Editing operation for parameters and so on is limited with an external EI input signal.

The following operation can be executed only while the edit permission remains turned on.

- Parameter edit mode
- Positioning data edit mode
- Additional function mode

When the edit permission assigned to a EI input signal is turned off, only the monitor mode can be executed.

This function can be used to avoid inadvertent operation of the keypad, thereby avoiding movement of the servomotor, drop of the machine, etc.

·Anti resonance frequency selection 0: (Reference value 57)

·Anti resonance frequency selection 1: (Reference value 58)

Select the anti resonance frequency, which is a vibration suppressing control function.

In a spring characteristic structure such as the robot arm and transfer machine, vibration is caused at the end of the workpiece upon sudden acceleration or deceleration of the motor.

Vibration suppressing control aims at suppression of vibration of the workpiece in such a system, thereby realizing positioning at a shorter cycle time.

Four points through combination of anti resonance frequency selection 0 and anti resonance frequency selection 1 can be specified.

The anti resonance point may vary according to the length of the arm and the weight of the load.

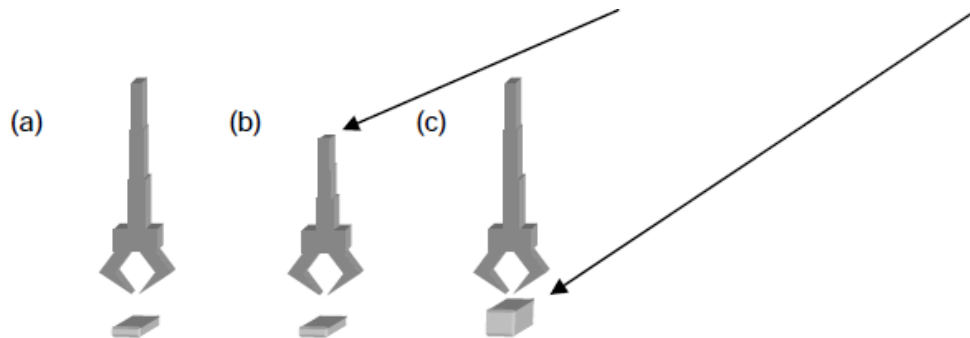

Selection of the anti resonance frequency is shown in the table below.

Anti resonance frequency selection 1	Anti resonance frequency selection 0	Vibration suppressing resonance frequency	Vibration suppressing workpiece inertia ratio
OFF	OFF	P1.78	P1.79
OFF	ON	P1.80	P1.81
ON	OFF	P1.82	P1.83
ON	ON	P1.84	P1.85

If no signal is assigned on the EI input terminals, it is always regarded as turning OFF.

Therefore, P1.78 (vibration suppressing anti resonance frequency 0) is always enabled.

To disable the anti resonance frequency, set the anti resonance frequency at 300.0 Hz.

Because in-cycle switching of the anti resonance frequency causes a shock, switch during stoppage without fail.

In addition, it is recommended to use P1.52 (low-pass filter (for S-curve) time constant) in parallel.

-AD0:(Reference value 60)

-AD1:(Reference value 61)

-AD2:(Reference value 62)

-AD3:(Reference value 63)

Enter the address of positioning data to be followed, among AD0 to AD3.

Refer to the table below when entering.

Address NO.	AD3	AD2	AD1	AD0	Sequential start selection:P2.41	Operation mode
						In case of internal positioning data selection:P2.40 = 1(enable)
0	OFF	OFF	OFF	OFF	0: Disable	Address error
					1: Enable	Sequential start
					2: Homing	Homing operation
					3: Immediate value data operation	Immediate value data operation

Address NO.	AD3	AD2	AD1	AD0	Sequential start selection:P2.41	Operation mode In case of internal positioning data selection:P2.40 = 1(enable)
1	OFF	OFF	OFF	ON	-	Operation with positioning data 1
2	OFF	OFF	ON	OFF	-	Operation with positioning data 2
3	OFF	OFF	ON	ON	-	Operation with positioning data 3
4	OFF	ON	OFF	OFF	-	Operation with positioning data 4
5	OFF	ON	OFF	ON	-	Operation with positioning data 5
6	OFF	ON	ON	OFF	-	Operation with positioning data 6
7	OFF	ON	ON	ON	-	Operation with positioning data 7
8	ON	OFF	OFF	OFF	-	Operation with positioning data 8
9	ON	OFF	OFF	ON	-	Operation with positioning data 9
10	ON	OFF	ON	OFF	-	Operation with positioning data 10
11	ON	OFF	ON	ON	-	Operation with positioning data 11
12	ON	ON	OFF	OFF	-	Operation with positioning data 12
13	ON	ON	OFF	ON	-	Operation with positioning data 13
14	ON	ON	ON	OFF	-	Operation with positioning data 14
15	ON	ON	ON	ON	-	Operation with positioning data 15

-External terminal alarm: (setting value 69)

When the terminal is ON, the drive generates an external terminal alarm (EF), which can be used when there is a need to trigger alarm signal through an external IO terminal.

-Pulse speed command: (setting value 70)

In speed control mode, the speed is controlled by the pulse command frequency.

When the current multi-speed selection [X1], [X2] and [X3] are all OFF, the signal is ON, the speed is controlled by the pulse command frequency, the signal is OFF, and the speed is controlled by the speed command voltage (VREF).

Speed command value (rpm) = input pulse command frequency * 60 * Electronic gear numerator / electronic gear denominator / encoder single-turn resolution.

-Positioning data selection: (Reference value 77)

Positioning data operation and immediate value operation are switched over.

The positioning data can be switched at an arbitrary timing between the following: positioning within 15 points with internal positioning data and positioning with immediate value data for frequent positioning data change.

If the EI signal is turned on, the positioning data is enabled.

if the EI signal is turned off, the immediate value data is enabled.

If no signal is assigned on the EI input terminals, it is always regarded as turning OFF.。

•Broadcast cancel: (Reference value 78)

The command using the broadcasting method via Modbus-RTU communications is canceled.

The Modbus-RTU protocol can issue queries from the host controller, the master, to all the slave stations at the same time. For example, if the servo has a five-axis structure (of A, B, C, D, and E-axes), the servo motor drive at all the stations can be started with positioning simultaneously.

On the other hand, the Modbus-RTU protocol cannot perform the broadcast by allocating a group station no. separately.

For example, if the servo has a five-axis structure (of A, B, C, D, and E-axes), the servo motor drive cannot be started with positioning simultaneously by selecting the A-axis and the B-axis only.

Thus by using this function, the broadcast in a separate group station no. can be performed.

The broadcast enable/disable status can be switched using the broadcast cancel signal.

If no signal is assigned on the EI input terminals, it is always regarded as turning OFF.

Furthermore, if the broadcast cancel signal "78" is assigned to the parameter EI always ON, the broadcast function is kept disabled. (The query of broadcast is always canceled.)

<Logic of broadcast cancel signals>

Broadcast cancel	Broadcast	Uni-cast
Not assigned	Enabled	Enabled
OFF	Enabled	
ON	Disabled Cancels the queries of broadcast, without responding.	

P3.25	Virtual EI input	Default value	0
	Setting range	0~255	

Setting up the On-off states of the EI1 to 8 signal, and the relationship between the setting value and the real EI input signal is OR.

After the set value is converted to binary, Bit0 corresponds to EI1, bit1 corresponds to EI8.

*P3.26	EI always ON 1	Default value	0
*P3.27	EI always ON 2	Default value	0
*P3.28	EI always ON 3	Default value	0
*P3.29	EI always ON 4	Default value	0
*P3.30	EI always ON 5	Default value	0
	Setting range	Specify the number corresponding to desired function (0 to 78)	



Specify the EI input signal that is always enabled after the power is turned on.

The normally open connect signal is always turned on. The normally closed connect signal signal is always turned off.

Functions that may not be specified with a normally open signal include alarm reset, deviation clear and free-run.

Functions that may not be specified with a normally closed signal include forced stop and external regenerative resistor overheat. (Functions that can be specified with a normally closed signal are +OT and -OT.)

For example, to turn forward command [FWD] always on, specify "2," which corresponds to the forward command, to one of EI always ON signals 1 to 5.

The signal assigned to EI input signal can be also assigned to EI always enabled setting redundantly.

P3.31	Speed command scale	Default value	5.0
	Setting range	$\pm 1.0 \sim \pm 100.0$ [V] / Rated rotation speed	
P3.32	Speed command offset	Default value	—
	Setting range	-2000~2000 [mV]	
P3.33	Torque command scale	Default value	3.0
	Setting range	$\pm 1.0 \sim \pm 100.0$ [V] / Rated rotation torque	
P3.34	Torque command offset	Default value	—
	Setting range	-500~500*10[mV]	

Specify the scale (gain) and offset of the analog input signal.

Note: The default value of the analog command will be variable due to hardware change.

Speed command scale (Default value)

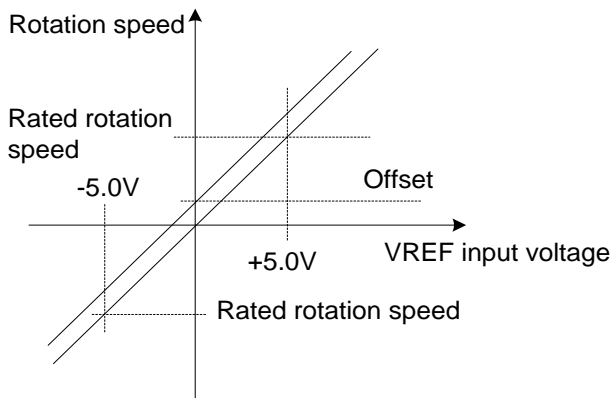

Torque command scale (Default value)

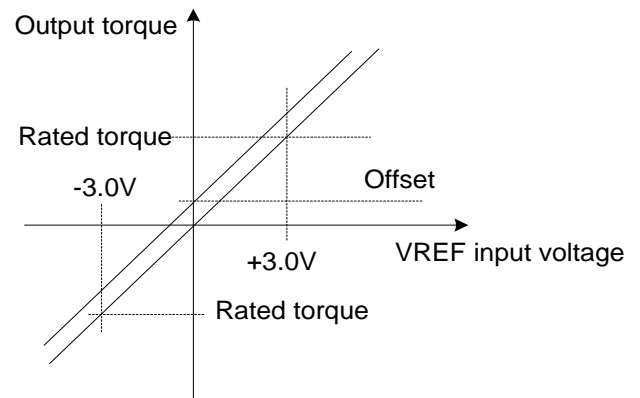

P3.35	Zero clamp level	Default value	0
	Setting range	0~500 [r/min]	

The parameter is enabled under speed or position control.

Rotation speeds less than the specified value are clamped (fixed) at 0r/min.

This parameter is not affected by offsets or similar for the prevention of drifting upon nearly zero speed command input value.

*P3.36	Deviation clear input format	Default value	0
	Setting range	0: Edge 1: Level	

Specify the deviation clear input signal format.

Select 0 (edge) to reset position deviation at the rising edge timing.

When select 1 (electric level), during the deviation clear ON, it stops at the speed zero state and does not maintain the current position.

P3.39	Speed command fine adjustment gain	Default value	1.0000
	Setting range	0.8000~1.2000	

 The gain is finely adjusted in relation to the speed command.

In an X-Y table or similar where two or more servomotor axes are interpolated with analog speed commands, you can make the D/A scale of the host unit match the A/D scale of the servo motor drive.

Interpolation accuracy is improved with this.

[Example]: If the VREF voltage is 5V and P3.39 is 1.0100, the speed command inside the servo motor drive is 5.05V (5 x 1.0100).

P3.40	Torque command fine adjustment gain	Default value	1.0000
	Setting range	0.8000~1.2000	

 The gain can be finely adjusted in relation to the torque command.

The function is similar to that of P3.39 (speed command fine adjustment gain)

[Example]: If TREF voltage is 3V and P3.40 is 1.0100, the torque command inside the servo motor drive is 3.03V (3 x 1.0100).

P3.42	Command pulse filter setting	Default value	3
	Setting range	0~15	

Set the filtering frequency of the instruction pulse.

The correspondence between setting values and filtering frequencies is as follows:

Setting value	Filter frequency	Setting value	Filter frequency	Setting value	Filter frequency	Setting value	Filter frequency
0	15 MHz	4	312.5 KHz	8	78.1 KHz	12	29.3 KHz
1	7.5 MHz	5	234.4 KHz	9	58.6 KHz	13	23.4 KHz
2	3.75 MHz	6	156.3 KHz	10	46.9 KHz	14	19.5 KHz
3	1.875 MHz	7	117.2 KHz	11	39.1 KHz	15	14.6 KHz

P3.49	VREF filter time constant	Default value	0.50
	Setting range	0.00~50.00[ms]	

Set the smoothing time constant of the VREF analog signal.

P3.50	TREF filter time constant	Default value	0.50
	Setting range	0.00~50.00[ms]	

Set the smoothing time constant of the TREF analog signal.

6.6 Output Terminal Function Setting Parameters (P3.51~99)

◆ The parameters with “*” indicate that they are enabled only when power on again after parameter setting.

*P3.51	EOUT1 signal assignment	Default value	1
*P3.52	EOUT2 signal assignment	Default value	2
*P3.53	EOUT3 signal assignment	Default value	76
	Setting range	Select according to the EOUT signal assignment function	

*P3.56	Communication EOUT6 signal assignment	Default value	0
∩	∩	Default value	0
*P3.71	Communication EOUT21 signal assignment	Default value	0
	Setting range	Select according to the EOUT signal assignment function	

(1) Output terminal (EOUT output signal) list

Select the output terminal function assigned to the EOUT signal in the table below.

The number and the function have one-on-one relationship. To specify a desired function, assign the corresponding number to the EOUT output signal (EOUT 1 to 3). Communication data setting is enabled from EOUT6 through EOUT21.

No.	Name	No.	Name	No.	Name
1	Ready for servo-on [RDY]	29	Edit permission response	66	MD6
2	In-position [INP]	30	Data error	67	MD7
11	Speed limit detection	31	Address error	75	Position preset completion
13	Over write completion	32	Alarm code 0	76	Alarm detection (normally closed contact)
14	Brake output	33	Alarm code 1	79	Immediate value continuation permission
16	Alarm detection (normally open contact)	34	Alarm code 2	80	Immediate value continuation completion
17	Point detection, area 1	35	Alarm code 3	81	Immediate value change completion
18	Point detection, area 2	36	Alarm code 4	82	Command position completion
19	Limiter detection	38	+OT detection	83	Range1 of position
20	OT Detection	39	-OT detection	84	Range 2 of position
21	Cycle end detection	40	Home position LS detection	85	Interrupt positioning detection
22	Homing completion	41	Forced stop detection	91	EI20 through
23	Zero deviation	60	MD0	92	EI21 through
24	Zero speed	61	MD1	93	EI22 through
25	Speed coincidence	62	MD2	94	EI23 through
26	Torque limit detection	63	MD3	95	EI24 through

No.	Name	No.	Name	No.	Name
27	Overload warning	64	MD4		
28	Servo control ready [S-RDY]	65	MD5		

(2) Connector pin layout (CN2)

The pin layout of each signal is shown in the figure below.

Assign desired function to signals EOUT1 through EOUT3.

Signal name	Pin NO.
EOUT1	21
EOUT2	22
EOUT3	23
OCM	7

(3) Description of Output signal function

•Ready for servo-on [RDY]: (Reference value 1)

This signal is turned on if the servo motor is ready to operate.

The ready for servo-on signal is turned on if the conditions shown in the table below are satisfied.

Signal division	Signal name	Function No.	Signal status
EI input	Servo-on [S-ON]	1	ON
	Forced stop [EMG]	10	ON
	Free-run [BX]	54	OFF
EOUT output	Alarm detection (Normally open contact)	16	OFF
	Servo control ready [S-RDY]	28	ON

The host controller can check if the servo motor is rotatable or not via the signal [RDY] ON or OFF.

•In-position [INP]: (Reference value 2)

This signal is turned on after a positioning motion is finished.

(1) Status of in-position signal

The state under position control is shown in the table below.

Factor	Sequence status	Status of in-position signal
If servo-on [S-ON] is turned OFF	Free-run	ON
If servo-on [S-ON] is turned ON	Servo lock	ON
Upon OT detection	Servo lock	ON
At deviation clear	Servo lock	ON
If forced stop [EMG] is turned off	Zero speed	ON
Upon alarm	Free-run	OFF

This signal is always turned on under speed control and torque control.

(2) In-position signal output format

P1.33 (in-position output format) at either "0" (level) or "1" (single shot) can be set.

-Speed limit detection: (Reference value 11)

The signal is turned on if the rotation speed of the servomotor reaches the preset speed limit.

Under speed control and position control (except for command pulse operation), the speed limit depends on the setting of P1.25 (maximum rotation speed for position and speed control).

Under torque control, the speed limit depends on the setting of P1.26 (maximum rotation speed for torque control).

However, if P2.56 (speed limit selection at torque control) is "1," the speed limit can be selected with multi-step speed settings X1 to X3.

-Over write completion: (Reference value 13)

This signal is turned on after teaching is made and data is overwritten.

The signal remains turned on while the teaching function enters data.

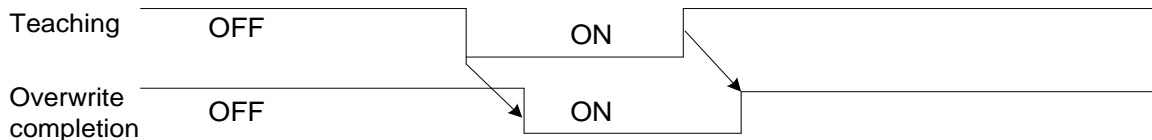

-Brake output: (Reference value 14)

The timing signal for applying or releasing the brake of the servo motor.

The brake output is turned off if the servo-on [S-ON] signal is turned off.

The ready signal is turned off after the torque keeping time to holding brake (P2.64).

Note	<ul style="list-style-type: none"> • The brake attached to the brake-attached servomotor is "for retention".Do not use it for regenerative. • Do not use the IP24 power supply in parallel.Be sure to prepare a separate power supply for the brake. • To apply or release the brake with the brake output, turn the servo-on [S-ON] signal off first before turning the power off.
-------------	--

·Timing chart

(1) ON/OFF of servo-on [S-ON] signal

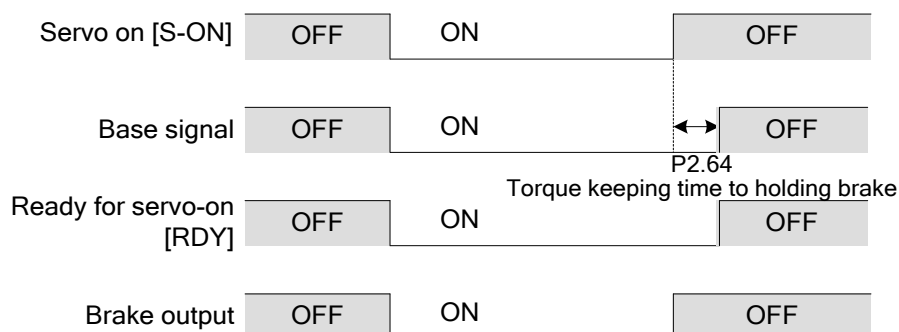

(2) Upon alarm

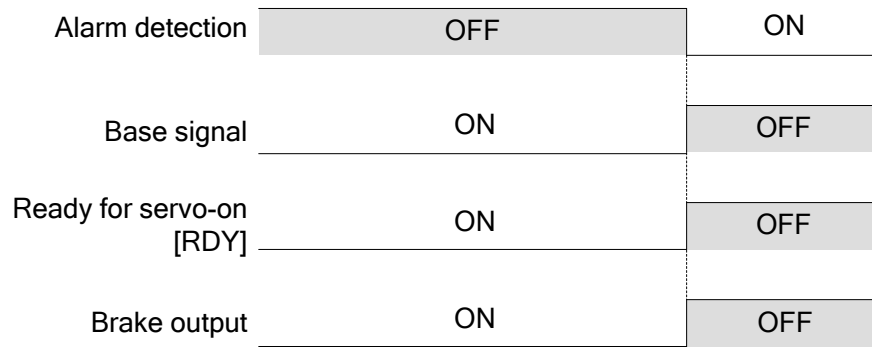

(3) Upon main power supply OFF

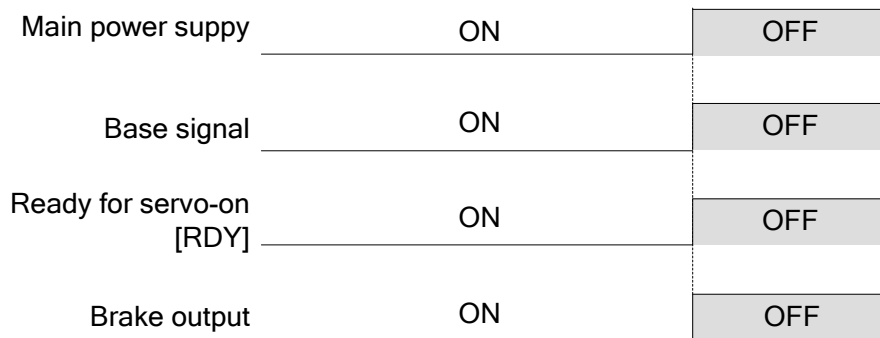

·Alarm detection (normally open contact): (Reference value 16)

·Alarm detection (normally closed contact): (Reference value 76)

These signals are turned on (b contact OFF) if the servo motor drive detects an alarm (protection function operation).

After the cause of the alarm is removed, the signal is turned off (to be ready to operation) upon a rising edge of the alarm reset [RST] signal.

Alarm can be checked by having the host controller recognizes the alarm detection.

Precautions for using a normally closed contact for alarm detection.



The signal will be off for up to 1.5 seconds after the power is turned on.

·Point detection, area 1: (Reference value 17)

·Point detection, area 2: (Reference value 18)

The current position of the servomotor is detected and output in these signals.

This function is enabled after homing or position preset.

Three types of the output format can be selected through settings of P2.31 (point detection, area detection).

(1) P2.31 = 0: point detection

The signal is turned on near the position specified with P2.32 (point detection, area detection 1) or P2.33 (point detection, area detection 2).

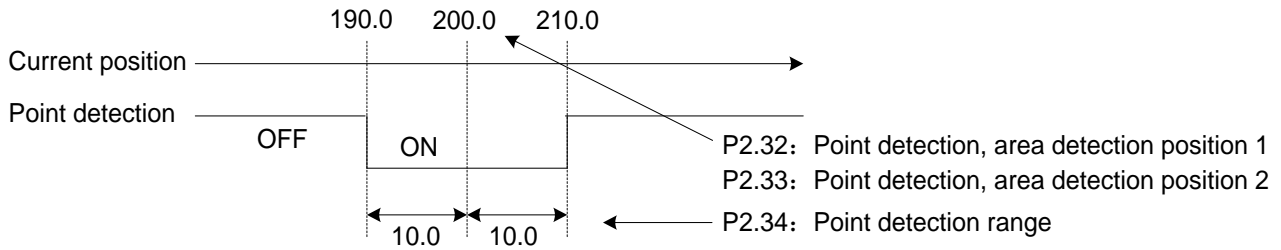

(2) P2.31 = 1: ON for positive side

The signal is turned on at a position beyond the setting of P2.32 or P2.33.

The signal is turned off below the setting

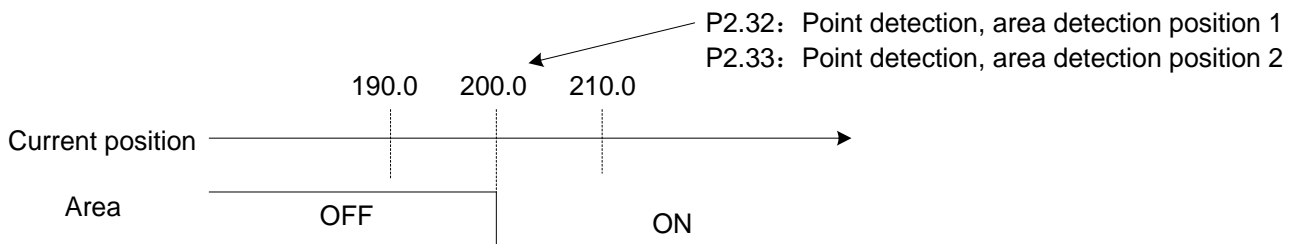

(3) P2.31 = 2: ON for negative side

The signal is turned on below the setting of P2.32 or P2.33.

The signal is turned off beyond the setting

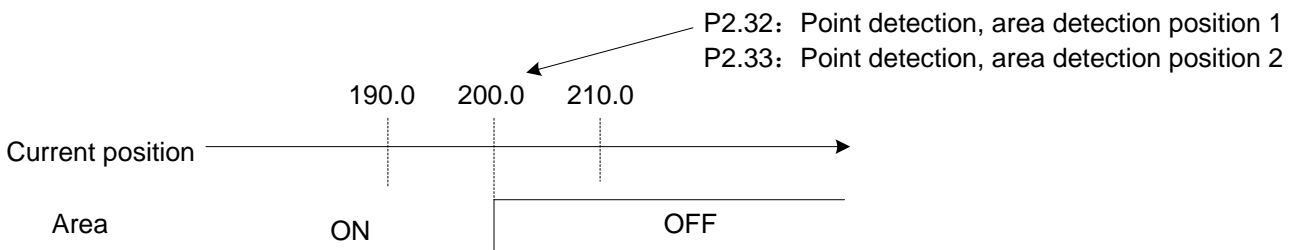

-Limiter detection: (Reference value 19)

With this signal, the limiter function availability can be checked.

This function becomes enabled after homing or position preset.

The limiter function is enabled in the position control mode, and not enabled in the interrupt positioning operation.

The limiter function always stops travels at the detection position even if a position command with the value exceeding the parameter is given, never allowing the travel to exceed the limiter detection position.

The deceleration time in stopping follows the parameters and the positioning data settings.(However, travels are stopped in rapid deceleration during pulse operation.)

After stopped at the limiter detection position, the limiter detection signal is output in the same condition as the In-position signal output.

To return from the limiter detection condition, shift the current position by giving a command in the opposite direction from the detection direction.

The limiter detection signal will turn off, enabling travels in both directions.

-OT detection: (Reference value 20)

The OT detection ("20") is issued while the +OT (7) or -OT (8) EIn signal terminal remains turned off.

In addition, OT detection ("20") is turned on if the current position reaches the reference value of the software OT detection position.

A + OT signal is detected during servomotor travel in the positive direction; while a - OT signal is detected during travel in the negative direction.

The + OT (or - OT) is mechanical position detection, while software OT is position detection of the servo motor drive.

Software OT to reverse the homing motion shall not be applied.

-Cycle end detection: (Reference value 21)

This signal is turned on after the cycle end position is reached if the cycle end is assigned to the positioning data. P2.41 (sequential start selection) must be set at "1" (enable). Change P2.40 (internal positioning data selection) to "1" (enable).

Starting at the positioning data at an arbitrary address, execute positioning data with merely the start positioning signal sequentially until positioning data including the "CEND" status is reached.

Follow the procedure below to execute sequential start.

- (1) Designate the first positioning data number and issue the start positioning signal to start the positioning motion.
- (2) Turn all positioning data addresses off and issue the start positioning signal. The motion starts with the next positioning data.
- (3) Step (2) is repeated until the positioning data including "CEND" is reached
- (4) After positioning motions are completed up to the positioning data including "CEND," the cycle end detection signal is turned on at the same timing as the in-position signal.
- (5) You can supply the start positioning signal with all addresses turned off to repeat the above steps (1) through (4).

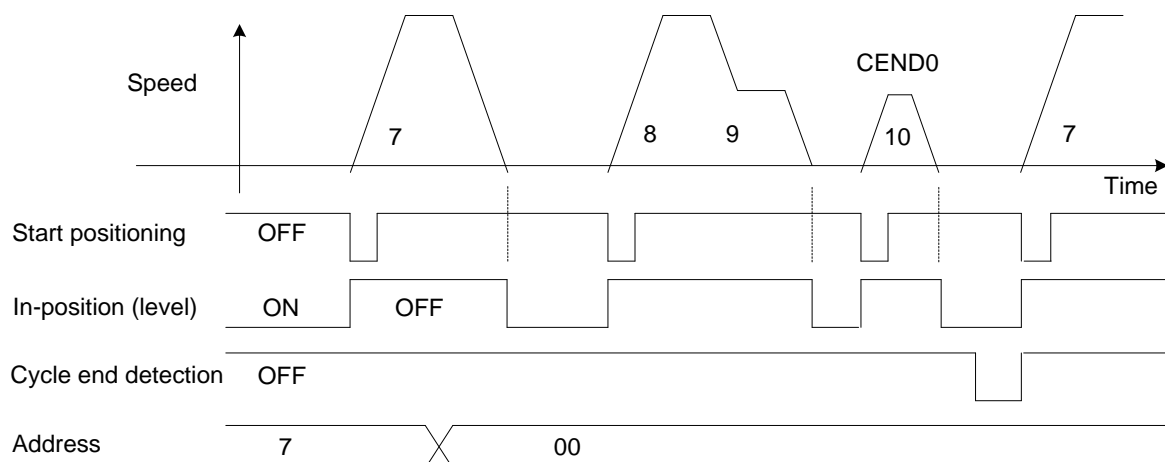

The cycle end detection signal is not output if sequential start cannot be executed.

- If the servo-on signal is turned off.
- If the pulse ratio is enabled or a homing cycle is executed during sequential operation.
- If +OT or -OT is detected or if software OT is detected.

Neither positioning cancel nor pause gives effects on cycle end detection.

When positioning data number 15 is reached during sequential operation, the cycle end process is executed.

If data continuation designation is included in positioning data, operation starts at the next data having no data continuation designation.

·Homing completion: (Reference value 22)

This signal is turned on after the homing motion is finished.

It remains turned on if the feedback position is within P2.17 (home position detection range) around P2.16 (home position after homing completion).

The signal is always turned on after homing if P2.17 is "0" or the maximum value.

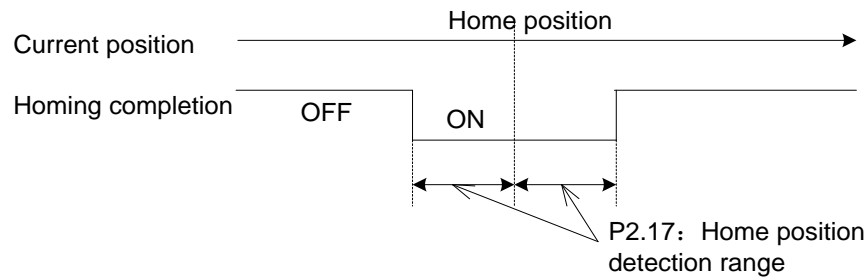

The home position is the stopping point after a homing motion is finished, or a position at which position preset is executed. It does not mean the "0" position.

·Zero deviation: (Reference value 23)

The signal is turned on if the deviation (deviation amount) retained in the servo motor drive becomes within the reference value under position control.

The signal is turned on if the difference (deviation amount) between the command position and feedback position is within the reference value of P1.32 (zero deviation width/in-position range).

The signal status is retained in control modes other than position control mode (such as torque control mode).

Position deviation will not be generated despite the reference value of P1.32.

·Zero speed [NZERO]: (Reference value 24)

The signal is turned on if the servomotor rotation speed is within the reference value of P1.30 (zero speed range).

The signal can be used as a motor stopping condition signal.

·Speed coincidence [NARV]: (Reference value 25)

The signal is turned on if the servomotor rotation speed is within the reference value of P1.29 (speed coincidence range).

The command speed is the reference values of P1.41 to 47 (manual feed speed 1 to 7) and the speed command voltage supplied to the VREF terminal.

The signal is enabled under speed control and position control (interrupt positioning) and in the homing cycle. It is turned off under torque control.

During Manual operation, the signal is not output under the following conditions.

- If the [FWD] or [REV] signal is turned off.
- If the speed does not reach due to P1.25 (max. rotation speed (for position and speed control)).
- If the deceleration time is too long to reach the command speed.

·Torque limit detection: (Reference value 26)

The signal remains turned on while the output torque of the servo motor is at the torque limit value.

The torque limit value can be changed according to conditions. For details, refer to "Torque limit 0,1."

The torque limit detection (26) output is enabled in all control modes.

·Overload warning detection: (Reference value 27)

The signal is turned on if the servomotor load factor is at the reference value.

A warning can be issued before the servomotor is suddenly stopped due to an overload alarm or similar.

The signal is turned on if the load factor of the servo motor reaches the overload warning level of P2.70 (overload warning value).

The signal is automatically turned off if the factor falls below the overload warning level. (There is no way to reset with EIn signal.)

The signal can be issued before the servo motor drive trips due to an overload alarm.

·Servo control ready [S-RDY]: (Reference value 28)

Use the signal to check that the servo motor drive and servo motor operate correctly.

The servo control ready signal remains turned on while the conditions listed in the table below are satisfied.

Signal division	Signal name	Function No.	Signal status
EI input	Forced stop [EMG]	10	ON
	Free-run [BX]	54	OFF
EOUT output	Alarm detection (Normally open contact)	16	OFF
The internal CPU operates correctly.		-	
The R, S, T terminals are turned on.		-	

·Edit permission response: (Reference value 29)

After the edit permission assigned to a EIn input signal is on, under some conditions, the "edit permission response command" is turned on. The conditions are listed in the table below.

Edit permission	P2.74	Parameter change operation	Edit permission response
Not assigned	0: Write enable	Possible	ON
OFF	0: Write enable	Impossible	OFF
ON	0: Write enable	Possible	ON
Not assigned	1: Write protect	Impossible	OFF
OFF	1: Write protect	Impossible	OFF
ON	1: Write protect	Impossible	OFF

·Data error: (Reference value 30)

The signal is turned on if the address and data are incorrect (drifting beyond the specification limit) when performing teaching.

·Address error: (Reference value 31)

The signal is turned on when deviation from the positioning data number range and speed data range (at start) is detected.

The signal is turned on if the start positioning is turned on while AD3 through AD0 are turned off with P2.41 (sequential start selection) being "0" (disable).

Start operation with a correct positioning data number to turn the signal off.

·Alarm code 0: (Reference value 32)

·Alarm code 1: (Reference value 33)

·Alarm code 2: (Reference value 34)

·Alarm code 3: (Reference value 35)

·Alarm code 4: (Reference value 36)

Upon alarm, signal to output alarm details into code.

When an alarm occurs, the detected alarm detail can be specified by checking the signal of the alarm code 0 to 4 assigned to EOUT output signals.

·List of alarm detail and code:

Alarm detail	ALM4	ALM3	ALM2	ALM1	ALM0	Code	Indication	Order
No alarm (normal operation)						00H	nonE	-
Overload 1					1	01H	oL1	15
Overload 2					1	01H	oL2	16
Servo motor drive overheat				1	1	03H	AH	23
Regenerative Transistor Error			1	0	0	04H	rH3	21
Deviation Overflow			1	0	1	05H	oF	22
Overcurrent 1			1	1	0	06H	oC1	1
Overcurrent 2			1	1	0	06H	oC2	2
Overspeed			1	1	1	07H	oS	3
Overvoltage		1	0	0	0	08H	Hv	5
Main Power Undervoltage		1	0	0	1	09H	LvP	18
Encoder error 1		1	0	1	0	0AH	Et1	6
Encoder error 2		1	0	1	0	0AH	Et2	7
Circuit error		1	1	0	0	0CH	cT	8
Memory error		1	1	0	1	0DH	DE	9
Encoder Communication Error	1	0	0	0	0	10H	Ec	13
EI Error	1	0	0	1	1	13H	CtE	14

If there are multiply alarms output at the same time, the servo motor drive display according to the order showing in above table.

1 = ON, 0 = OFF .

Indication indicates characters displayed on the servo motor drive.

·+OT detection: (Reference value 38)

·-OT detection: (Reference value 39)

The state of over-travel (\pm OT) is output.

The corresponding positive or negative OT detection EOUTn is turned on while the +OT or -OT EIn signal terminal remains turned off.

·Home position LS detection: (Reference value 40)

The home position LS detection is turned on while the home position LS EIn signal remains turned on.

·Forced stop detection: (Reference value 41)

Forced stop detection is turned on when the forced stop EIn signal is turned on (relay:open).

For details, refer to "Forced stop."

·MD0: (Reference value 60)

·MD1: (Reference value 61)

·MD2: (Reference value 62)

·MD3: (Reference value 63)

·MD4: (Reference value 64)

·MD5: (Reference value 65)

·MD6: (Reference value 66)

·MD7: (Reference value 67)

The M code of positioning data currently executed is output.

The M code is .hex of 00H~FFH

In case of RS-485 communications, the code can be acquired through in-process positioning data read function.

·Immediate value continuation permission: (Reference value 79)

The immediate value continuation command can be accepted only if this signal is turned on after immediate value operation is started and receive "immediate value continuation command(22)" signal to continue to run with the immediate value.

The signal is turned off after the continuation setting completion signal is turned on. It is turned on again after data continuation is made.

The signal is turned off 50 ms after positioning based on the post-continuation data.

·Immediate value continuation completion: (Reference value 80)

The signal is turned on after continuation of immediate value operation is processed according to an immediate value continuation command(22), and it is turned off after the immediate value continuation command(22) is turned off.

After immediate value operation is started and positioning is completed, the positioning motion continues according to new target position (speed) data.

The positioning motion continues even if deceleration is already started with immediate value operation data.

·Immediate value change completion: (Reference value 81)

The signal is turned on when the changing process is executed according to an immediate value change signal, and it is turned off after the immediate value change is turned off.

While the in-position signal is turned off after immediate value operation is started, the target position and target speed can be changed at an arbitrary timing.

·Command positioning completion: (Reference value 82)

The signal is turned on after the command value inside the servo motor drive is completed.

The signal undergoes ON-to-OFF transition at the start of operation and OFF-to-ON transition upon elimination of the internal command during manual feed, positioning, homing or interrupt positioning.

When continuation of operation is disabled due to alarm detection, emergency stop detection or OT detection, this signal is immediately turned on.

·Timing chart

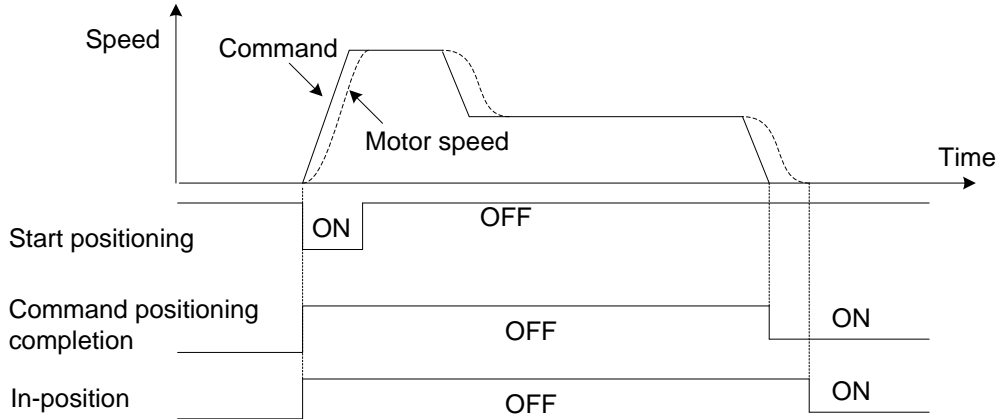

The condition for the next start signal is activation of the command positioning completion signal. Refer to the timing chart below. (Example: Automatic operation continuation)

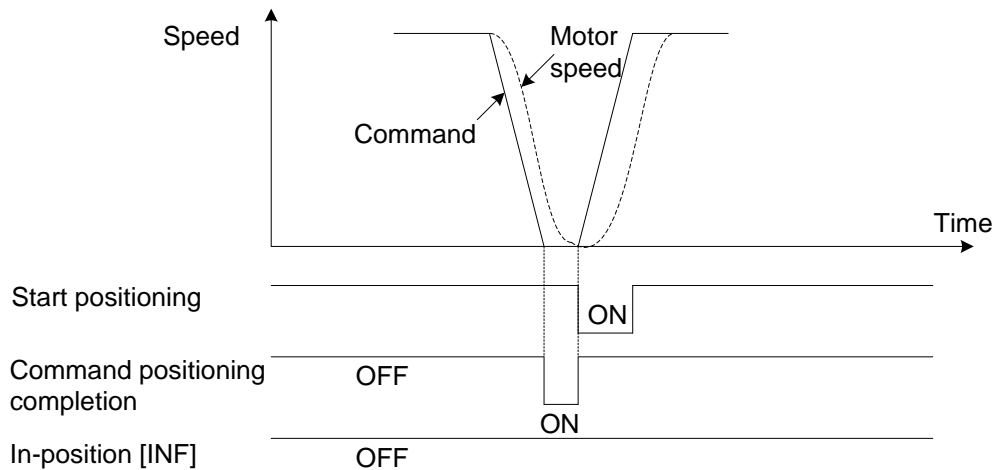

·Range 1 of position: (Reference value 83)

·Range 2 of position: (Reference value 84)

This signal is issued upon detection of the current servomotor position.

This function is enabled after homing or position preset.

The signal can be output at two positions: position range 1 and 2.

Range 1 of position: Enter at P3.92 (range1 of position: setting1), and P3.93 (range1 of position: setting 2).

Range 2 of position: Enter at P3.94 (range2 of position: setting1), and P3.95 (range2 of position: setting 2).

(1) Setting value of P3.92 < Setting value of P3.93

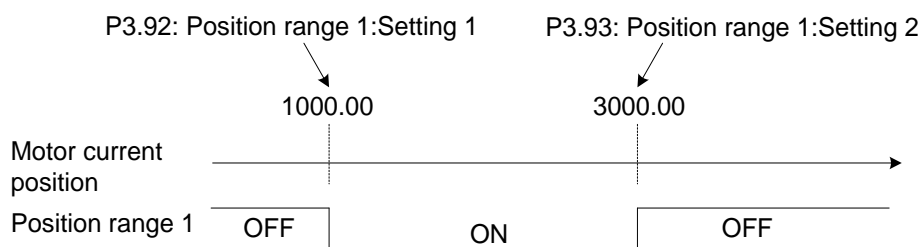

(2) Setting value of P3.92 > Setting value of P3.93

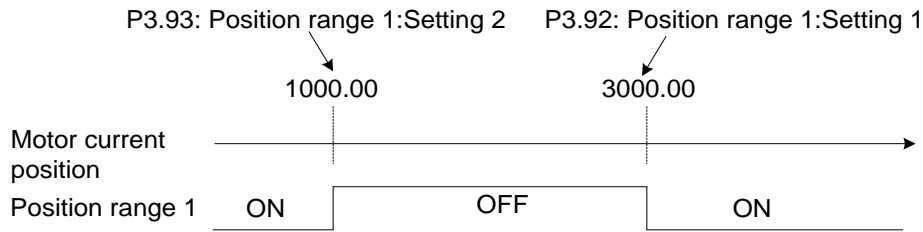

Note: If setting 1 of range 1 of position (P3.92) is the same as setting 2 of range 1 of position (P3.93), range 1 of position is always turned off. The same is true for range 2 of position.

-Interrupt positioning detection: (Reference value 85)

This signal outputs the interrupt positioning motion mode status.

The signal turns on during interrupt positioning motion, and turns off with any of the following conditions:

- ① When the interrupt input enabling signal is turned off after the positioning motion completion.

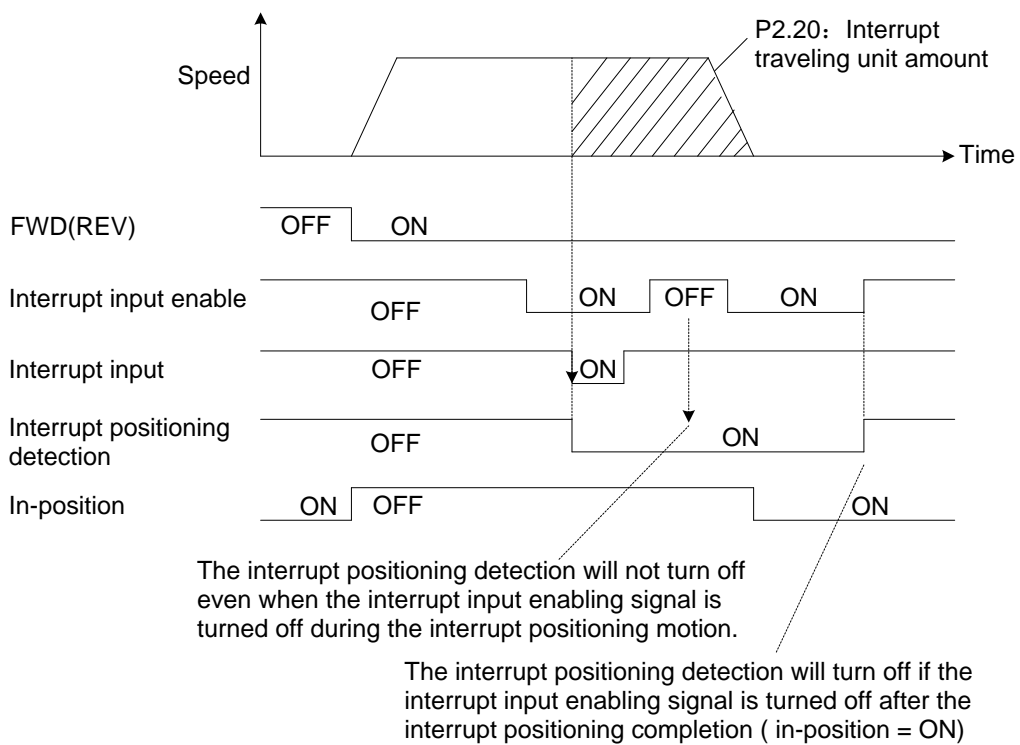

- ② When the next start signal (FWD, REV, START, or ORG) is turned on.

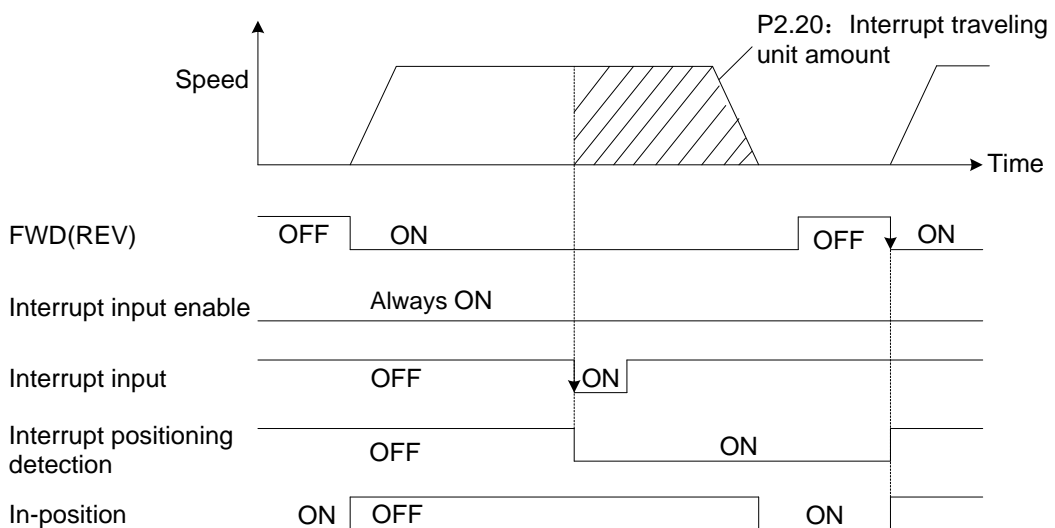

③When the positioning cancel signal is turned on during interrupt positioning motion.

④When changed to other than the position control servo-on mode from the interrupt positioning mode.

Example) EMG: emergency stop by turning to OFF, alarm occurrence, changed to speed control, etc.

·EI20~24 signal status : (Setting value 91 to 95)

The signals set to EI 20 to 24 can be output through EOUT signals 1 to 3 of the hardware.

The ON/OFF status of the EI signal is output as a through signal to the EOUT signal regardless of the function allocation of the corresponding EI signal.

*P3.90	Servo motor model setting	Default value	00
	Setting range	00: No setting 01: SCH060201C-H 50: SCH060201C-T 02: SCH060401C-H 51: SCH060401C-T 05: SCH080751C-H 52: SCH080751C-T 05: SCH080731B-H 13: SCH080102E-H	18: SCH110122C-H 18: SCH110152C-H 17: SCH110122B-H 22: SCH110182C-H 13: SCH130102E-H 18: SCH130132E-H 18: SCH130152E-H 11: SCH130102A-H 17: SCH130152H-H

 Specify according to the servo motor connected.

P3.92	Range 1 of position: Setting 1	Default value	0
P3.93	Range 1 of position: Setting 2	Default value	0
P3.94	Range 2 of position: Setting 1	Default value	0
P3.95	Range 2 of position: Setting 2	Default value	0
	Setting range	-2000000000 to 2000000000 [Units]	

 The current servo motor position is detected.

Assign "Position range1 (83)" function to the EOUTn terminal.

If the setting of range 1 of position - setting 1 (P3.92) is smaller than the setting of range 1 of position - setting 2 (P3.93) and the position specified for range 1 of position - setting 1 (P3.92) passes during forward motion, the range 1 of position signal undergoes OFF-to-ON transition.

If the position specified for range 1 of position - setting 2 (P3.93) passes, the range 1 of position signal undergoes ON-to-OFF transition.

Regarding "Position range 2 (84)", it also can be corresponded to the parameters P3.94 to 95 as last setting.

This function is enabled after homing completion or position pre-set.

6.7 Application Function Parameters (P4.01~99)

P4.20	Position deviation exceeds timeout value	Default value	0
	Setting range	0~65535[ms]	

This parameter is valid under position control.

When the set position deviation is greater than the deviation value set by P2.69, and when the continuous time exceeds the setting value, it will output the alarm

When the setting value is 0, it will output alarm immediately once the position deviation is greater than the deviation value set by P2.69.

P4.21	Speed out-of control level	Default value	1000
	Setting range	0~6000[rpm]	

This parameter is valid under the speed control and position control.

When the set position deviation is greater than the deviation value set by P2.69, it starts to cumulative the timeout time of the loss speed alarm.

The setting value is 0, the alarm function of the loss speed is invalid.

P4.22	Speed out-of control timeout value	Default value	3000
	Setting range	0~65535[ms]	

This parameter is valid under speed control and position control.

When the cumulative timeout time of the loss speed exceeds this setting value, it will output loss speed alarm (LS).

P4.25	Homing timeout value	Default value	0
	Setting range	0~65535[ms]	

This parameter is valid under the position control.

After starting the homing return, if there is no homing return action within the time of the setting value, it will output the homing return timeout alarm (OGE).

When the setting value is 0, it will not inspect the homing return timeout.

P4.69	Brake release delay time after SON	Default value	0
	Setting range	0.00~9.99[s]	

Please configure the "brake output (function NO.14)" signal on the EOUT output signal.

The set value of this parameter is the delay time of the servo enabled to the brake.

Do not give any rotation command to the servo motor within the delay time.

7.1 Settings for Servo Motor Drive

Set up the parameters of the servo motor drive to perform the Modbus communications.

1.1 Protocol Selection

◆ The parameters with "*" indicate that they are enabled only when power on again after parameter setting.

Parameter	Name	Setting range	Default value
P2.97	Communication protocol selection	0:Reserved 1:Modbus RTU (HL) 2:Modbus RTU(LH) 5:Host computer protocol	1

Set to 1 (Modbus RTU) .

1.2 Station Number/Communication Baud Rate

Parameter	Name	Setting range	Default value
*P2.72	Station number	1~31	1
*P2.73	Communication baud rate (RS485)	0:38400 [bps] 4: 57600 [bps] 1:19200 [bps] 5: 4800 [bps] 2:9600 [bps] 6: 2400 [bps] 3:115200 [bps] 7: 1200 [bps]	0

Set a servo motor drive's station number (slave's station number) and a communication baud rate.

1.3 Character Configuration

Parameter	Name	Setting range	Default value
*P2.93	Selection of parity/stop bit	0:8,E,1 3:8,E,2 1:8,O,1 4:8,O,2 2:8,N,1 5:8,N,2	0

Set existence and logic of a parity and a stop bit length.

1.4 Response Time and Communication Time Over

Parameter	Name	Setting range	Default value
P2.94	Response time	0.00~1.00 [s] (※)	0.00
P2.95	Communication time over	0.00 [s]: No detection 0.01~9.99 [s]	0.00

(※) Actual response time is set to P2.94 setting or {time for 3 characters + servo motor drive's processing time}, whichever is longer.

Set the response time and communication time over parameters if needed.

7.2 Communication Specifications

	Item	Specifications	Remarks
Communication	Electric I/F	RS485	
	Communication speed	38400/19200/9600/115200 [bps]	Set by parameter (P2.73)
	Synchronization method	Asynchronous (UART)	
	Communication method	Semi-duplex communication	
	Transmission format	Master-slave (servo motor drive) = 1:N ($1 \leq N \leq 31$)	Max. 31 units connected simultaneously
	Connection cable	LAN cable (straight) or equivalent	
	Cable length (recommended)	Entire extended length:100 m or less (up to 38400 bps) 40 m or less (115200 bps) Length between stations:20 m or less	
	Terminator treatment	Master side :100[Ω] recommended Slave side : Unnecessary	
	Character configuration	Start bit : 1 bit Data length : 8 bits Parity : Even/Odd/None Stop bit : 1 or 2 bits	Set by parameter (P2.93)
Protocol	Communications protocol	Compliant with Modbus RTU protocol	
	Communications mode	RTU mode	The ASCII mode is not supported.
	Station number	0: Broadcast 1-31: Slave station No.	Set by parameter (P2.72)
	Function code (FC)	1(01h): Read out coil data 3(03h): Read out various data 5(05h): Write in single coil data 8(08h): Maintenance (echo back) 15(0Fh): Write in coil data 16(10h): Write in various data	Responses other than those in the left cell are exceptional responses (improper FC).
	Error check method	CRC-16 method	
	Message length	Variable length	Max. 200 bytes

7.3 Transmission Protocol

7.3.1 Message Types

Communications are configured as the single master and multiple slaves method. The servo motor drive operates as a slave.

The messages sent/received between the master and servo motor drive are classified into the two types below:

- Query: Messages transferred from the master to the servo motor drive
- Response message: Messages transferred from the servo motor drive to the master

Communications are started by a query from the master. Communications are not performed between the servo motor drive.

7.3.2 Message Fields

The data format is as follows for both the query from the master and the response message from the servo motor drive.

Station No.	1byte	<ul style="list-style-type: none"> • 0: Broadcast query to all servo motor drives. (No response message is issued.) • 1-31: Query for each station number. Self station numbers 1-31 are responded in the response messages from the servo motor drive. 	
FC (Function code)	1byte	<ul style="list-style-type: none"> • Master: Specify an FC according to the processing that you wish to execute. • Servo motor drive: Returns the specified FC. (If the servo motor drive has not finished processing successfully, the message is returned with the MSB of the FC set to 1.)--Exceptional response 	
Information	Variable length	<ul style="list-style-type: none"> • Query/response message: Data are set according to the FC. • An exceptional code (1 byte) is returned in the exceptional response from the servo motor drive. 	
CRC check	16bit (2byte)	(L)	<ul style="list-style-type: none"> • Query/response message: CRC-16 is added to the bottom of the frame. • The sender calculates CRC-16 for the data sent, add it to the bottom of the frame, and send the frame.
		(H)	<ul style="list-style-type: none"> • The receiver calculates CRC-16 of the received data. If the calculation results are not equal to the received CRC-16, an error occurs. If an error is detected, no response message is returned.

7.3.3 Function Codes (FC)

The six types of FC below are supported:

Category	FC	Function	Broadcasting
Data manipulation	03h (3)	Read out various data	Disabled
	10h (16)	Write in various data	Enabled
Coil data manipulation	01h (1)	Read out coil data	Disabled
	05h (5)	Write in single coil data	Enabled
	0Fh (15)	Write in coil data	Enabled
Maintenance	08h (8)	Echo back	Disabled

-FC 03h (Readout of various data)

(1) Query from the master

Station No.		1 byte		Slave station number, refer to the parameter P2.72.
FC		1 byte		03h
Information	Address	2 byte	(H)	The specified data address, refer to Section 3.4 Address. SDV3 series servo only supports even addresses.
			(L)	
	No. of registers	2 byte	(H)	2 times the number of data specified, maximum 45*2. SDV3 data is 32-bit data, so the number of records is twice the number.
			(L)	
CRC check		2 byte	(L) (H)	CRC check value calculated according to the previous data.

(2) Response message from the servo drive

Station No.		1 byte		Slave station number, refer to the parameter P2.72.
FC		1 byte		03h
Information	No. of data bytes	1 byte		The number of bytes of data to be read. Since the SDV3 data is all 32 bits, the number of data bytes is 4 times the number of data.
	Data 1	4 byte	(HH)	The returned numbers of data, each occupies 4 bytes, the data is arranged in the order from high byte to low byte by default, and the arrangement order of the data can be adjusted by parameter P2.97. P2.97=1, the order of data arrangement is 1234 (default). P2.97=2, the order of data arrangement is 3412.
			(HL)	
			(LH)	
			(LL)	
	~	~		
Data n	4 byte	(HH)	Example: hexadecimal data 0x12345678, By default, the return data sequence is: 0x12 0x34 0x56 0x78. When adjusting the sequence, the return data sequence is: 0x56 0x78 0x12 0x34.	
		(HL)		
		(LH)		
		(LL)		
CRC check		2 byte	(L) (H)	CRC check value calculated according to the previous data.

(3) Message examples

Query example (Read servo motor feedback position)		
Station No.	01	
FC	03	
Address	10	The feedback location address is 0x1006
	0C	
No. of registers	00	Read 1 data, the number of records is 2
	02	
CRC check	00	
	C8	

Response message example		
Station No.	01	
FC	03	
No. of data bytes	04	1 32-bit data, 4 bytes
Data	00	The feedback position is 259539,
	03	
	F5	The corresponding hexadecimal data is 0x0003F5D3
	D3	
CRC check	0C	
	FE	

-FC 10h (Write of various data)

(1) Query from the master

Station No.	1 byte	Slave station number, refer to the parameter P2.72		
FC	1 byte	10h		
Information	Address	2 byte	(H)	The specified data address, refer to Section 3.4 Address SDV3 series servo driver only supports even addresses
			(L)	
	No. of registers	2 byte	(H)	2 times the number of data specified, the maximum is 9*2 SDV3 data is 32-bit data, so the number of records is twice the number
			(L)	
	No. of data bytes	1 byte	4 times the number of data specified, the maximum is 9*4 SDV3 data is 32-bit data, so the number of data bytes is twice the number	
	Data 1	4 byte	(HH)	Each of the n data to be written occupies 4 bytes. The data is arranged in the order from high byte to low byte by default. The arrangement order of the data can be adjusted by parameter P2.97. P2.97=1, the order of data arrangement is 1234 (default); P2.97=2, the order of data arrangement is 3412. Example: To write hexadecimal data 0x12345678, By default, the write data sequence is: 0x12 0x34 0x56 0x78 When adjusting the sequence, the write data sequence is: 0x56 0x78 0x12 0x34
(HL)				
(LH)				
(LL)				
~	~			
Data n	4 byte	(HH)		
		(HL)		
		(LH)		
		(LL)		
CRC check	2 byte	(L)	CRC check value calculated according to the previous data	
		(H)		

(2) Response message from the servo drive

Station No.	1 byte	Slave station number, refer to the parameter P2.72		
FC	1 byte	10h		
Information	Address	2 byte	(H)	The specified data address, refer to Section 3.4 Address SDV3 series servo only supports even addresses
			(L)	
	No. of registers	2 byte	(H)	2 times the number of data actually written SDV3 data is 32-bit data, so the number of records is twice the number
			(L)	
CRC check	2 byte	(L)	CRC check value calculated according to the previous data	
		(H)		

(3) Message examples

Query example (set parameters P1.06=123456)		
Station No.	01	
FC	10	

Response message example		
Station No.	01	
FC	10	

Query example (set parameters P1.06=123456)		
Address	40	Parameter P1.06 address is 0x400C
	0C	
No. of registers	00	Write 1 data, the number of records is 2
	02	
No. of data bytes	04	1 data, 4 bytes
Data	00	Write data as 123456 Converted to hexadecimal: 0x0001E240
	01	
	E2	
	40	
CRC check	DA	
	A9	

Response message example		
Address	40	Address of write data 0x400C
	0C	
No. of registers	00	Actually write 1 data, so the number of records is 2
	02	
CRC check	94	
	0B	

-FC 01h (Read out coil data)

(1) Query from the master

Station No.	1 byte	Slave station number, refer to the parameter P2.72		
FC	1 byte	01h		
Information	Address	2 byte	(H)	The specified bit data address, refer to Section 3.4 Address
			(L)	
Information	No. of coil data	2 byte	(H)	The number of specified bit data, the maximum is 16
			(L)	
CRC check	2 byte	(L)	CRC check value calculated according to the previous data	
		(H)		

(2) Response message form the servo drive

Station No.	1 byte	Slave station number, refer to the parameter P2.72	
FC	1 byte	01h	
Information	No. of data bytes	1 byte	The number of bytes of bit data read, every 8 bits of data occupies 1 byte, less than 8 bits of data is counted as 1 byte
	Data 1	1 byte(8 bits)	Bit data expressed in hexadecimal Starting from the data with the smallest address, configure in LSB order.
	~	~	
	Data n	1 byte(8 bits)	When the corresponding bit is 1, it means ON, and when it is 0, it means OFF. The remaining bits are all fixed to 0.
CRC check	2 byte	(L)	CRC check value calculated according to the previous data
		(H)	

(3) Message examples

Query example (Query the 10 bits of data starting from EOUT6)		
Station No.	01	
FC	01	
Address	03	Specify the EOUT6 address as 0x0305
	05	
No. of coil data	00	Read 10 bits of data
	0A	
CRC check	AC	
	48	

Response message example		
Station No.	01	
FC	01	
No. of data bytes	02	10 data, 2 bytes
Data 1	A5	The meaning of the data is shown in the table below
Data 2	02	
CRC check	43	
	6D	

The meanings of data 1 and data 2 of the servo response are as follows:

Data 1 0xA5	EOUT13	EOUT12	EOUT11	EOUT10	EOUT9	EOUT8	EOUT7	EOUT6
	ON	OFF	ON	OFF	OFF	ON	OFF	ON
Data 2 0x02	0	0	0	0	0	0	EOUT15	EOUT14
							ON	OFF

·FC 05h (Write in single coil data)

(1) Query from the master

Station No.		1 byte		Slave station number, refer to the parameter P2.72
FC		1 byte		05h
Information	Address	2 byte	(H)	The specified bit data address, refer to Section 3.4 Address
			(L)	
	No. of coil data	2 byte	(H)	Write OFF as 0x0000
			(L)	Write ON as 0xFF00
CRC check		2 byte	(L)	CRC check value calculated according to the previous data
			(H)	

(2) Response message form the servo drive

Station No.		1 byte		Slave station number, refer to the parameter P2.72
FC		1 byte		05h
Information	Address	2 byte	(H)	Bit data address to be written
			(L)	
	No. of coil data	2 byte	(H)	Bit data written
			(L)	
CRC check		2 byte	(L)	CRC check value calculated according to the previous data
			(H)	

(3) Message examples

Query example (Communication E19 is set to ON)			Response message example		
Station No.	01		Station No.	01	
FC	05		FC	05	
Address	02	Communication E19-bit address is 0x0208	Address	02	The bit address written is 0x0208
	08			08	
No. of coil data	FF	Set to ON, then write 0xFF00	No. of coil data	FF	Write bit data as 0xFF00
	00			00	
CRC check	0C		CRC check	0C	
	40			40	

-FC 0Fh (Write in coil data)

(1) Query from the master

Station No.		1 byte	Slave station number, refer to the parameter P2.72	
FC		1 byte	0Fh	
Information	Address	2 byte	(H)	The specified bit data address, refer to Section 3.4 Address
			(L)	
	No. of coil data	2 byte	(H)	The specified number of bit data, the maximum is 16
			(L)	
	No. of data bytes	1 byte	The number of bit data bytes written, each 8 bit data occupies 1 byte, less than 8 bit data is counted as 1 byte	
	Data 1	1 byte	Bit data expressed in hexadecimal	
~	~	Starting from the data with the smallest address, configure in LSB order.		
Data n	1 byte	When the corresponding bit is 1, it means ON, and when it is 0, it means OFF. The remaining bits are all fixed to 0.		
CRC check		2 byte	(L)	CRC check value calculated according to the previous data
			(H)	

(2) Response message from the servo drive

Station No.		1 byte	Slave station number, refer to the parameter P2.72	
FC		1 byte	0Fh	
Information	Address	2 byte	(H)	Specified bit data address
			(L)	
	No. of coil data	2 byte	(H)	Number of bit data actually written
			(L)	
CRC check		2 byte	(L)	CRC check value calculated according to the previous data
			(H)	

(3) Message examples

Query example (Set the 3 bits of data starting from EI22)		
Station No.	01	
FC	0F	
Address	02	Communication EI22 bit address is 0x0215
	15	
No. of coil data	00	Write 3 bits of data
	03	
No. of data bytes	01	3 bits of data occupies 1 byte
Data 1	06	The meaning is shown in the table below
CRC check	03	
	74	

Response message example		
Station No.	01	
FC	0F	
Address	02	The bit address written is 0x0208
	15	
No. of coil data	00	Write bit data as 0xFF00
	03	
CRC check	05	
	B6	

7.3.4 Address

For the addresses, refer to the table as below.

Note: SDV3 data is 32-bit data, so only even address access is supported, and the number of access data must also be even (except for bit data access).

•Data address

List of data address

Data type	Data name	Address (hex.)	Applicable FC		Format (with a sign)	Setting range (default value)
			03h	10h		
Communication EI/EOUT signal	Communication EI signal	0000	○	○	Lower 16 bit applicable EI9~24 (No)	0~FFFFh(0:OFF all)
	Communication EOUT signal	0100	○	×	Lower 16 bit applicable EOUT6~21 (No)	—
Monitor	Feedback speed	1000	○	×	1h = 1 [r/min] (Yes)	—
	Command speed	1002	○	×	1h = 1 [r/min] (Yes)	—
	Command torque	1004	○	×	1h = 1 [%] (Yes)	—
	Peak torque	1006	○	×	1h = 1 [%] (Yes)	—
	Motor current	1008	○	×	1h = 0.1[A] (No)	—
	Effective torque	100A	○	×	1h = 1 [%] (No)	—
	Feedback position	100C	○	×	1h = 1[Units](Yes)	—
	Command position	100E	○	×	1h = 1[Units](Yes)	—
	Position deviation	1010	○	×	1h = 1 [(※)] (Yes)	—
	Command pulse frequency	1012	○	×	1h = 0.1 [kHz] (No)	—

Data type	Data name	Address (hex.)	Applicable FC		Format (with a sign)	Setting range (default value)
			03h	10h		
Monitor	Feedback cumulative pulses	1014	○	×	1h = 1 [pulse] (Yes)	—
	Cumulative input pulses	1016	○	×	1h = 1 [pulse] (Yes)	—
	LS-Z pulse	1018	○	×	1h = 1 [pulse] (No)	—
	Load inertia ratio	101A	○	×	1h = 0.1[Times](No)	—
	DC link voltage(max.)	101C	○	×	1h = 1 [V] (No)	—
	DC link voltage(min.)	101E	○	×	1h = 1 [V] (No)	—
	VREF input voltage	1020	○	×	1h = 0.01 [V] (Yes)	—
	TREF input voltage	1022	○	×	1h = 0.01 [V] (Yes)	—
	OL thermal value	1024	○	×	1h = 1 [%] (No)	—
Sequence monitor	Hardware EI signal	2000	○	×	Lower 6 bit applicable EI1~6(No)	—
	Hardware EOUT signal	2002	○	×	Lower 5 bit applicable EOUT1~3(No)	—
	Control mode	2100	○	×	Please refer to detail manual	—
	Action mode	2102	○	×		—
	Alarm at present	2200	○	×		—
	Alarm history 1-20	2202~2228	○	×		—
Various command	Comm speed	3000	○	○	1h = 0.01 [rpm] (Yes)	-6000.00~6000.00(0)
	Comm torque	3002	○	○	1h = 1 [%] (Yes)	-300~300(0)
	Anti resonance frequency	3004	○	○	1h = 0.1 [Hz] (No)	0.0, 1.0~300.0(0.0: The vibration suppressing control function is disabled.)
	Workpiece inertia ratio	3006	○	○	1h = 1 [%] (No)	0~80 (0)
Parameter	P1.01~99	4000~40C4	○	○	Refer to the parameter	The parameter is followed.
	P2.01~99	4100~41C4	○	○		
	P3.01~99	4200~42C4	○	○		
	P4.01~99	4300~43C4	○	○		
Immediate value data	Immediate value status	5100	○	○	Please refer to detail manual	—
	Immediate value position	5102	○	○	1h = 1[Units](Yes)	0~±2000000000 (0)
	Immediate value speed	5104	○	○	1h = 0.01 [r/min] (No)	0.01-Max. rotation speed (0.01)

Data type	Data name	Address (hex.)	Applicable FC		Format (with a sign)	Setting range (default value)
			03h	10h		
Immediate value data	Immediate value acceleration time	5106	○	○	1h = 0.1 [ms] (No)	0.0~99999.9 (0.0)
	Immediate value deceleration time	5108	○	○	1h = 0.1 [ms] (No)	0.0~99999.9 (0.0)
Positioning data 1	Positioning status + M code	6000	○	○	Please refer to detail manual	-
	Stop timer	6002	○	○	1h = 0.01 [ms] (※)	0.00~655.35 (0.00)
	Stop position	6004	○	○	1h = 1 [unit] (Yes)	0~±2000000000 (0)
	Rotation speed	6006	○	○	1h = 0.01 [r/min](No)	0.01~Max. rotation speed (0.01)
	Acceleration time	6008	○	○	1h = 0.1 [ms] (No)	0.0~99999.9 (0.0)
	Deceleration time	600A	○	○		
Positioning data 2	Positioning status + M code	600C	○	○	Please refer to detail manual	-
	Stop timer	600E	○	○	1h = 0.01 [ms] (※)	0.00~655.35 (0.00)
	Stop position	6010	○	○	1h = 1 [unit] (Yes)	0~±2000000000 (0)
	Rotation speed	6012	○	○	1h = 0.01 [r/min](No)	0.01~Max. rotation speed (0.01)
	Acceleration time	6014	○	○	1h = 0.1 [ms] (No)	0.0~99999.9 (0.0)
	Deceleration time	6016	○	○		
ゝ	ゝ	ゝ	ゝ	ゝ	ゝ	ゝ
Positioning data 15	Positioning status + M code	60A8	○	○	Please refer to detail manual	-
	Stop timer	60AA	○	○	1h = 0.01 [ms] (※)	0.00~655.35 (0.00)
	Stop position	60AC	○	○	1h = 1 [unit](Yes)	0~±2000000000 (0)
	Rotation speed	60AE	○	○	1h = 0.01 [r/min](No)	0.01~Max. rotation speed (0.01)
	Acceleration time	60B0	○	○	1h = 0.1 [ms](No)	0.0~99999.9 (0.0)
	Deceleration time	60B2	○	○		
Positioning data	Positioning data 1-15	D000~D01 C	○	○	Please refer to detail manual	—

(※) By setting P1.31 (selection of deviation unit), 0 and 1 are defined as unit and pulse, respectively.

(※) Set 0:0.01 [ms]/1:0.001 [ms] according to P2.42 (stop timing decimal point position).

-Coil address

Coil address list

Coil type	Coil name	Address (hex.)	Applicable FC		
			01h	05h	0Fh
Communication EI signal	EI9 Signal	0208	○	○	○
	ゝ	ゝ			
	EI24 Signal	0217			
Communication EOUT signal	EOUT6 Signal	0305	○	×	×
	ゝ	ゝ			
	EOUT21 Signal	0314			
Hardware EI signal	EI1 Signal	0400	○	×	×
	ゝ	ゝ			
	EI5 Signal	0404			
Hardware EOUT signal	EOUT1 Signal	0500	○	×	×
	ゝ	ゝ			
	EOUT3 Signal	0502			

7.3.5 Address Supplementary Description

The 32-bit data structure described in this section is high word first and low word last (P2.97=1). When P2.97 is set to 2, please change the order of high and low word data by yourself.

- EI/EOUT signal

EI/EOUT signals are classified into hardware signals (input/output terminals) and communication signals (Modbus communication) according to their input/output forms. The classifications are as follows.

	Hardware signal	Communications signal
EI signal	EI1~8 (8bit)	EI9~24 (16bit)
EOUT signal	EOUT1~5 (5bit)	EOUT6~21 (16bit)

Through RS485 communication, the EI/EOUT signal can perform the overall operation specified by the data address (FC 03h, 10h), and the operation per bit specified by the bit data address (FC 01h, 05h, 0Fh).

When using the overall operation (FC 03h, 10h), the read/write process is to process the same kind of signals as hexadecimal data.

The signal configuration in the data is shown below. When the corresponding bit is 1, it means ON, and when it is 0, it means OFF.

a) Communication EI signal (EI 9~24)

Data	4 byte	00h							
		00h							
		EI 24	EI 23	EI 22	EI 20	EI 20	EI 19	EI 18	EI 17
		EI 16	EI 15	EI 14	EI 13	EI 12	EI 11	EI 10	EI 9

b) Communication EOUT signal (EOUT 6~21)

Data	4 byte	00h							
		00h							
		EOUT 21	EOUT 20	EOUT 19	EOUT 18	EOUT 17	EOUT 16	EOUT 15	EOUT 14
		EOUT 13	EOUT 12	EOUT 11	EOUT 10	EOUT 9	EOUT 8	EOUT 7	EOUT 6

c) Hardware EI signal (EI1~8)

Data	4 byte	00h							
		00h							
		00h							
		EI 8	EI 7	EI 6	EI 5	EI 4	EI 3	EI 2	EI 1

d) Hardware EOUT signal (EOUT 1~5)

Data	4 byte	00h							
		00h							
		00h							
		0	0	0	EOUT 5	EOUT 4	EOUT 3	EOUT 2	EOUT 1

- Control mode, Action mode, Alarm at present, Alarm history

Each piece of data in the control mode, action mode, alarm at present, and alarm history is the code data of 1 byte.

DATA	4byte	00h
		00h
		00h
		Code

The content of the code varies depending on the data. For the detail, refer to below tables.

Control mode

Code	Control mode
00h	Position control
01h	Speed control
02h	Torque control

Action mode

Code	Action mode
00h	Servo OFF
01h	Servo ON
02h	Zero speed stop
03h	Manual operation (JOG)
04h	Pulse operation
05h	+OT
06h	-OT
07h	In LV (under voltage)
08h	Positioning
09h	Homing
0Ah	Interrupt positioning

Alarms at present and alarm histories

Code	Alarm	Symbol (※)
00h	None	---
01h	Overcurrent 1	oc1
02h	Overcurrent 2	oc2
03h	Overspeed	oS
04h	Control Power Undervoltage	Luc
05h	Overvoltage	Hu
06h	Encoder Error 1	Et1
07h	Encoder Error 2	Et2
08h	Circuit Error	ct
09h	Memory error	dE
0Bh	Motor Combination Error	cE
0Dh	Encoder Communication Error	Ec
0Eh	EI error	ctE
0Fh	Overload 1	oL1

Code	Alarm	Symbol (※)
10h	Overload 2	oL2
12h	Overcurrent 3	oc3
13h	Encoder Matching Exception	Ec2
20h	External Terminal Alarm	EF
21h	Main Power Undervoltage	LuP
24h	Regenerative Transistor Error	rH3
25h	Deviation Overflow	oF
26h	Servo motor drive overheat	AH
28h	Absolute Data Lost 1	dL1
29h	Absolute Data Lost 2	dL2
2Ah	Absolute Data Lost 3	dL3
2Bh	Multi-turn Data Over Flow	AF
2Eh	Homing timeout	oGE
2Fh	Speed out of control	LS

(※) indicates the symbols displaying on the keypad of the servo motor drive.

• Immediate value data

The immediate value status of immediate data is configured as follows:

		Configuration		Format (default value)
Data	4byte	Immediate value status	1byte	Refer to below table
		Immediate value M code	1byte	0~FFh (FFh)
		Not used	2byte	00h fixed

Immediate value status

bit	Item	Description	Default value
5	M code output timing	0: Output during start up 1: Output after positioning completion	0
4	M code selection	0: Disable 1: Enable	0
0	Command method	0:ABS 1:INC	1
Others	Not used	0 fixed	0

- Positioning data

Positioning data are 20 bytes long for each set, organized as follows:

		Configuration		Format, setting range (default value)		
Data	20byte	Positioning status	1byte	Refer to below table		
		M Code	1byte	0~FFh(FFh)		
		Stop timer	2 byte	(H)	1h = 0.01 [ms] (※)	
				(L)	0.00~655.35 (0.00)	
		Stop position	4 byte	(HH)	1h = 1 [Units] 0~±2000000000 (0)	
				(HL)		
				(LH)		
				(LL)		
		Rotation speed	4 byte	(HH)	1h = 0.01 [r/min] 0.01 - Max. rotation speed (0.01)	
				(HL)		
(LH)						
(LL)						
Acceleration time	4 byte	(HH)	1h = 0.1 [ms] 0.0~99999.9 (0.0)			
		(HL)				
		(LH)				
		(LL)				
Deceleration time	4 byte	(HH)	1h = 0.1 [ms] 0.0~99999.9 (0.0)			
		(HL)				
		(LH)				
		(LL)				

(※) By setting P2.42 (stop timer decimal point position), 0 and 1 indicate 0.01 ms and 0.001 ms, respectively.

Positioning status

bit	Item	Description	Default value
5	M code output timing	0: Output during startup 1: Output after positioning completion	0
4	M code Selection	0: Disable 1: Enable	0
2,1	Step mode	0,0: No specification 0,1: Data continuation (CO) 1,0: Cycle end (CEND) 1,1: Setup impossible	0,0
0	Command method	0:ABS 1:INC	1
Others	Not used	0 fixed	0

7.3.6 Exceptional Responses

The servo motor drive returns an exceptional response if it has not succeed the process specified by a query.

The message frame is as follows. This is common to all FC values.

Station No.	1byte	
FC	1byte	
Exceptional code	1byte	
CRC check	16bit	(L)
	(2byte)	(H)

(1) Function code (FC) field

Exceptional responses from slaves are returned as one is set on the MSB of the FC specified by the query.

Query	Exceptional response	Query	Exceptional response
01h	81h	08h	88h
03h	83h	0Fh	8Fh
05h	85h	10h	90h

(2) Exceptional code field

Exceptional responses from slaves are returned as exceptional response which indicates exceptional content with the query.

Exceptional code	Description and sample queries
01h	<p>Incorrect FC (An incorrect FC is specified.)</p> <ul style="list-style-type: none"> An FC other than 01h, 03h, 05h, 08h, 0Fh, and 10h, which are supported, is specified.
02h	<p>Incorrect address (An incorrect address is specified)</p> <p>When FC 03h or 10h is specified</p> <ul style="list-style-type: none"> An address not listed in data addresses list is specified. The address that is listed only for FC 03h in data addresses list is specified for FC 10h. <p>When FC 01h, 05h or 0Fh is specified</p> <ul style="list-style-type: none"> An address not listed in coil data addresses list is specified. The address that is listed only for FC 01h in coil data addresses list is specified for FC 05h or 0Fh.
03h	<p>Incorrect data (An abnormal value is specified in the information field.)</p> <p>When FC 03h or 10h is specified</p> <ul style="list-style-type: none"> The following value is specified as the no. of registers: zero, odd number, or a value exceeding the maximum value. A value different from the no.of registers is specified to the no. of data bytes. A value out of range is specified to a write data. <p>When FC 01h, 05h or 0Fh is specified</p> <ul style="list-style-type: none"> The following value is specified as the no. of coil data: zero, or a value exceeding the maximum value. A value different from the no. of coil data is specified to the no. of data bytes. A value not specified as ON/OFF values is specified to a coil data in FC 05h.

8 Script Function

The SDV3 Series Servo Supports script feature, it can control the servo motor flexibly via this function, add some custom control functions, or to save the controller in some simple occasions, in order to reduce the costs. The script runs through the SAVCHSOFT_SRV host machine's script editor, the programming language used is Lua, please refer to "SDV3 script function descriptions".

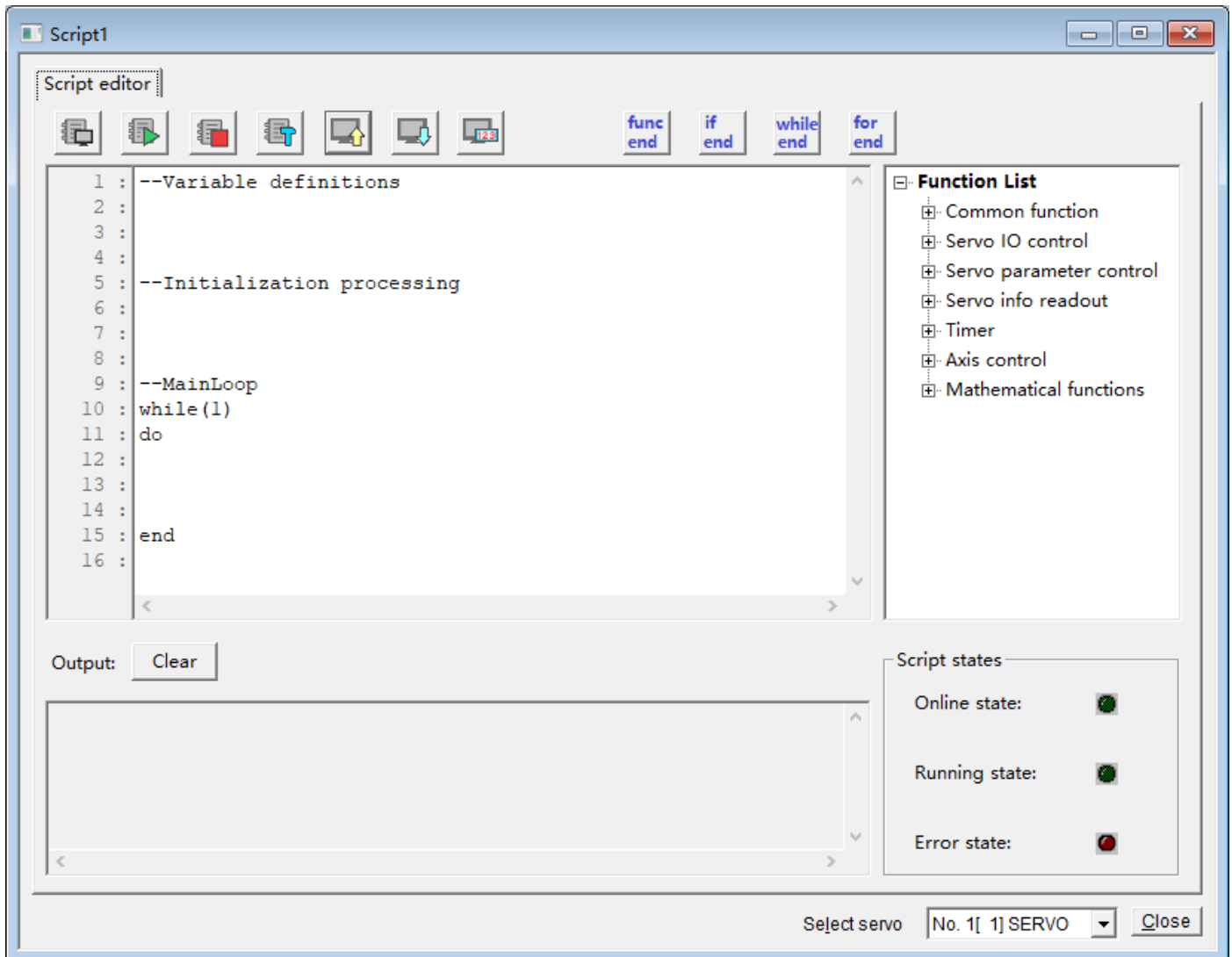

9.1 Inspection

- Periodic inspection items

The periodic inspection items are shown below.

Device	Description of inspection
Servo motor	<ul style="list-style-type: none">• There is no deviation in the linkage between the servo motor shaft and mechanical system.• The servo motor is free from direct splashes of water, vapor or oil.• The servo motor itself does not vibrate excessively.
Servo motor drive	<ul style="list-style-type: none">• Screws of the terminal block and mounting sections are not loose.• Connectors are inserted correctly.• There is no massive dust on the servo amplifier.• There is no malodor, damage, breakage or faults in appearance.

Note: Before checking cables of the servo motor and servo motor drive, turn the power off and wait at least five minutes and check that the charge LED is unlit.

9.2 Status Display

9.2.1 Alarm Display List

In case of alarm, the servo motor drive will indicate alarm code on the key pad.

Refer to below table for the detail. Be sure to check the alarm code to clarify the cause of the alarm.

Display	Name	Type
oc1	Overcurrent1	Major
oc2	Overcurrent2	
oc3	Overcurrent 3	
oS	Overspeed	
LuC	Control Power Undervoltage	
Hu	Overvoltage	
Et1	Encoder Trouble 1	
Et2	Encoder Trouble 2	
ct	Circuit Trouble	
dE	Memory Error	
Ec	Encoder Communication Error	
Ec2	Encoder matching exception	
cE	Motor Combination Error	
ctE	EI(Control signal) Error	
oL1	Overload 1	

Display	Name	Type
oL2	Overload 2	
LuP	Main Power Undervoltage	Minor
rH3	Regenerative Transistor Error	
oF	Deviation Overflow	
AH	Servo motor drive Overheat	
dL1	Absolute Data Lost 1	
dL2	Absolute Data Lost 2	
dL3	Absolute Data Lost 3	
AF	Multi-turn Data Over Flow	
EF	External terminal alarm	
LS	Speed out of control	
oGE	Homing timeout	

To reset the alarm, perform one of the following methods.

- Turn the alarm reset (RST: EI input signal) on temporarily and then turn it off.
- From the keypad, select the additional function mode [AF-05] and execute the alarm reset.
- On the alarm screen, press and hold the [^] and [v] keys of the keypad simultaneously for at least one second.
- After the alarm reset, the data specified with parameter " P2.77 (initial display of the keypad)" is displayed.

Alarm reset

Some alarms cannot be cleared through alarm resetting. To remove the alarm that is not cleared through alarm resetting, remove the cause of the alarm following the method described in "8.3 Troubleshooting Method" after (or before) the power is turned off, and then reset the status by turning the power again.

Alarms cleared through alarm resetting

Display	Name
oc1	Overcurrent 1
oc2	Overcurrent 2
oc3	Overcurrent 3
oS	Overspeed
Hu	Overvoltage
Ec	Encoder communication error
oL1	Overload 1
oL2	Overload 2

Display	Name
LuP	Main Power Undervoltage
Luc	Control Power Undervoltage
oF	Deviation overflow
AH	Servo motor drive overheat
EF	External terminal alarm
LS	Speed out or control
oGE	Homing timeout

Alarms not cleared through alarm resetting

Display	Name
Et1	Encoder trouble 1
Et2	Encoder trouble 2
ct	Circuit trouble
dE	Memory error
ctE	EI Error

rH3	Regenerative Transistor Error
dL1	Absolute Data Lost 1
dL2	Absolute Data Lost 2
dL3	Absolute Data Lost 3
AF	Multi-turn Data Over Flow
Ec2	Encoder matching exception

※dL1~dL3, AF can be released by position preset

The steps of alarm reset through the additional function mode from the keypad is shown below.

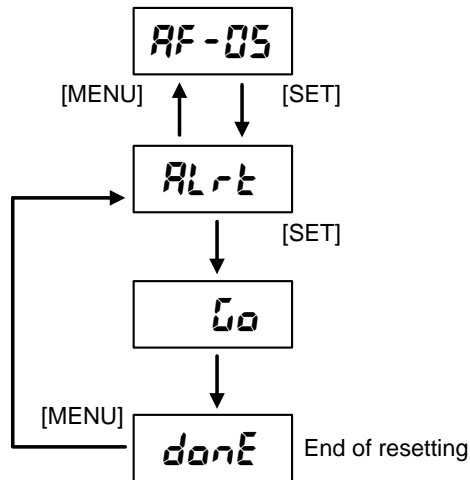

9.3 Troubleshooting Method

(1) Overcurrent

【Display】

oc1

oc2

oc3

【Description of detected alarm】

The output current of the servo motor drive exceeds the rated value.

OC1: Direct detection by internal transistor of servo motor drive.

OC2: Indirect detection with software of servo motor drive.

OC3: Direct detection by internal transistor of servo motor drive.

【Causes and Solutions】

Causes	Solutions
Wrong servo motor output wiring	Correct the wiring of power cables (U, V and W).
Short circuit or grounding fault in Servo motor output wiring	Check cables visually or through continuity check and replace the defective cable.
Servo motor insulation fault	Measure the insulation resistance. (Several MΩ or over to ground)
Failure of servomotor	Measure the resistance across cables. (Several Ω between cables)
Incorrect resistance of regenerative resistor	Replace with the regenerative resistor within the rating.
Current imbalance caused by an encoder fault	Replace the servo motor

Causes	Solutions
Unconnected grounding cable	Connect the grounding cable

When the oc alarm occurs, do not power on frequently, and power on after troubleshooting, otherwise the drive may be damaged.

(2) Overspeed

【Display】



【Description of detected alarm】

The rotation speed of the servomotor exceeds 1.1 times the maximum speed.

【Causes and Solutions】

Causes	Solutions
Wrong servomotor output wiring	Correct the wiring of power cables (U, V and W).
The rotation speed of the Servo motor overshoots.	Check the speed waveform during acceleration (see the figure below) and take the following countermeasures. <ul style="list-style-type: none"> • Increase P1.37 (acceleration time). • Increase P1.52 (S-curve time constant). • Increase P1.15 (auto tuning gain 1).

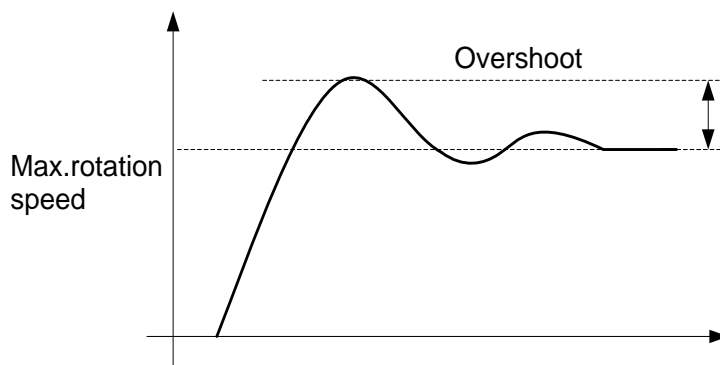

(3) Overvoltage

【Display】



【Description of detected alarm】

The DC voltage inside the servo motor drive exceeds the upper limit.

【Causes and Solutions】

Causes	Solutions
The source voltage is too high (immediately after power-on).	<ul style="list-style-type: none"> • Check if the source voltage is within the specification limits. • Insert a reactor if there is a power factor improvement capacitor.
Unconnected external regenerative resistor or wrong wiring	<ul style="list-style-type: none"> • Connect the external regenerative resistor. • Correct the wiring of the external regenerative resistor.
Broken regenerative transistor	Replace the servo motor drive

The internal DC voltage can be checked in the monitor mode of the keypad.

[dP-15]: Internal DC link voltage (max. value), if approximately over 420 V, overvoltage is detected

(4) Encoder Trouble

【Display】



【Description of detected alarm】

There is a fault in the encoder built in the servo motor.

1. Et1: Single revolution position detection fault of encoder.
2. Et2: Encoder memory data reading fault.

【Causes and Solutions】

Causes	Solutions
Fault in data sent from encoder	Use shielded cables to eliminate noise effects.
Failure of encoder	Replace the servo motor.

(5) Circuit Trouble

【Display】

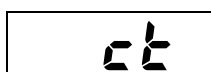

【Description of detected alarm】

There is a fault in the source control power voltage inside the servo motor drive. There may be a failure in the internal circuit.

【Causes and Solutions】

Causes	Solutions
Failure of servo motor drive	Turn the power off then on again. If restoration is not obtained, replace the servo motor drive.

(6) Memory Error

【Display】



【Description of detected alarm】

The parameter data stored in the servo motor drive is damaged.

【Causes and Solutions】

Causes	Solutions
Failure of stored data	<ul style="list-style-type: none">• Initialize parameters and positioning data.• If restoration is not obtained with the actions above, replace the servo motor drive.
The parameter overwriting frequency has exceeded 100,000 cycles.	Replace the servo amplifier. (Store the parameters which are overwritten frequently to P2.80 to 85, parameter in RAM 1 to 6.)

(7) Encoder communication error

【Display】

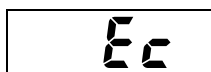

【Description of detected alarm】

Communications with the internal encoder of the servo motor fails.

【Causes and Solutions】

Causes	Solutions
Error in encoder serial communications	<ul style="list-style-type: none"> • Check cables visually and through continuity check and correct faults. • Check for the broken wire in the encoder cable and correct if broken. • Insert ferrite cores.
Broken wire or poor contact	

The servo motor drive and encoder communicate through high speed serial communications.

The encoder signal has a voltage amplitude of about 5 V. Do not route the encoder cable in a strong magnetic or electric field. Route the encoder cable separately from the main body of the servo motor drive, inverter, electromagnetic contactor or similar (reserve at least 100 mm).

(8) EI Error

【Display】

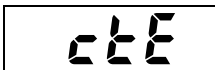

【Description of detected alarm】

There is duplication in allocation of EI input terminals of the servo motor drive.

【Causes and Solutions】

Causes	Solutions
The same input signal is allocated to two or more terminals.	Do not specify the same number among EI signal settings.

(9) Overload

【Display】



【Description of detected alarm】

- OL1: Alarm that detects failures such as a locked shaft instantaneously. (3s/300%)
- OL2: The effective torque exceeds the allowable limit of the servo motor. (Detection at electronic thermal relay built in servo motor drive)(about 200s/200%)



【Causes and Solutions】

Causes	Solutions
The servo motor fails to rotate mechanically.	<ul style="list-style-type: none"> • Check the wiring of power cables (U, V and W) and correct faults. • Check if the brake is active.
The mechanical system is too heavy against the servo motor capacity.	<ul style="list-style-type: none"> • Examine the servo motor capacity, based on the load factor. • If the rotation speed can be reduced, add a reduction gear. • Apply the brake to retain a stopped elevator.
The acceleration/deceleration frequency and operation frequency are too high.	Increase the cycle time and decrease the operation frequency.
Servo motor drive is damaged.	Replace the servo motor drive

If an OL2 alarm is caused but no damaged servo motor drive or incorrect wiring is found, the Servo motor capacity must be examined.

(10) Main Power Undervoltage

【Display】

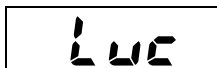
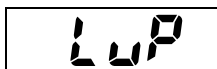

【Description of detected alarm】

The power supplied to the servo motor drive falls below the minimum specification voltage limit.

【Causes and Solutions】

Causes	Solutions
The source voltage drops due to momentary power failure or similar.	<ul style="list-style-type: none"> • Check the power supply environment whether momentary power failure is generated or not, and improve the power supply environment. • Check and improve the power supply capacity and transformer capacity.

If the power supply environment is adverse, P2.67 (alarm detection at undervoltage) can be applied to ignore undervoltage detection. In this case, operation can be continued with the setting of P2.66 (flying start at speed control) in the event of momentary power failure. Undervoltage detection is set at about 200 V by the DC voltage in the servo motor drive.

(11) Regenerative Transistor Error

【Display】

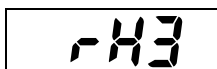

【Description of detected alarm】

The regeneration handling transistor built in the servo motor drive is damaged.

【Causes and Solutions】

Causes	Solutions
The regenerative transistor is short circuited or damaged.	Turn the power off then on again. If the alarm persists, replace the servo motor drive.

Note: If the regenerative transistor is short circuited or damaged, fire may be caused. If the regenerative transistor fault alarm signal is output, turn the power off immediately.

(12) Deviation Overflow

【Display】

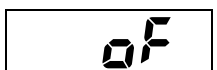

【Description of detected alarm】

A position deviation amount equivalent to servo motor revolutions specified in P2.69 (deviation detection overflow value) is accumulated inside the servo motor drive.

【Causes and Solutions】

Causes	Solutions
Wrong connection of power cables (The alarm is alerted immediately when servo-on is turned on.)	Check and correct the wiring of power cables (U, V and W).
The servo motor fails to rotate mechanically.	Check if the brake is applied.

Causes	Solutions
Low output torque	Increase P1.27, 28 (torque limit).
The deviation detection width is small.	Increase P2.69 (deviation detection overflow value).
The servo motor drive is in the P control mode.	Turn off the P motion signal.
Low gain	Perform gain adjustment.
Acceleration/deceleration of pulse frequency is too acute.	Increase the acceleration/deceleration time.

(13) Servo motor drive overheat

【Display】



【Description of detected alarm】

The temperature of the servo motor drive has exceeded the allowable limit.

【Causes and Solutions】

Causes	Solutions
The ambient temperature exceeds 55°C.	Reduce the ambient temperature to 55°C or lower. (40°C or lower temperatures are recommended for regular operation.)
	Move heat generating bodies near the servo motor drive as far away as possible.

(14) ABS Data loss

【Display】



【Description of detected alarm】

- Encoder absolute value data loss
- dL1=The battery is low and the encoder cable is broken.
- dL2 = multi-turn data error inside the encoder
- dL3=Re-energization check when an ET alarm occurs

【Causes and Solutions】

Causes	Solutions
dL1 Alarm occurs	Confirm and repair the disconnection status of the encoder cable. Replacement battery
dL2 Alarm occurs	If the position preset cannot be released, replace the servo motor.
dL3 Alarm occurs	Can release dL3 with position preset, but residual ET alarm. If the ET alarm cannot be cancelled, replace the servo motor.

(15) Multi-circle overflow

【Display】

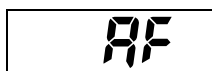

【Description of detected alarm】

The output shaft of the servo motor has rotated -32767~+32766

【Causes and Solutions】

Causes	Solutions
Large amount of servo motor rotation	Confirm the amount of rotation of the servo motor Confirm target location

(16) Abnormal motor combination

【Display】

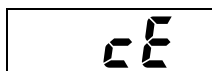

【Description of detected alarm】

The encoder of the servo motor does not match the selected servo operating mode

Motor ID setting error

【Causes and Solutions】

Causes	Solutions
When the value of parameter P1.02 is not 0, the value of parameter P2.99 (encoder selection) is not 5	When using the absolute value mode, select the encoder as the encoder with battery (P2.99=5)
Parameter P3.90 sets values other than those described in the manual.	Please follow the instructions to correctly set the value of parameter P3.90.

(17) Encoder matching exception

【Display】

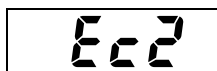

【Description of detected alarm】

The currently connected encoder does not match the encoder set by the drive.

【Causes and Solutions】

Causes	Solutions
The set value of the parameter P2.99 does not match the connected encoder.	Set the correct parameter value according to the bits of encoders.

(18) External terminal alarm

【Display】

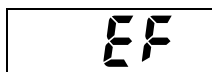

【Description of detected alarm】

The EI terminal of the external terminal alarm function is set to ON.

【Causes and Solutions】

Causes	Solutions
The EI terminal of the external terminal alarm function is set to ON.	If you do not need this alarm function, set the parameter corresponding to the EI terminal to 0

(19) Speed out of control

【Display】

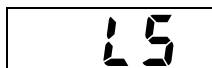

【Description of detected alarm】

The deviation between the command speed and the feedback speed is too large.

【Causes and Solutions】

Causes	Solutions
Wrong connection of power cables	Check and correct the wiring of power cables (U, V and W)
The servo motor fails to rotate mechanically	Check if the brake is applied
Low output torque	Increase P1.27, 28 (torque limit)
The value of speed out of control level is too small	Confirm parameter value of P4.21
Low gain	Perform gain adjustment, or increase the value of speed out of control timeout (parameter p4.22)
Acceleration/deceleration is too acute	Increase the acceleration/deceleration time, or increase the value of speed out of control timeout (parameter p4.22)
The electronic gear ratio is set incorrectly	Confirm the set value for the relevant parameters of the electronic gears

(20) Homing timeout

【Display】



【Description of detected alarm】

The homing is not completed within the set time.

【Causes and Solutions】

Causes	Solutions
The homing signal is lost, resulting in the unable to complete the origin return	Repair homing signal sensor
Homing timeout (parameter P4.25) set value too small	Increase the setting value of the parameter P4.25, or set it to 0 to turn off the timeout check

10.1 SCH Series AC Permanent-Magnet Servo Motor

SCH series AC permanent-magnet servo motor can cooperate with relative servo motor drive devices to constitute a mutual coordinated system being widely applicable for many industries such as machine tools, textile, plastic machines, dyeing, printing, construction materials, radar, and guns.

SCH series AC permanent-magnet servo motor consists of stator, rotor, and high-precision feedback elements (such as photoelectric encoder and rotary transformer). It applies high-performance rare-earth permanent magnet material to build an air gap magnetic field and non-shell stator iron-core, whose temperature gradient is big and radiation efficiency is high, so that it has below advantages:

- Compact structure and high power density;
- Small rotor inertia and quick response;
- Rare-earth permanent magnetic material with superb high intrinsic coercivity; high demagnetization resistance capability;
- Remaining constant torque output for any speed within the range mostly;
- Small pulsation for low-speed torque; high accuracy balancing, working stably in high speed;
- Low noise and small vibration;
- Full sealed design;
- High performance-price ratio

10.2 Servo Motor Model Description

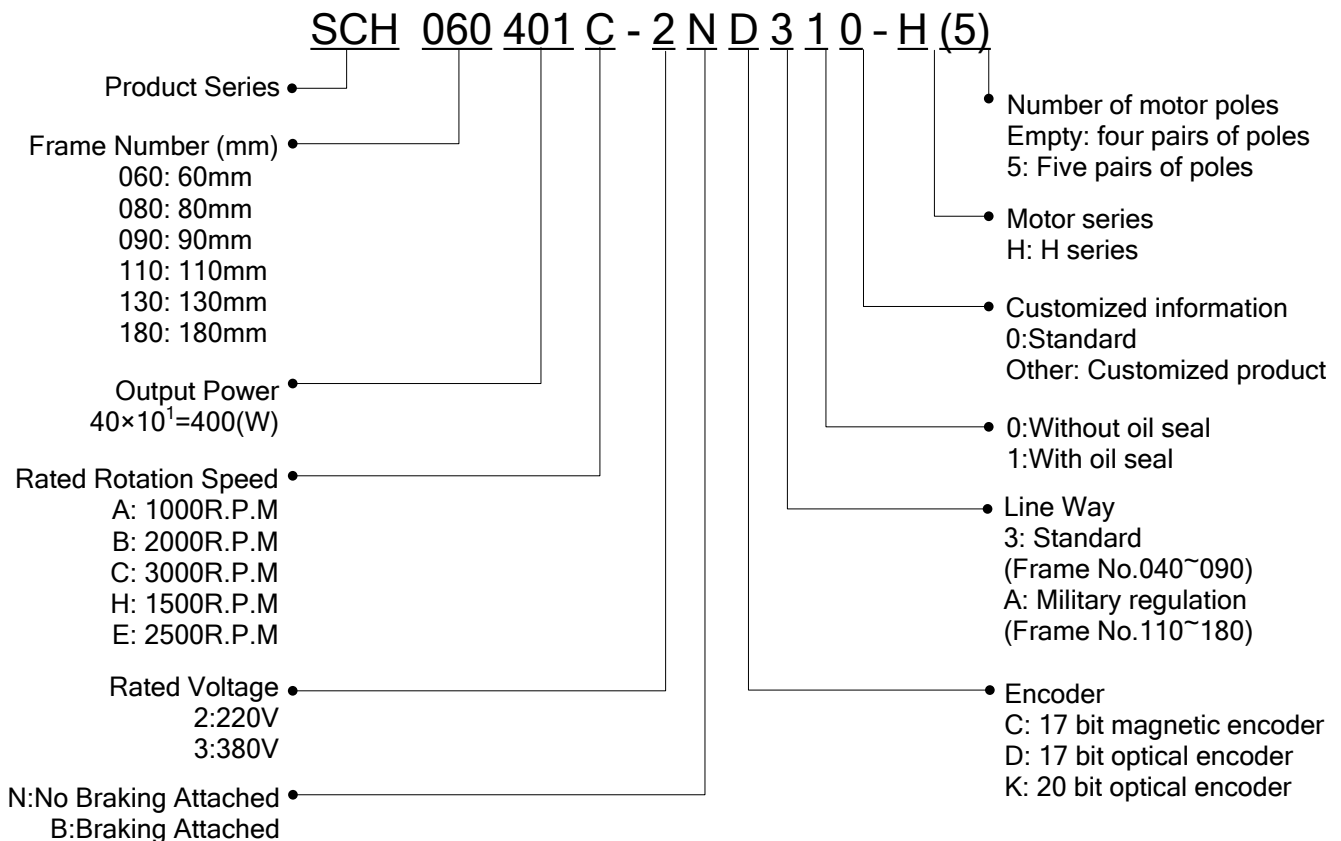

10.3 Servo Motor Specification

H series 220V

60 mm Series

Item		Servo Motor Model	
		SCH060201C	SCH060401C
Rated Output Power(W)		200	400
Applicable Servo Motor Driver		SDV3-2S0.4G	SDV3-2S0.4G
Rated Torque(N•m)		0.64	1.27
Rated Rotation Speed((R.P.M)		3000	3000
Rated Current(A)		1.8	2.6
Rotor Inertia (kg•m ² ×10 ⁻⁴)		0.264	0.407
Instant Max Torque(N•m)		1.91	3.81
Max Rotation Speed(R.P.M)		3600	3600
Weight(kg)		1.2	1.6
Insulation Level		F Class (155℃)	
Servo motor Ambient Temperature		-20℃~+40℃	
Permanent magnet brake	Brake Rated Voltage(V)	DC24±10%	
	Brake Static Friction Torque(N.m)	2	
	Brake Rated Power(W)	11	

80 mm Series

Item		Servo Motor Model		
		SCH080751C	SCH080731B	SCH080102E
Rated Output Power(W)		750	730	1000
Applicable Servo Motor Driver		SDV3-2S0.75G	SDV3-2S0.75G	SDV3-2S1.0G
Rated Torque(N•m)		2.39	3.5	4
Rated Rotation Speed((R.P.M)		3000	2000	2500
Rated Current(A)		3	3	4.4
Rotor Inertia (kg•m ² ×10 ⁻⁴)		1.82	2.63	2.97
Instant Max Torque(N•m)		7.1	10.5	12
Max Rotation Speed(R.P.M)		3600	2400	3000
Weight(kg)		2.9	3.9	4.1
Insulation Level		F Class (155℃)		
Servo motor Ambient Temperature		-20℃~+40℃		
Magnetic Brake	Brake Rated Voltage(V)	DC24±10%		
	Brake Static Friction Torque(N.m)	4		
	Brake Rated Power(W)	18		

H series 220V

110 mm Series

Item		Servo Motor Model			
		SCH110122C	SCH110152C	SCH110122B	SCH110182C
Rated Output Power(W)		1200	1500	1200	1800
Applicable Servo Motor Driver		SDV3-2S1.0G	SDV3-2S1.5G	SDV3-2S1.0G	SDV3-2S1.5G
Rated Torque(N•m)		4	5	6	6
Rated Rotation Speed((R.P.M)		3000	3000	2000	3000
Rated Current(A)		5	6	4.5	6
Rotor Inertia (kg•m ² ×10 ⁻⁴)		5.4	6.3	7.6	7.6
Instant Max Torque(N•m)		12	15	12	18
Max Rotation Speed(R.P.M)		3600	3600	2400	3600
Weight(kg)		6	6.8	7.9	7.9
Insulation Level		F Class (155°C)			
Servo motor Ambient Temperature		-20°C~+40°C			
Magnetic Brake	Brake Rated Voltage(V)	DC24±10%			
	Brake Static Friction Torque(N.m)	8			
	Brake Rated Power(W)	15			

130 mm Series

Item		Servo Motor Model				
		SCH130102 E	SCH130132 E	SCH130152 E	SCH130102 A	SCH130152 H
Rated Output Power(W)		1000	1300	1500	1000	1500
Applicable Servo Motor Driver		SDV3-2S1.0G	SDV3-2S1.0G	SDV3-2S1.5G	SDV3-2S1.0G	SDV3-2S1.5G
Rated Torque(N•m)		4	5	6	10	10
Rated Rotation Speed((R.P.M)		2500	2500	2500	1000	1500
Rated Current(A)		4	5	6	4.5	6
Rotor Inertia(kg•m ² ×10 ⁻⁴)		8.5	10.6	12.6	19.4	19.4
Instant Max Torque(N•m)		12	15	18	20	25
Max Rotation Speed(R.P.M)		3000	3000	3000	1200	1800
Weight(kg)		6.2	6.6	7.4	10.2	10.2
Insulation Level		F Class (155°C)				
Servo motor Ambient Temperature		-20°C~+40°C				
Magnetic Brake	Brake Rated Voltage(V)	DC24±10%				
	Brake Static Friction Torque(N.m)	16				
	Brake Rated Power(W)	25				

H series 380V

80mm series

Item		Servo Motor Model		
		SCH080751C	SCH080731B	SCH080102E
Rated Output Power(W)		750	730	1000
Applicable Servo Motor Driver		SDV3-4T0.75G	SDV3-4T0.75G	SDV3-4T1.0G
Rated Torque(N•m)		2.39	3.5	4
Rated Rotation Speed((R.P.M)		3000	2000	2500
Rated Current(A)		1.6	1.8	2.3
Rotor Inertia (kg•m ² ×10 ⁻⁴)		1.82	2.63	2.97
Instant Max Torque(N•m)		7.1	10.5	12
Max Rotation Speed(R.P.M)		3600	2400	3000
Weight(kg)		2.9	3.9	4.1
Insulation Level		F Class (155°C)		
Servo motor Ambient Temperature		-20°C~+40°C		
Magnetic Brake	Brake Rated Voltage(V)	DC24±10%		
	Brake Static Friction Torque(N.m)	4		
	Brake Rated Power(W)	18		

110mm series

Item		Servo Motor Model			
		SCH110122C	SCH110152C	SCH110122B	SCH110182C
Rated Output Power(W)		1200	1500	1200	1800
Applicable Servo Motor Driver		SDV3-4T1.0G	SDV3-4T1.5G	SDV3-4T1.0G	SDV3-4T1.5G
Rated Torque(N•m)		4	5	6	6
Rated Rotation Speed((R.P.M)		3000	3000	2000	3000
Rated Current(A)		3.0	4.5	3.0	4.5
Rotor Inertia (kg•m ² ×10 ⁻⁴)		5.4	6.3	7.6	7.6
Instant Max Torque(N•m)		12	15	12	18
Max Rotation Speed(R.P.M)		3600	3600	2400	3600
Weight(kg)		6	6.8	7.9	7.9
Insulation Level		F Class (155°C)			
Servo motor Ambient Temperature		-20°C~+40°C			
Magnetic Brake	Brake Rated Voltage(V)	DC24±10%			
	Brake Static Friction Torque(N.m)	8			
	Brake Rated Power(W)	15			

H series 380V

130mm series

Item	Servo Motor Model			
	SCH130102E	SCH130132E	SCH130152E	SCH130202E
Rated Output Power(W)	1000	1300	1500	2000
Applicable Servo Motor Driver	SDV3-4T1.0G	SDV3-4T1.0G	SDV3-4T1.5G	SDV3-4T2.0G
Rated Torque(N•m)	4	5	6	7.7
Rated Rotation Speed((R.P.M)	2500	2500	2500	2500
Rated Current(A)	2.6	3.0	4.0	4.7
Rotor Inertia (kg•m ² ×10 ⁻⁴)	8.5	10.6	12.6	15.3
Instant Max Torque(N•m)	12	15	18	22
Max Rotation Speed(R.P.M)	3000	3000	3000	3000
Weight(kg)	7.7	8.2	8.9	10.0
Insulation Level	F Class (155°C)			
Servo motor Ambient Temperature	-20°C~+40°C			
Magnetic Brake	Brake Rated Voltage(V)	DC24±10%		
	Brake Static Friction Torque(N.m)	8		
	Brake Rated Power(W)	15		

Item	Servo Motor Model			
	SCH130102A	SCH130152H	SCH130262E	SCH130232H
Rated Output Power(W)	1000	1500	2600	2300
Applicable Servo Motor Driver	SDV3-4T1.0G	SDV3-4T1.5G	SDV3-4T2.0G	SDV3-4T2.0G
Rated Torque(N•m)	10	10	10	15
Rated Rotation Speed((R.P.M)	1000	1500	2500	1500
Rated Current(A)	2.5	3.5	6.0	5.0
Rotor Inertia (kg•m ² ×10 ⁻⁴)	19.4	19.4	19.4	27.7
Instant Max Torque(N•m)	20	25	25	30
Max Rotation Speed(R.P.M)	1200	1800	3000	1800
Weight(kg)	10.1	12.1	9.1	12.6
Insulation Level	F Class (155°C)			
Servo motor Ambient Temperature	-20°C~+40°C			
Magnetic Brake	Brake Rated Voltage(V)	DC24±10%		
	Brake Static Friction Torque(N.m)	16		
	Brake Rated Power(W)	25		

10.4. Servo Motor External Dimension

60mm series

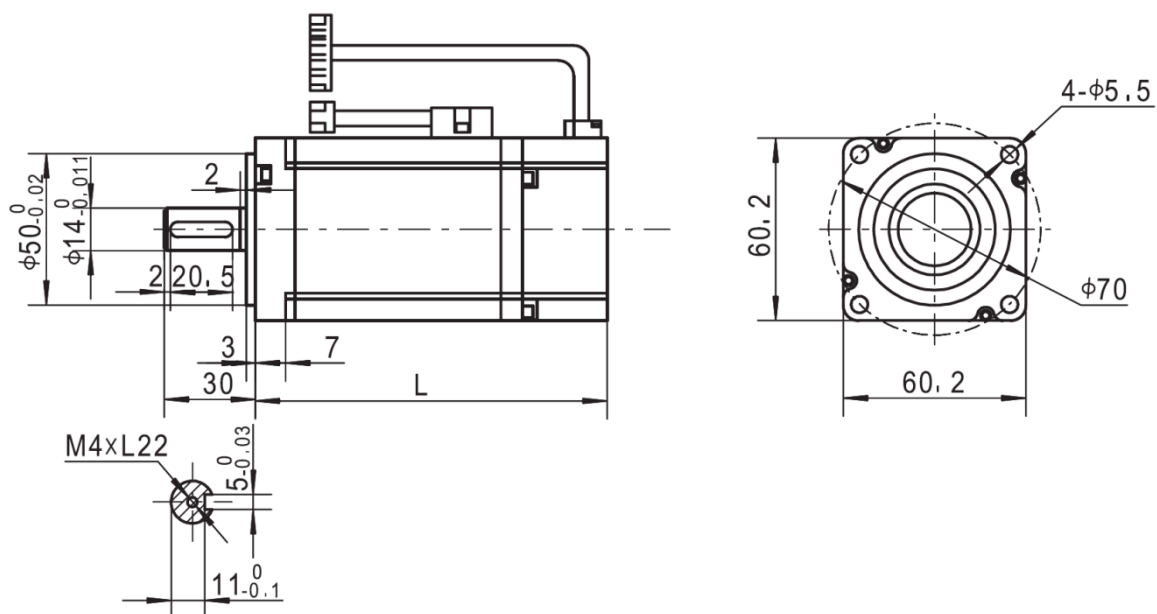

220V

Model	SCH060201C	SCH060401C
L(Without Brake)	109	133
L(With Brake)	157	181

80mm series

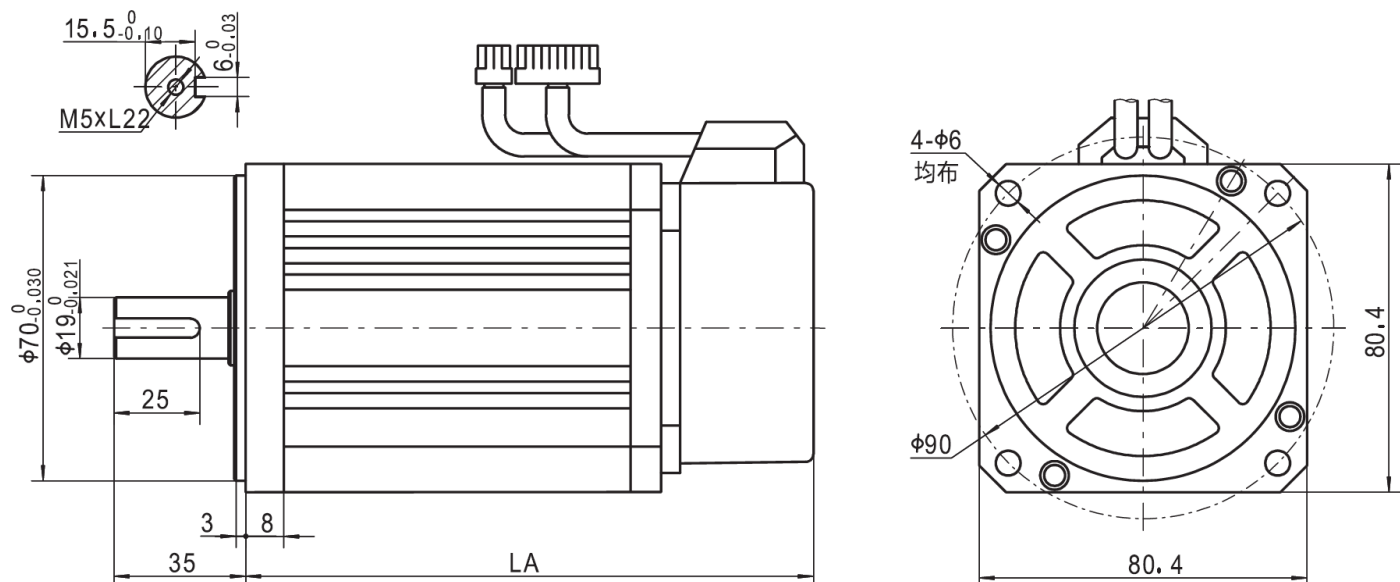

220V/380V

Model	SCH080751C	SCH080731B	SCH080102E
L(Without Brake)	151	179	191
L(With Brake)	193	221	233

110mm series

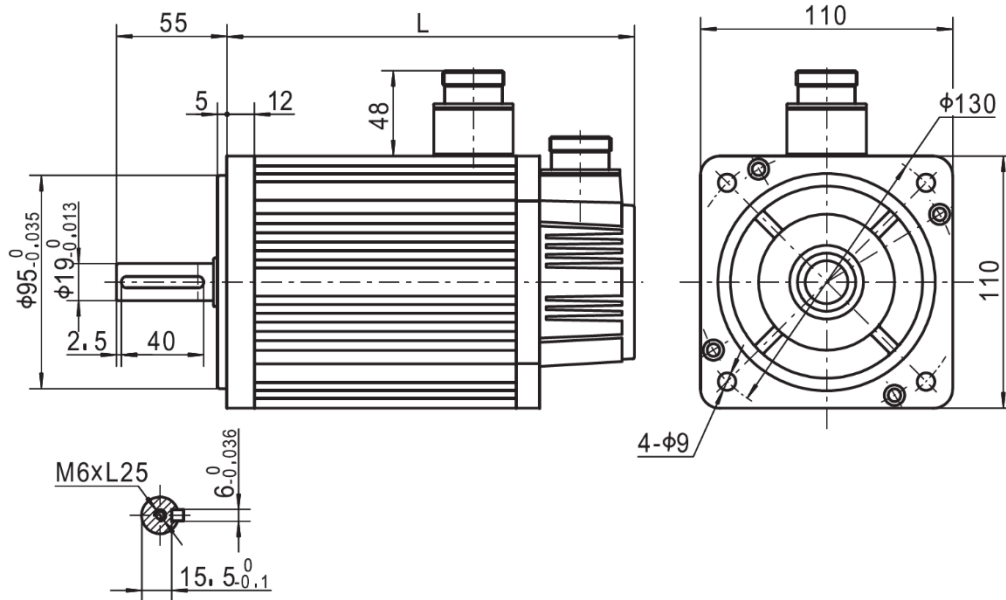

220V/380V

Model	SCH110122C	SCH110152C	SCH110122B	SCH110182C
L(Without Brake)	189	204	219	219
L(With Brake)	254	269	284	284

130mm series

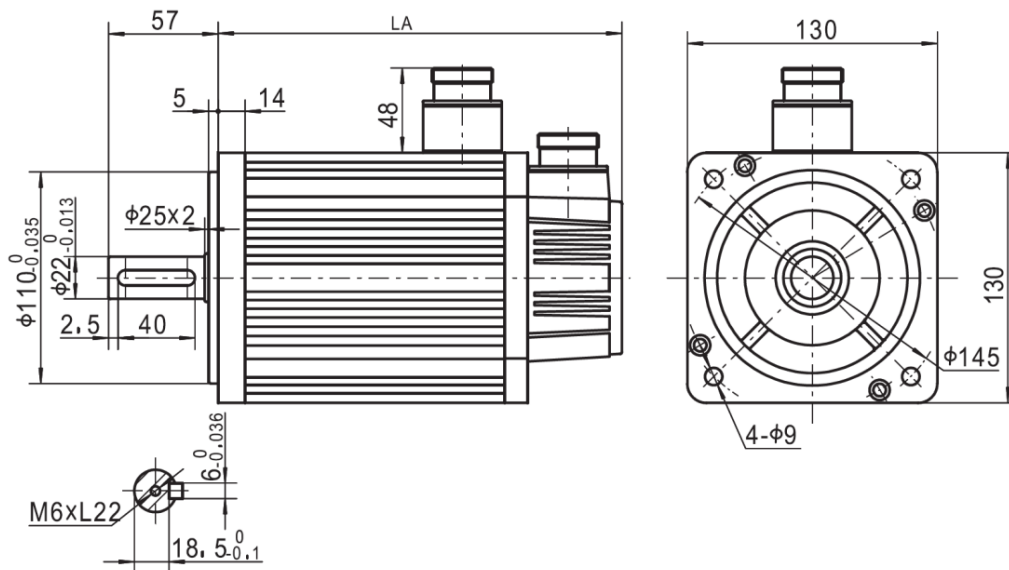

380V

Model	SCH130202E	SCH130262E	SCH130232H
L(Without Brake)	192	209	241
L(With Brake)	252	272	304

220V/380V

Model	SCH130102E	SCH130132E	SCH130152E	SCH130102A	SCH130152H
L(Without Brake)	166	171	179	213	213
L(With Brake)	226	231	239	276	276

10.5 Delivery and Storage

Servo motors shall be kept in a dry, dust free place, and be avoided any impacts.

10.6 Wiring

Please refer to the section 2.5 in 2nd chapter about the wiring method.

※ Basic principle of servo motor wiring

- The cables and plugs shall be matching with the sockets, and their voltage and current values shall be qualified.
- The cables shall be long enough, and can't be winded, tied up, or stretched tightly.
- The system shall be earthed reliably.
- A plug shall be aligned with the key seat of the socket.
- A plug shall be fastened correctly so that the servo motor is guaranteed to be connected reliably and sealed well.

※ Power cable

- Never connect 3 phase AC power to the servo motor directly; otherwise the servo motor may be broken.
- Check the phase sequence of the servo motor for wiring is correct.
- The servo motor can't work with unmatching servo motor drive.

※ Brake wire

Brake wire uses the same socket with the power. Brake is working under the magnetic circuit closure principle. Feed a $24\text{VDC}\pm 10\%$, the brake is opening. The voltage shall be feed within the error tolerance range; otherwise the reliable operation may be affected. When the servo motor is running, the brake is energized and opened; when the brake is de-energized, the rotor and stator will be absorbed to each other and hold the servo motor shaft together to let it be immovable.

Note: Servo motor drive internal power is not applied to the motor brake power

- Before using the servo motor, please check
 - ①There is no friction between the rotor and the stator of the servo motor, so that it can rotate smoothly.
 - ②The servo motor is mounted firmly, and the coaxiality is good.
 - ③The servo motor is earthed correctly.
 - ④All accessories (such as brake) applied are working normally.
 - ⑤The speed doesn't exceed the maximal rotating speed of the servo motor, which is maximal rotating speed allowable in a short period.

11.1 About Optional Parts

In some applications, a servo motor is used as the generator. In that case, its regenerative energy will charge for the power capacitor of servo motor drive and too much voltage may cause servo motor drive damaged, therefore, that regenerative energy shall be released properly. Servo motor drive produced by our company will release the regenerative brake energy by a power resistor.

11.2 Standard Configuration for Drive Braking parts

220V

Drive model	Min allowable resistance(Ω)
SDV3-2S0.4G	45
SDV3-2S0.75G	40
SDV3-2S1.0G	30
SDV3-2S1.5G	30

380V

Drive model	Min allowable resistance(Ω)
SDV3-4T0.75G	80
SDV3-4T1.0G	80
SDV3-4T1.5G	50
SDV3-4T2.0G	50

11.3 Optional Regenerative Or Braking Parts

How magnitude is the resistor applied depends on the load torque inertia, rotating speed before braking, the time within which the braking can be finished, and maximal withstand current for brake circuit. To facilitate the analysis, the braking process can be divided into two phases. We will take a SDV3-2S0.75G as the example to make a introduction, with the normal bus voltage of 310V。

•Phase 1:

Firstly we consider the situation that, under the condition of non-friction resistance torque and non regenerative resistor, the dynamic energy of the rotor will all charge into a capacitor. Then, the voltage applied on the capacitor can be calculated in following formula。

$$0.5 \times J \times n^2 = 0.5 \times C \times (V^2 - 310^2)$$

J:The sum of all inertias of the rotors connected on same shaft, unit: kg·m²;

n:The rotating speed of the rotor before braking, unit: radian/s;

V: Under non-friction resistance torque and non-regenerative resistor condition, the voltage that has been charged into the capacitor;

C: Capacitance inside servo motor drive;

•Phase 2:

The electric energy that has been charged into is turning into thermal energy. The voltage threshold value to activate the brake of servo motor drive is 370V, the voltage threshold value to inactivate the brake is 360V, so the voltage value for whole braking process is the average value of these two, which is 365V.

$$0.5 \times C \times (V^2 - 360^2) = \frac{365^2}{R} \times t$$

R: Resistance value of regenerative resistor;

t: Braking time;

When the value of the regenerative resistor is confirmed, you shall confirm its power now. $P=370^2/R$. Since the braking status won't last in a long term, the actual power can just take a value a little smaller than P in accordance with the braking duty ratio. For example, if the braking duty ratio is 20%, the resistor power could be 0.2P. Feed more vacancy, take $0.2 \times P \times 150\% = 0.3P$.

In order to simplifying the treatment, in above analysis, it's believed that the dynamic energy of the rotor is finally transferred into the thermal energy consumed by the resistor and the electric energy left in the capacitor, and assumed that the braking operation is completed During once process. Actually certain part of the energy of the rotor will be consumed for other reasons, such as load friction resistance force and driving damping. Besides, after turning on the brake, the voltage may be within 360~370V. If the voltage drops to be lower than 360V, the brake will be shut down. So it may take several times to start the brake, and the braking process may not be accomplished for just once try. Customers can make some adjustments based on actual situations.

⚠ CAUTION

- The resistance value of regenerative resistor shall attain the requirement to maximal current limit. After parallel connection, the current=bus voltage during braking/R, so the value must be guaranteed not to be exceed the maximal brake current limit.

- Innovate for more | win forever
- Industry intelligence | Energy saving | Green power



Savch wechat
Service Number

Quanzhou Factory

Address: 3# Zixin Road, Jiangnan Hi-Tech Industrial Park,
Quanzhou, Fujian, China
Tel: 0595-24678267 Fax: 0595-24678203

Service Network

Website: www.savch.net

Qualification

Received ISO9001 and CE recognition

All rights reserved. Subject to change without further notice.

Sales service contact address